



DSU II

Digital Telephone System

System Manual

This publication is applicable to the following common equipment: J0408, J0816, and J1632 with software revision 2A and later

Supports *Impact*, *Impression*, *DigiTech*, and
Scout Telephones

COMDIAL®

System Hardware And Software Instructions

DSU II Digital Telephone System

This publication is applicable to the following equipment:
J0408, with software revision 2A and later
J0816, with software revision 2A and later
J1632, with software revision 2A and later

Supports *Impact*, *Impression*, *DigiTech*, and *Scout*
Telephones



*Comdial's Quality Management System Is
Certified To The ISO 9001 Standard.*

Attention

Comdial[®] makes every effort to design the features in our communications systems to be fully interactive. Under certain conditions, some features may be incompatible with each other and will not work simultaneously. Comdial assumes no responsibility for problems caused by incompatible features.

The possible combinations of accessories and features are far too numerous for us to document in this manual. Furthermore, Comdial Corporation cannot guarantee that features will operate as described in this publication when they are combined with other features.

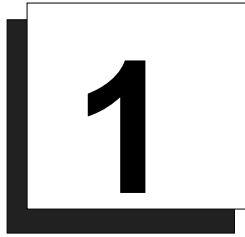

Introducing The DSU II Digital Telephone System

<u>Section</u>	<u>Title</u>	<u>Page</u>
1.1	Using This Manual	1-2
1.2	Using Related Publications	1-3
1.2.1	Locating User Information	1-3
1.3	Detailing The Accessory Information	1-5
1.3.1	Analog Terminal Interface	1-5
1.3.2	Headset Operation	1-5
1.3.3	Battery Back Up	1-6
1.3.4	DSS/BLF Console	1-6
1.3.5	Caller ID	1-6
1.3.6	Tracker.....	1-6
1.3.7	DVA	1-6
1.3.8	DIU	1-6
1.4	Summarizing The Hardware	1-7
1.5	Describing The Common Equipment	1-8
1.6	Describing The Stations	1-10
1.6.1	DigiTech Telephones	1-10
1.6.2	<i>Impact</i> Telephones	1-12
1.6.3	Impression Telephones	1-14
1.6.4	Scout 900MX Telephone	1-16
1.6.4	Station Controls and Indicators	1-18
1.7	Understanding The General Specifications	1-21
1.7.1	Feature Codes	1-23
1.7.2	System Ringing Patterns.....	1-26
1.8	Seeking Repair Assistance	1-27

1.1 Using This Manual

This publication contains a technical discussion of the digital telephone system; it provides step-by-step instructions for installation and programming. If you are unfamiliar with the equipment, read this manual at least once before you attempt to install and program the system. The five chapters in this manual are as follows.

- Chapter One, *Introducing The DSU II Digital Telephone System*, is a general description of the digital telephone system, the supporting documentation, and the equipment hardware.
- Chapter Two, *Installing The DSU II Digital Telephone System*, contains installation instructions and connection details.
- Chapter Three, *Programming The DSU II Digital Telephone System*, gives you instructions for setting the operating parameters of the system.
- Chapter Four, *Recording The Programming Information*, contains charts for recording programming decisions.
- Appendix A, *Describing The System Features*, details features the digital telephone system offers.

1.2 Using Related Publications

The following publications contain information applicable to the digital telephone system. Should you need copies of these publications, contact your Comdial inside sales representative.

Comdial
Inside Sales Department
P.O. Box 7266
Charlottesville VA 22906
Call: 1-800-347-1432

1.2.1 Locating User Information

Working With Electrostatically Sensitive Components

IMI 01-005 *Handling of Electrostatically Sensitive Components*

Operating With DigiTech Telephones and Consoles

These user guides are for DigiTech telephones with product codes 7700S, 7714X, and 7714S, with revision A through H, and console DD32X.

- GCA70-183 DigiTech Multiline Telephone System User's Guide
- GCA70-182 DigiTech Attendant's Guide
- GCA70-184 DigiTech Station User's Guide
- GCA70-232 DigiTech Single-Line Proprietary Telephone User's Guide
- GCA70-187 DigiTech DSS/BLF Console User's Guide

These user guides are for DigiTech telephones with product codes 7700S, 7714X, and 7714S, with revision I and later, and console DD32X.

- GCA70-220 DigiTech LCD Speakerphone System User's Guide
- GCA70-221 DigiTech Multiline Telephone System User's Guide
- GCA70-228 DigiTech Attendant's Supplement
- GCA70-232 DigiTech Single-Line Proprietary Telephone User's Guide
- GCA70-187 DigiTech DSS/BLF Console User's Guide

Operating With Impact Telephones and Consoles

These user guides are for telephones with product codes 8024S, 8124S, 8012S, 8112N, 8101N, and console IB64X.

- GCA70–245 Impact LCD Speakerphone System User’s Guide
- GCA70–244 Impact Multiline Telephone System User’s Guide
- GCA70–247 Impact Attendant’s Supplement
- GCA70–248 Impact Station User’s Guide
- GCA70–246 Impact Single-Line Proprietary Telephone User’s Guide
- GCA70–256 Impact DSS/BLF Console User’s Guide

Operating With Impression Telephones

These user guides are for telephones with product codes 2022S, 2122S, 2122X, and 2101N.

- GCA70–328 Impression LCD Speakerphone System User’s Guide
- GCA70–329 Impression non-LCD Speakerphone And Monitor Telephone System User’s Guide
- GCA70–330 Impression Single Line Proprietary Telephone User’s Guide
- GCA70–332 Impression LCD Speakerphone Station User’s Guide
- GCA70–333 Impression non-LCD Speakerphone And Monitor Telephone Station User’s Guide

Operating With Industry-Standard Telephones Through The ATI-D

- GCA70–239 User’s Guide For The Industry-Standard Telephone
- IMI89–037 Installation Instructions For The Analog Terminal Interface (ATI-D).

1.3 Detailing The Accessory Information

The digital telephone system is capable of supporting several accessory software and hardware devices. You can add voice mail, industry standard telephones, and headset capabilities to your digital telephone system.

1.3.1 Analog Terminal Interface

By employing the Analog Terminal Interface device (ATI-D), the digital telephone system can support the operation of the following accessories:

- ExecuMail and Versatile Voice Processing, systems
- Industry-standard telephones and telephone devices.

For more information on the ATI-D, see section 2.19.2, *Installing The Analog Terminal Interface*.

1.3.2 Headset Operation

The Comdial DigiTech speakerphones with product codes of 7700S, revision H and earlier, include a built-in headset port. Speakerphones with a revision of I and later and *Impact* LCD speakerphones with product code 8024S provide an auxiliary jack for headset interface. The *Impression* telephone provides headset capability through its handset jack.

Contact your Comdial Inside Sales Representative for a list of compatible headset manufacturers.

NOTE: The system delivers subdued off-hook voice announce (SOHVA) messages to the headset port. Because a telephone headset exhibits a “coupling” effect between the ear piece and the microphone, it may allow the outside party to hear the SOHVA message.

1.3.3 Battery Back Up

You can install an optional battery backup that provides power to the system in the event of a power failure. For more information, see section 2.18.1, *Installing The Battery Backup*.

1.3.4 DSS/BLF Console

You can add a separate DSS/BLF console to provide additional DSS/BLF buttons to a particular station (such as an attendant). These additional DSS/BLF buttons work just like the DSS/BLF buttons on the telephone. For more information, see section 2.6, *Installing The DSS/BLF Console*.

1.3.5 Caller ID

Using the Caller Identification Interface (product code CID08), the digital telephone system provides caller ID information as part of the SMDR printout and as ASCII data input for use with personal-computer-based application programs.

1.3.6 Tracker

With Tracker you can send messages to Tracker Pagers assigned to a station extension number. When the pager is activated the user reads the message on the pager's LCD display. The system delivers alpha/numeric or numeric-only messages depending on the Tracker Model being used.

1.3.7 DVA

Digital voice announcing uses a hardware peripheral device (product code DVA01) connected to a digital station port to play recorded messages during an in-progress call. The DVA stores the messages in its memory for recall when needed.

1.3.8 DIU

The Data Interface Unit (DIU) is a device connected to a digital station port of a DSU. The DIU provides connections for a digital multiline telephone and another device such as a industry standard telephone (IST), FAX, or modem. The DIU switches the voice path from the DSU to either the digital telephone or the IST by pressing a button on the digital telephone.

1.4 Summarizing The Hardware

The digital telephone system consists of an electronic Digital Service Unit (DSU)—usually referred to as “common equipment”—optional expansion modules to extend station and line capacities, dedicated digital electronic key telephones, and interconnecting wiring consisting of small, 2- or 4-conductor, twisted-pair cable. The digital telephone system supports all Comdial proprietary digital telephone models.

The station and line capacity of the base unit and optional expansion modules are detailed in the following chart.

Model Number	CO/PBX Capacity	Station Capacity
J0408	4	8
J0816	8	16
J1632	16	32
JM408	4	8
JM008	0	8 industry-standard telephones

1.5 Describing The Common Equipment

The common equipment base unit for the DSU II digital telephone system is a fully electronic device. It is essentially a special purpose computer system acting as a communications controller between central office (CO), private branch exchange (PBX), or CENTREX supplied lines and the proprietary digital telephone stations. The software design of the common equipment provides complete system support and great flexibility of operation.

All DSU II systems have analog, loop-start line interfaces to the public switched network. Special integrated circuits (COder/DECOder or CODEC chips) in the line circuits translate analog voice information to and from the digital domain. Internally, the system is fully digital and has Pulse Code Modulation (PCM) highways that are time-division multiplexed into PCM channels. Each digital station has two B-channels available for voice and/or data and one D-channel available for telephone control. This arrangement is known as 2B+D. The system maintains communication with the stations with digital loop transceiver circuits that are under system software control. A time switch integrated circuit, also under system software control, routes calls, creates conferences, and set padding levels as required.

The common equipment consists of a base unit, which provides complete feature support, and optional expansion modules for additional lines and stations. It is contained in a contemporary metal housing designed to be inconspicuous in a modern office environment. It is engineered to be wall or rack mounted.

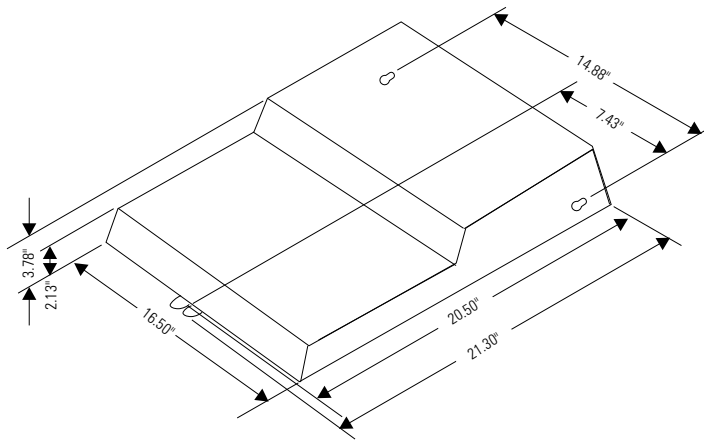

4-Line, 8-Station Base Unit

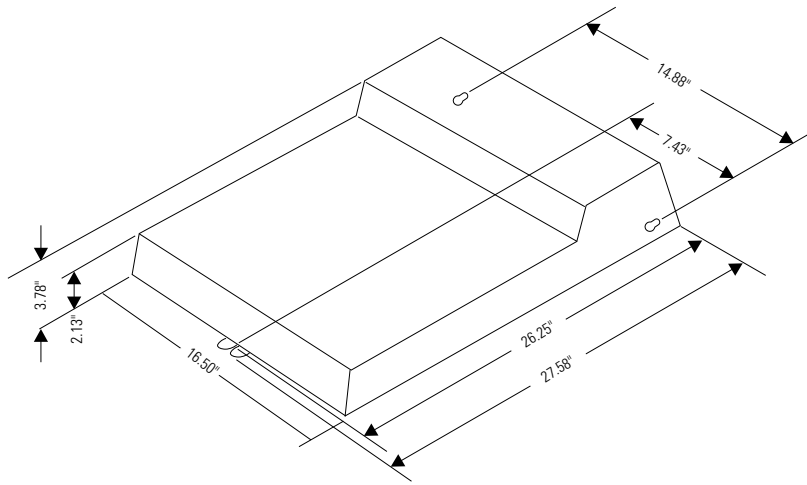

8-Line, 16-Station Base Unit

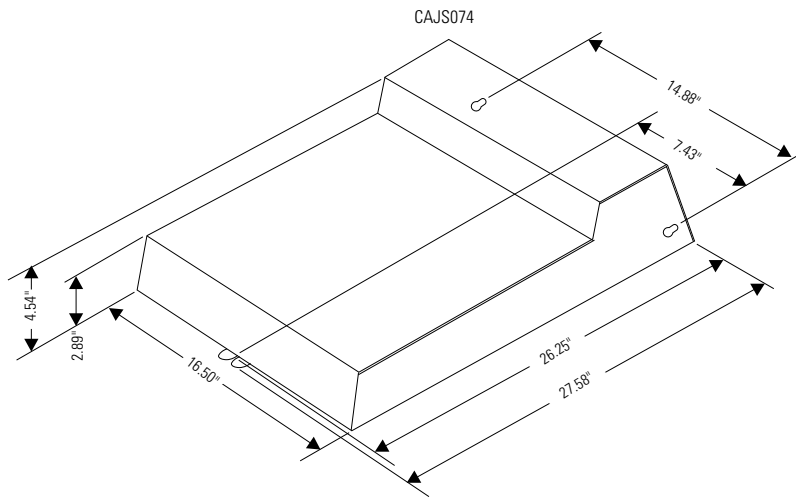

16-Line, 32-Station Base Unit

Detailing The Common Equipment Dimensions

1.6 Describing The Stations

The digital telephones used with the DSU II digital telephone system are electronic, microprocessor-controlled, devices. They allow not only multiline pickup but also single button access to features available from the serving CO, PBX, CENTREX, or common equipment. The digital telephones are available in several different styles with several models available in each style. The following list details the available telephones.

1.6.1 DigiTech Telephones

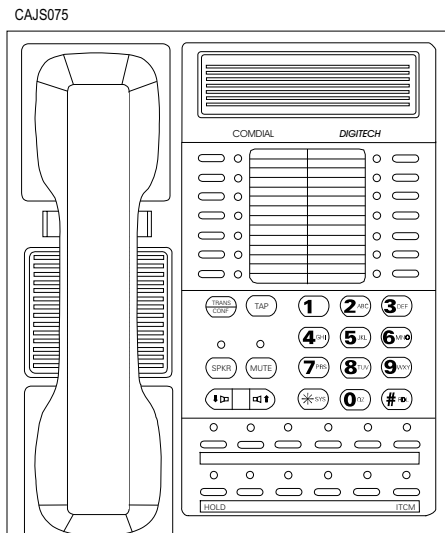

7714X Monitor Telephone
7714S Speaker Telephone

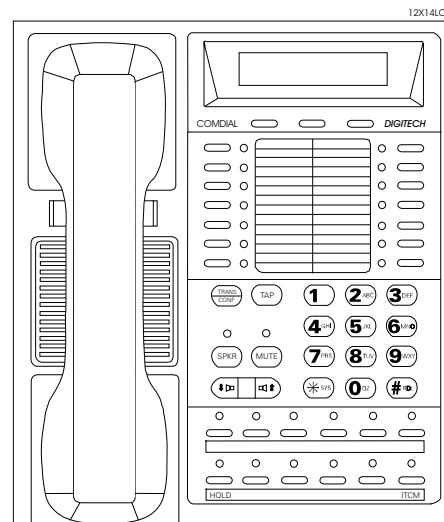

7700S LCD Speakerphone

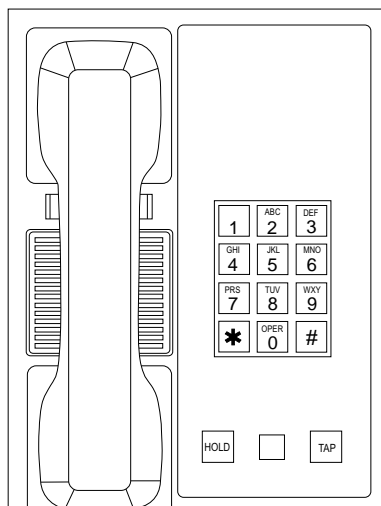

7701X Single Line Proprietary Telephone

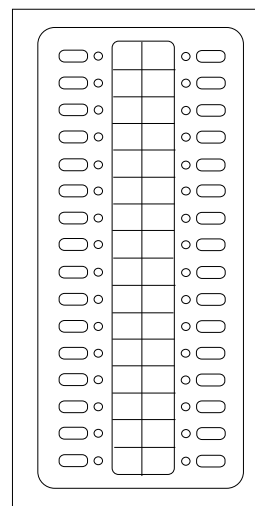

DD32X DSS/BLF Console

Viewing The DigiTech Telephone Images

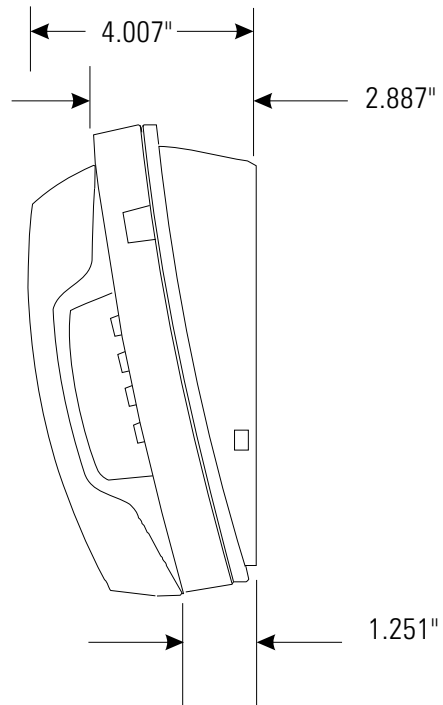
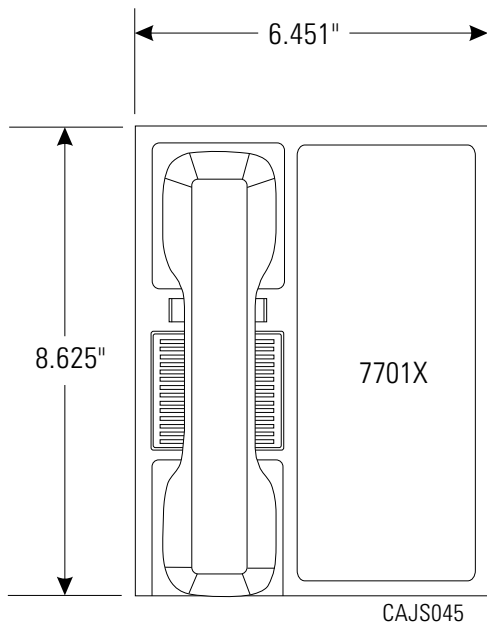
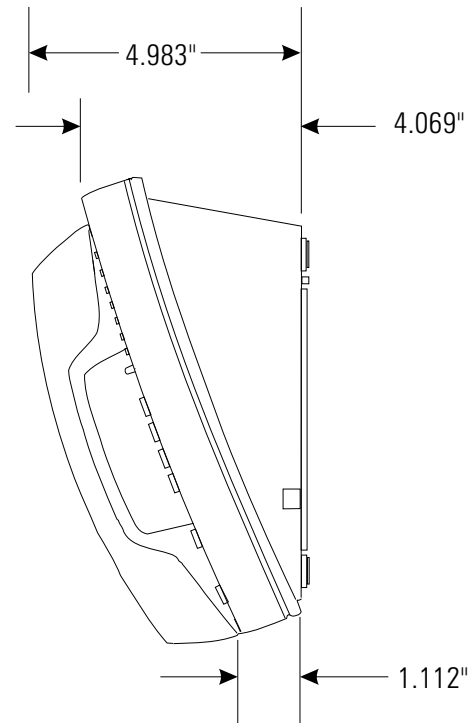
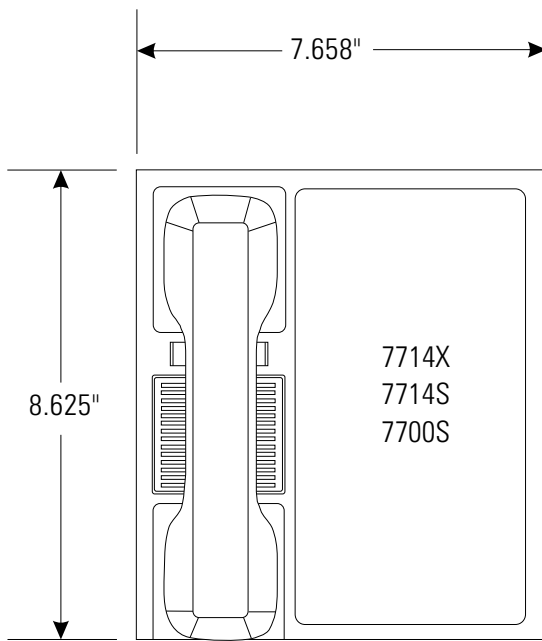

Detailing The DigiTech Dimensions

1.6.2 Impact Telephones

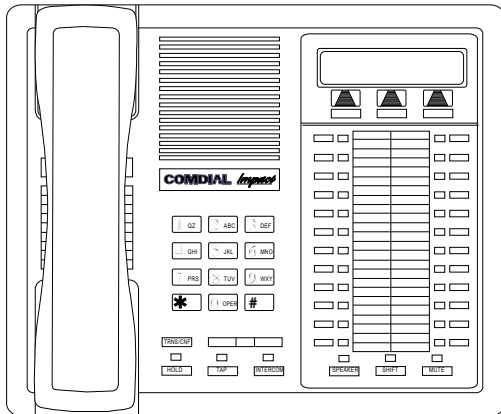

8024S LCD Speakerphone

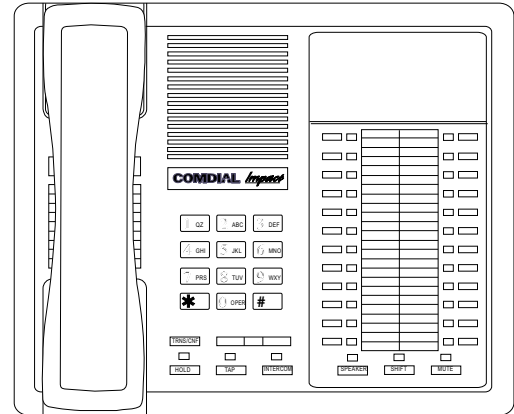

8124S Speakerphone

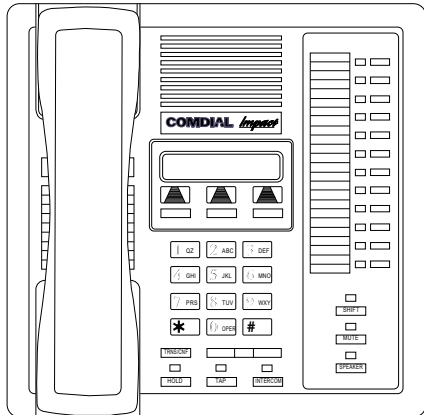

8012S LCD Speakerphone

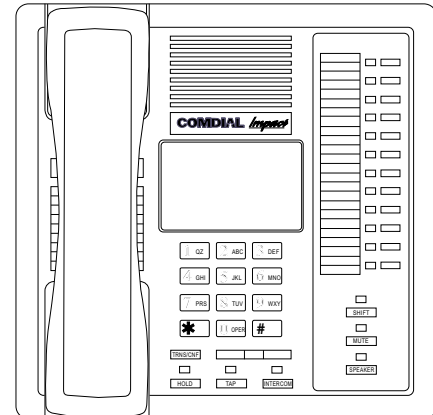

8112S Speakerphone

CAJS076

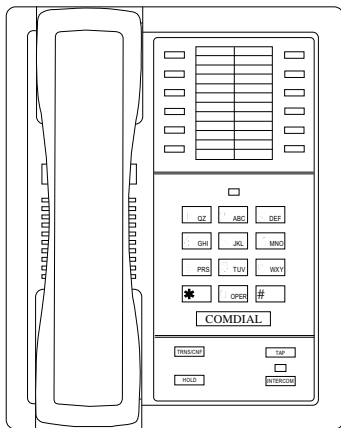

8112N Non-Monitor

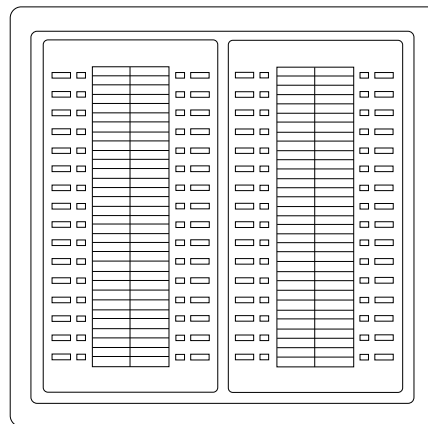

IB64X DSS/BLF Console

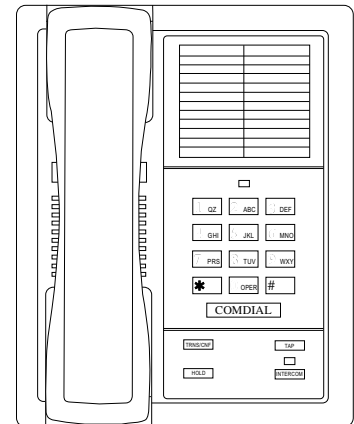

8101N
Single Line Proprietary Telephone

Viewing The Impact Telephone Images

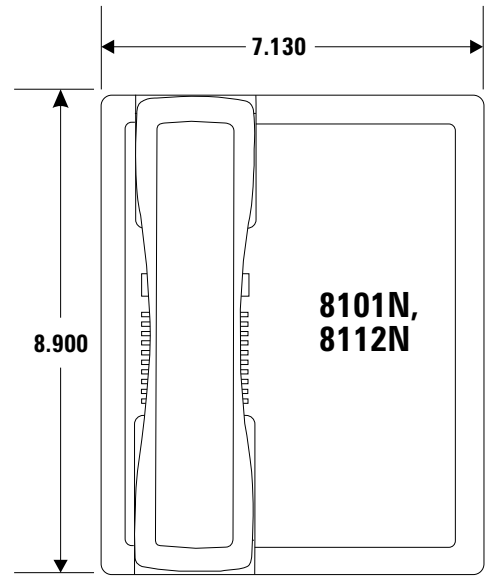
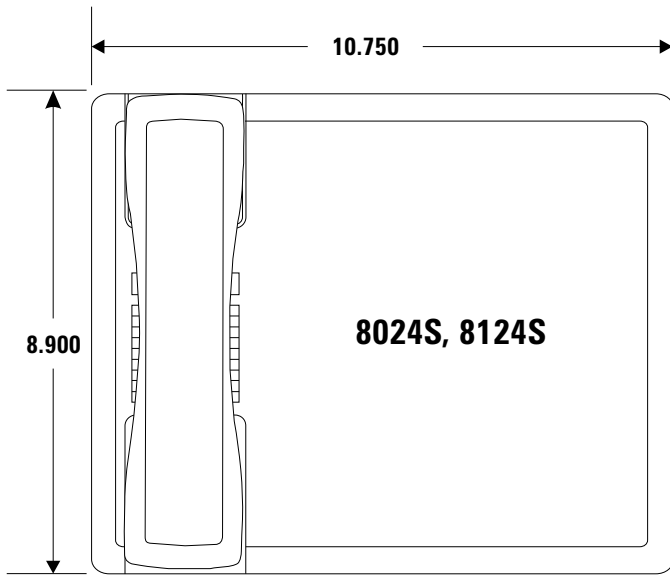

CAJS077

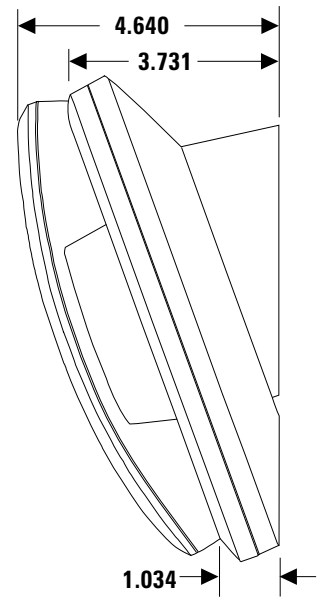
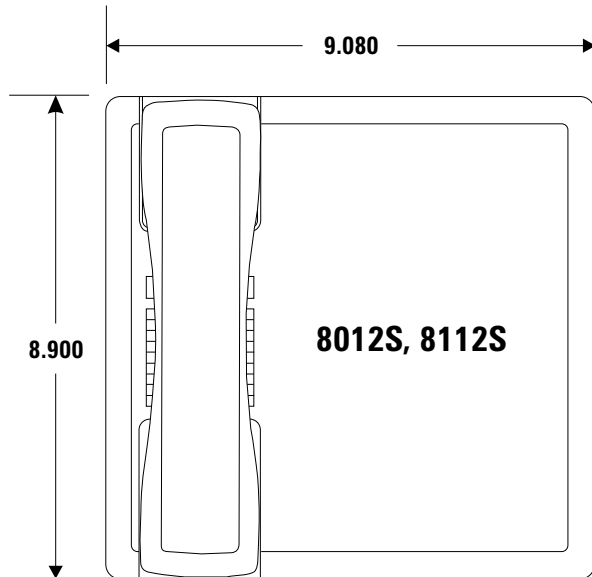

Detailing The Impact Dimensions

1.6.3 Impression Telephones

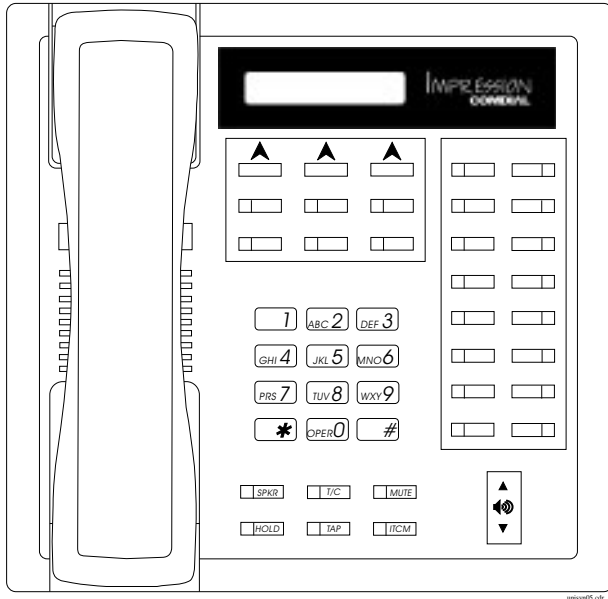

2022S (22-Line LCD Speakerphone)

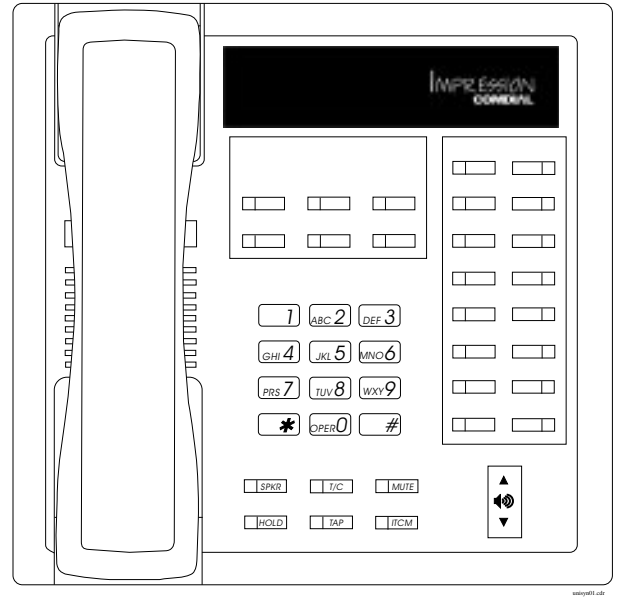

2122S (22-Line Speakerphone)
2122X (22-Line Monitor Telephone)

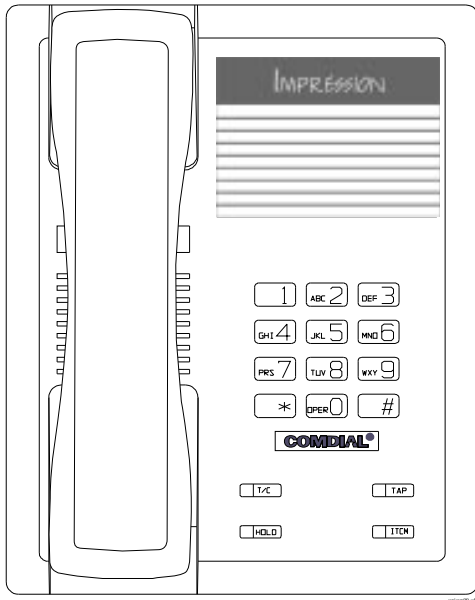

2101N (Single Line Proprietary Telephone)

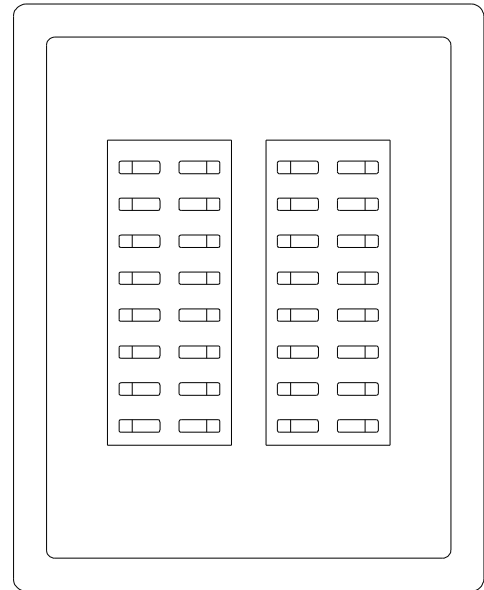

DU32X (32-Button DSS/BLF Console)

unisys11.cdr

Viewing The Impression Telephone Images

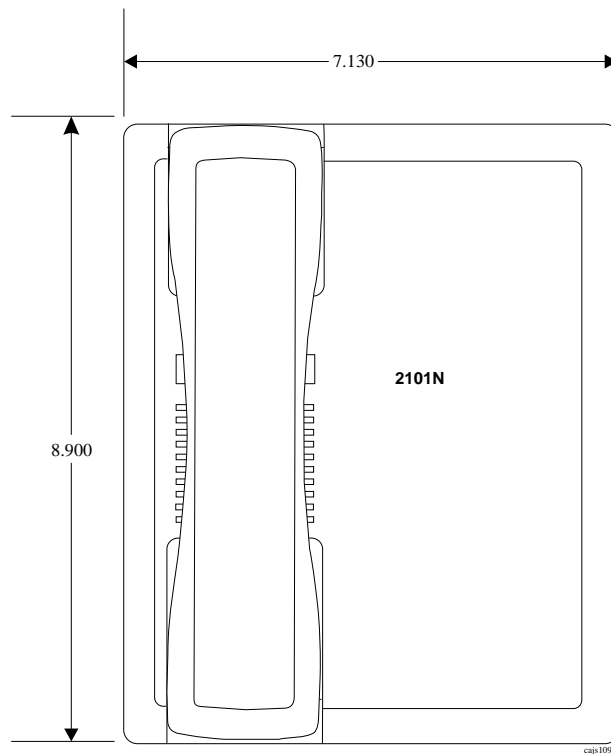
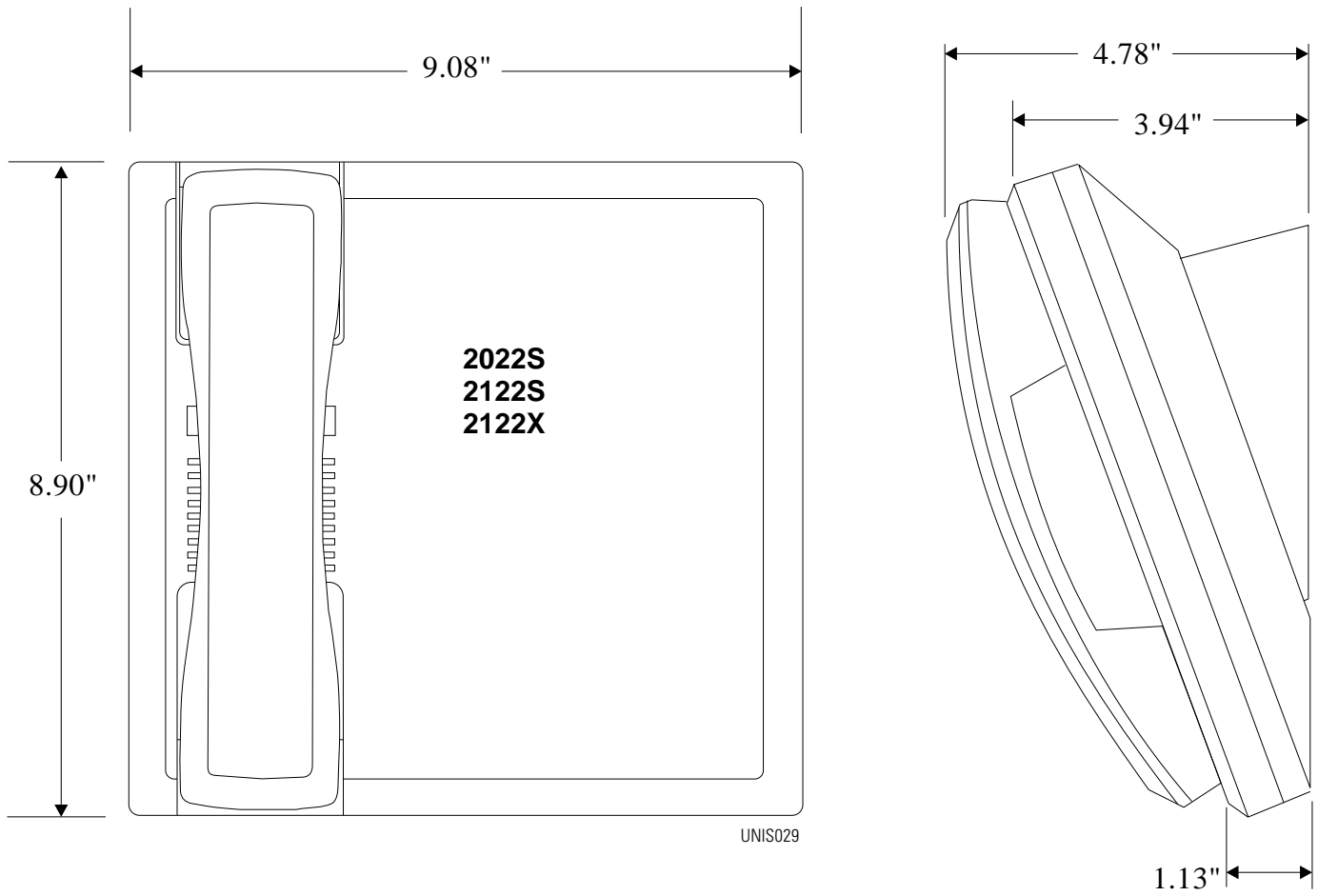

Detailing The Impression Telephone Dimensions

1.6.4 Scout 900MX Telephone

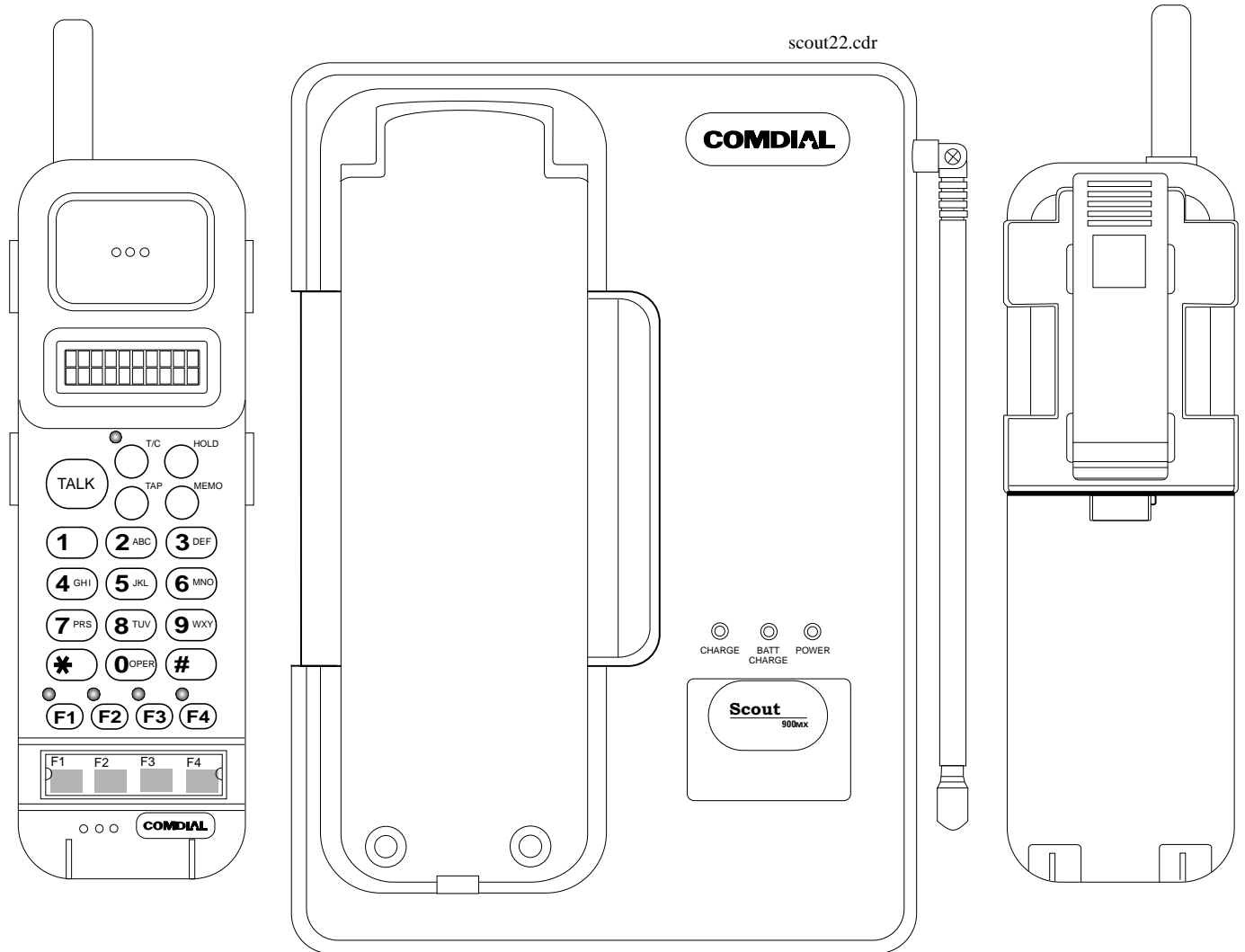

Viewing The Scout 900MX Telephone

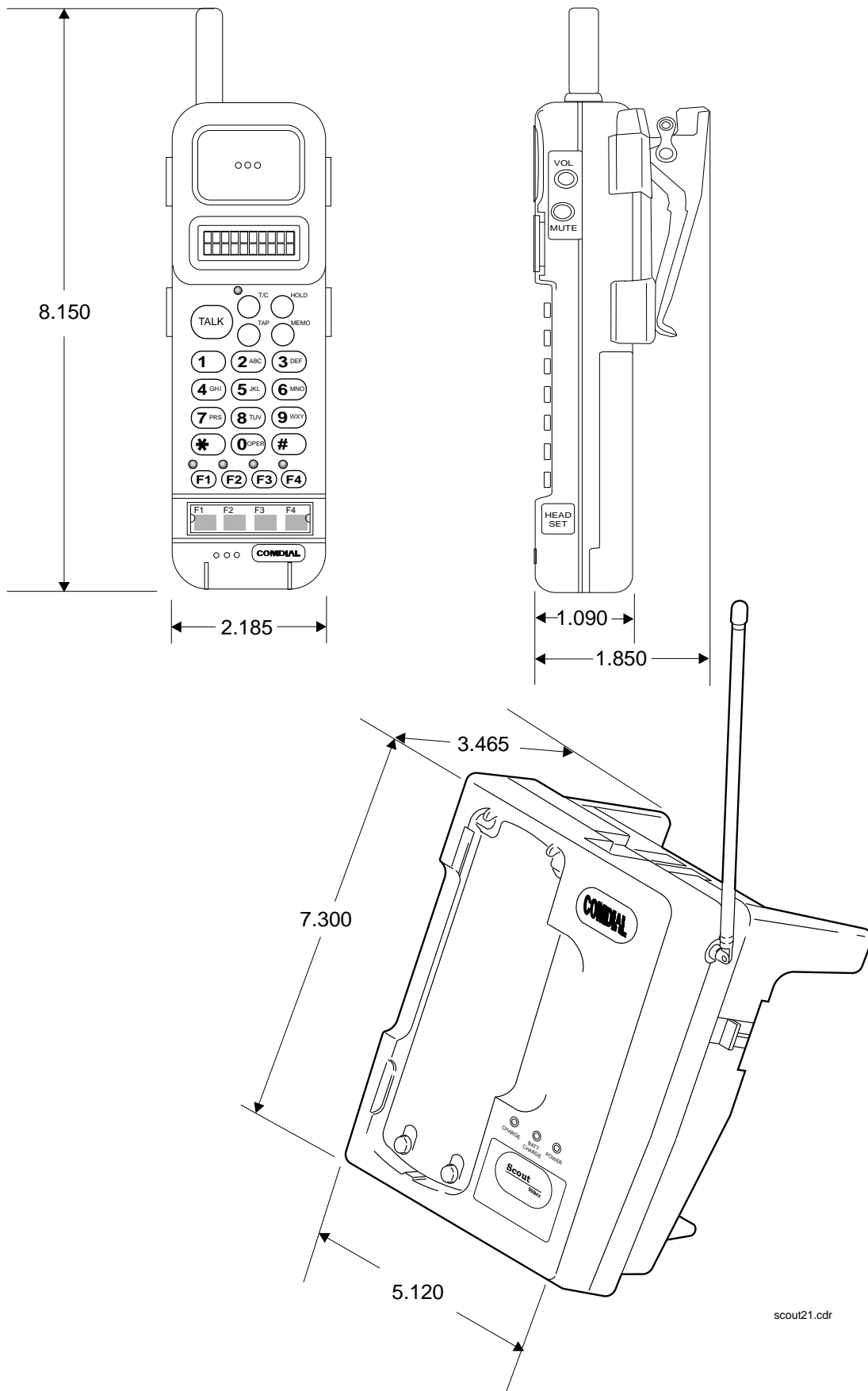

Detailing the Scout 900MX Dimensions

1.6.5 Station Controls And Indicators

Ringer Volume Control

Each station has a ringer volume control. Adjust the ringer volume of each station to suit your needs.

Telephone Model	Control Location
7114S, 7114X, 8024S, 8124S, 8012S, 8112S 2022S, 2122S, 2122X	Rocker switch located on front face plate. Adjust while ringing to set volume.
7701X, 8101N, 8112N 2101N	Switch on bottom housing. Set for fixed volume levels
Scout 900MX	Button on telephone's upper right edge

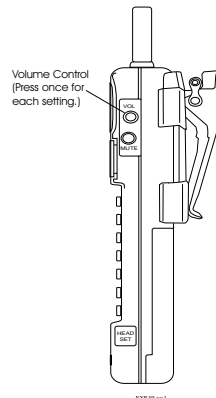
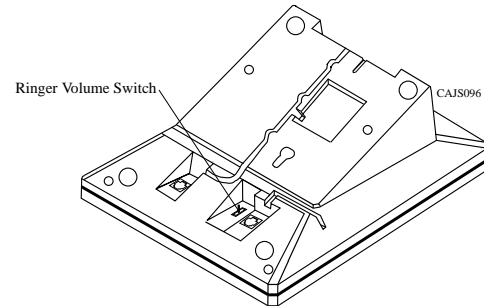
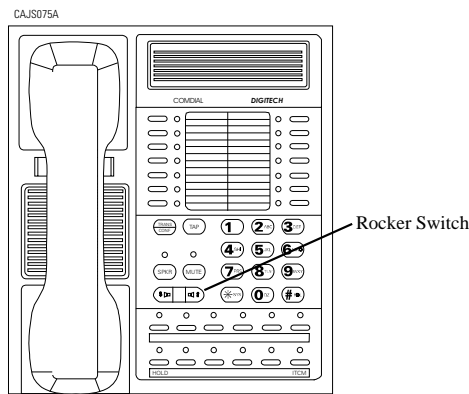

Locating The Telephone Ringer Volume Control

Display Intensity

You can adjust the intensity (brightness and contrast) of the display on LCD telephones any time the telephone is idle and on-hook.

To adjust the display intensity, press and hold the MUTE button on DigiTech telephones until you achieve the desired intensity or select **DISP** on *Impact* and *Impression* telephones through the interactive buttons.

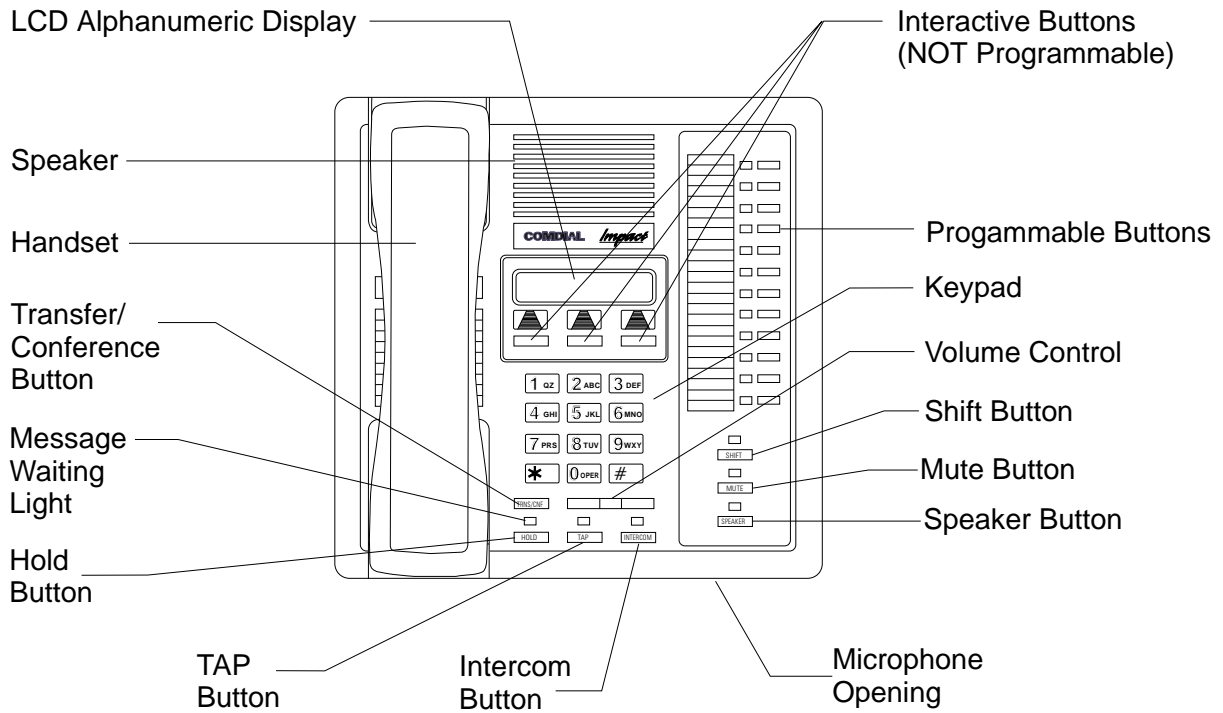

CAJS107

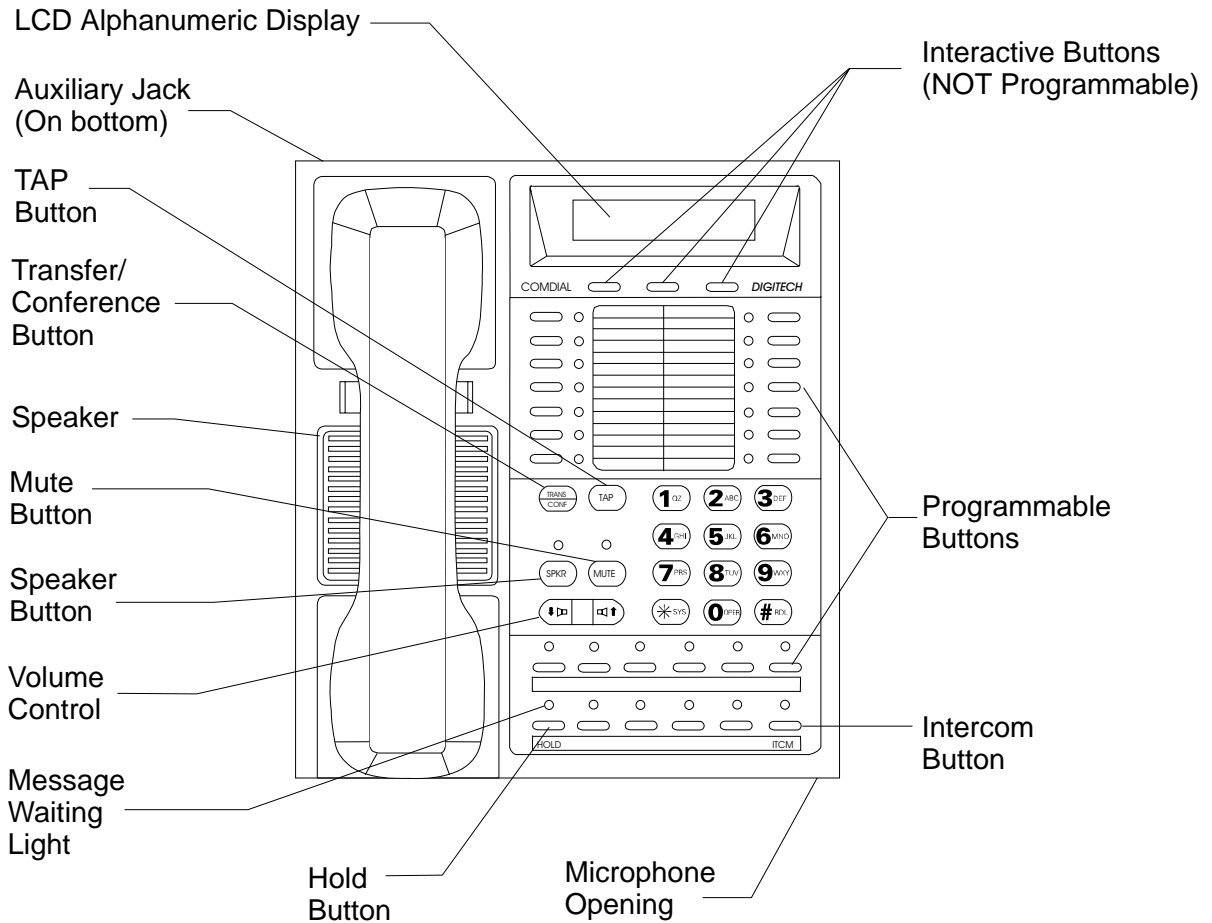

Locating DigiTech And Impact Controls And Indicators

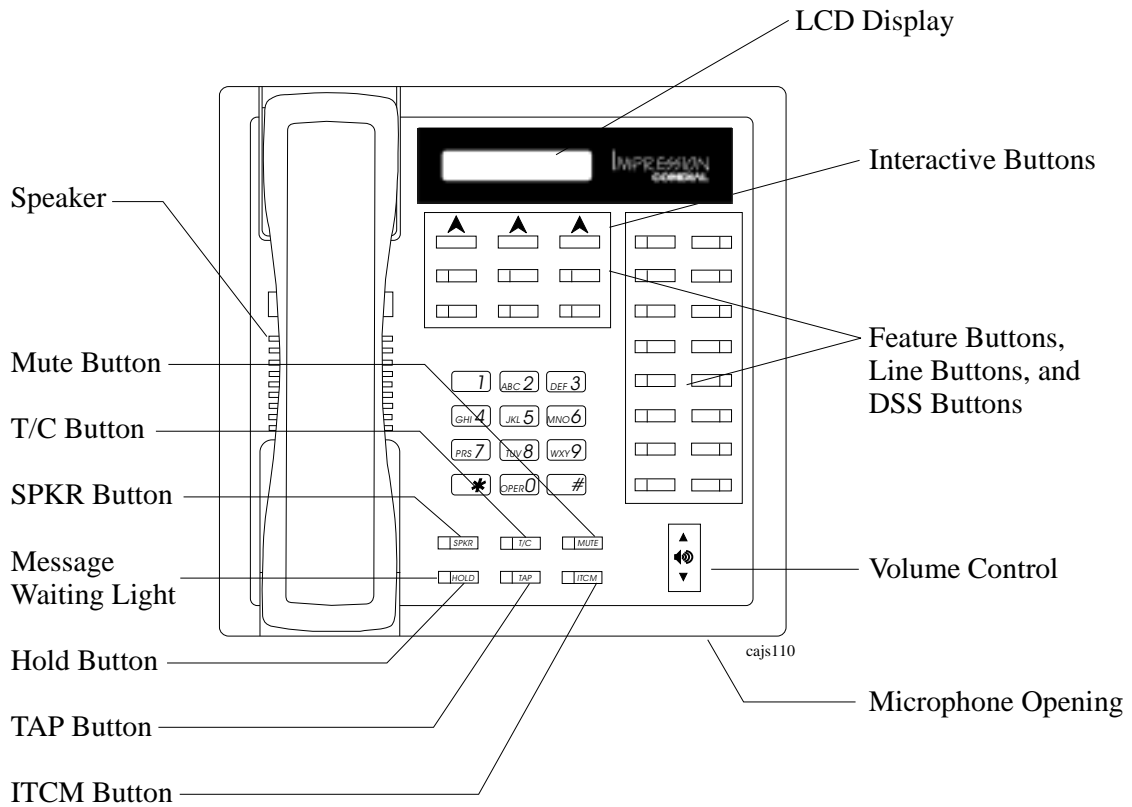

Locating Impression Controls And Indicators

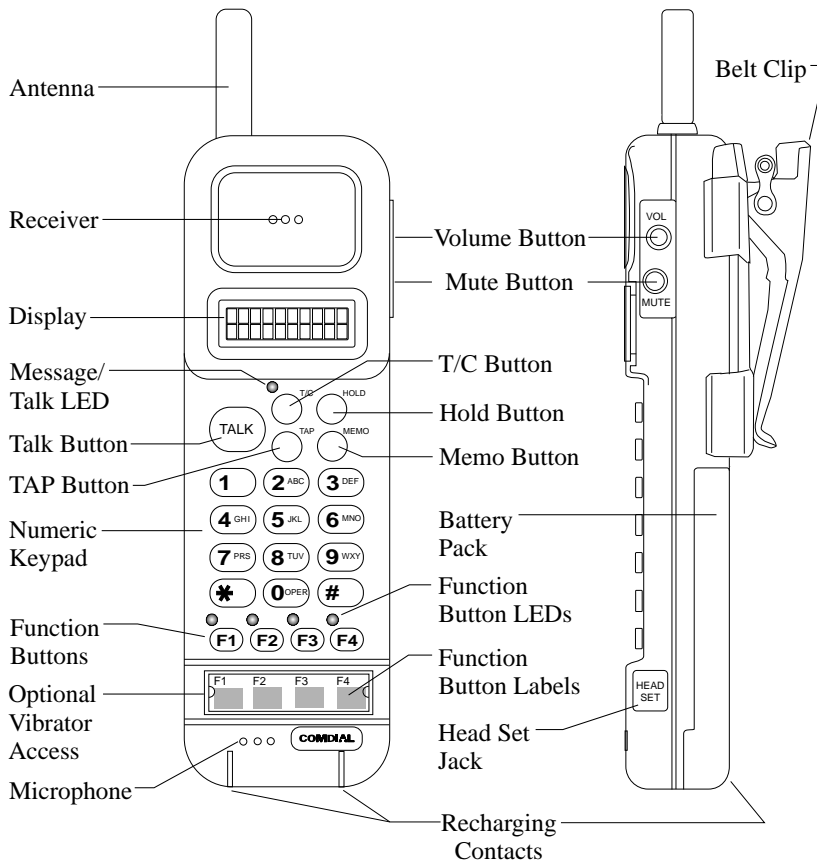

Locating Scout 900MX Controls And Indicators

1.7 Understanding The General Specifications

System Capacity

	J0408	J0816	J01632	JM408	JM008
Lines	4	8	16	4	0
Stations	8	16	32	8	8 IST
DSS/BLF Consoles	Two per station—one per station port	Two per station—one per station port	Two per station—one per station port	Two per station—one per station port	Not Applicable
Intercom Paths	Non-blocking	Non-blocking	Non-blocking	Non-blocking	Non-blocking
Maximum Simultaneous Intercom Conversations	Non-blocking	Non-blocking	Non-blocking	Non-blocking	Non-blocking
Paging Ports	1	1	1	Not Applicable	Not Applicable
Park Orbits	9	9	9	Not Applicable	Not Applicable
System Speed Dials	99	99	99	Not Applicable	Not Applicable
Station Speed Dials	10	10	10	Not Applicable	Not Applicable
Autodials	Unused Button	Unused Buttons	Unused Buttons	Not Applicable	Not Applicable
Power Fail Circuits	1	1	1	1	Not Applicable
Memory Retention After Power Loss	60 hours minimum				

Common Equipment Dimensions

	J0408	J0816	J1632	JM408 and JM008
Width (inches)	16.5	16.5	16.5	16.5
Height (inches)	21.3	27.1	27.6	9.25
Depth (inches)	3.8	3.8	4.5	1.75
Weight (pounds)	17.5	26	30.5	4

Station Dimensions

DigiTech		
	Multiline	Single-Line Proprietary
Footprint (inches)	8.625 X 7.658	6.5 X 8.5
Weight (pounds)	2.5	1.9

Impact			
	12-line	24-line	Single-Line Proprietary
Footprint (inches)	9.08 X 8.9	10.75 X 8.9	8.9 X 7.13
Weight (pounds)	2.3	2.6	1.75

Impression		
	Multiline	Single-Line Proprietary
Footprint (inches)	9.08 X 8.9	8.9 X 7.13
Weight (pounds)	2.5 (approx.)	1.9

Station Dimensions-continued

Scout 900MX		
	Base Unit	Handset
Footprint (inches)	7.30 X 5.12	8.15 X 2.19 X 1.85 with belt clip
Weight (ounces)	16 oz less AC adapter	8.5 oz with battery and belt clip

Conferencing

	J0408 and J0816	J1632
Maximum Combinations at Any One Time	1 five-way plus 1 three-way plus 2 SOHVA	4 five-way plus 1 three-way plus 1 SOHVA
	2 four-way plus 2 SOHVA	6 four-way plus 2 three-way
	1 four-way plus 3 three-way	3 four-way plus 9 three-way
	5 three-way plus 1 SOHVA	16 three-way

SMDA Storage Capacity

J0408	J0816	J1632
800	1600	1600

Station Cable Requirements

Type	2-wire (1-pair) twisted, non-shielded cable
Maximum Length	1000 feet with 24 gauge wire, 2000 feet with 22 gauge wire
Switching Principle	Digital, time division multiplexing (TDM). Provides non-blocking switching with stored program control

Operating Environment

Temperature	32-122 degrees F (0-50 degrees C)
Humidity	90 percent relative, non-condensing

Power Requirements

	J0408	J0816	J1632	JM408 and JM008
Voltage	90-129 VAC Single phase all models			
Current	0.6A	2.0 A	2.1A	Not Applicable
Power	70W	135W	150W	Not Applicable
Volt/Amps	80VA	190VA	200VA	Not Applicable

Terminations

Station	Standard 50-pin male connectors for connection to external distribution field
Line	Standard 6-conductor mini-jack (USOC 14C)

Music Interface

Input Level	3 Volts peak-to-peak maximum
Input Impedance	Approximately 500 Ohms
Connector	RCA phono jack

Station Message Detail Recording Port

Format	Serial, pseudo RS-232C
Parity	None
Data Bits	7 or 8 (programmable)
Stop Bits	1 or 2 (programmable)
Baud Rate	Programmable in class of service
Handshaking	X on -X off Hardware -CTS
Cable Length	500 feet maximum

PA Port

Output Level	400 Millivolts peak-to-peak (typical speech)
Output Impedance	Approximately 500 Ohms
Connector	RCA phono jack

Central Office Limits

Loop Limits	1900 Ohms maximum loop
Cable Insulation Leakage	15,000 Ohms minimum

Industry/Regulatory Standards

FCC Part 15, Class A RF emissions certified
FCC Part 68 Telco registered (fully protected)
IC CS03 Telco certified
UL 1459 safety approved by OSHA approved NAVLAP
CSA C22.2 No. 225 safety approved by OSHA approved NAVLAP
EIA RS478
Bell publication 48002 guidance
Hearing aid compatible handset

Regulatory Codes

FCC Registration Number—Key System	CVWUSA-61535-KF-E
FCC Registration Number—Hybrid System	CVWUSA-61536-MF-E
Facilities Interface Code (FIC)	02LS2
Universal Service Ordering Code (USOC)	9.0Y
Universal Service Ordering Code (USOC) Jacks	RJ14C or RJ21X
Ringer Equivalence Number(J0408, J0816, and J1632)	0.4B
Ringer Equivalence Number (JM408)	1.2B

1.7.1 Feature Codes

Feature		Dialing Code
All Call Page (Through Station Speakers)		INTERCOM, 87
Attendant Calling		INTERCOM, 0
Automatic Redialing		Programmed Button
Background Music	On	INTERCOM, * 1
	Off	INTERCOM, # 1
Automatic Call Back	Activate	INTERCOM, (ext no), * 6
	Cancel	INTERCOM, # 6
Station-to-Station Messaging	Activate	INTERCOM, (ext no), * 7
	Cancel	INTERCOM, # 7, (ext no)
LCD Messaging	Set	INTERCOM, * 02 (1-0)
	Cancel	INTERCOM, # 02
Call Forward	Personal	INTERCOM, * 05, (ext no)
	Cancel	INTERCOM, # 05
	All Calls	INTERCOM, * 5, (ext no)
	Cancel	INTERCOM, # 5
Call Park	Park Orbits 1-9	INTERCOM, * (91-99)
	Pick Up	INTERCOM, # (91-99)
Call Pick Up	Directed	INTERCOM, * 4, (ext no)
	Group	INTERCOM, # 4
Call Waiting Tone	Send	INTERCOM, (ext no), * 01
	Cancel	Hang Up
Do Not Disturb	Set	Programmed Button
	Cancel	Programmed Button
Executive Override		INTERCOM, (ext no), * 03
External Page		INTERCOM, 89
Handsfree Answer Inhibit	Set	MUTE
	Cancel	MUTE
Hold	Manual	HOLD
	Exclusive	HOLD, HOLD
	Direct	INTERCOM, * 90, (ext no)
	Direct Hold Pick Up	INTERCOM, # 90
Line Answer From Any Station		INTERCOM, 80
Line Group Access	Group 1	INTERCOM, 9
	Group 2	INTERCOM, 81
	Group 3	INTERCOM, 82
	Group 4	INTERCOM, 83
Line Queuing		
	Enable Line Group	INTERCOM, (gp code), * 8
	Cancel	INTERCOM, # 8
Meet Me Answer Paging		INTERCOM, 88
Message Waiting	Set	INTERCOM, * 3, (ext no)
	Cancel From Idle	INTERCOM, # 3, (ext no)
	Cancel On Line	INTERCOM,
	Retrieve Message	INTERCOM, HOLD
Night Transfer (Attendant)	On	INTERCOM, * # 03, Programmed Button
	Off	INTERCOM, * # 03, Programmed Button
Personal Ringing Tones	Set Tones 1-6	INTERCOM, * * 4 (1-6)

Pulse/Tone Switching		#
Redial Last Dialed Number		#
Save Number Redial	Use	HOLD, Programmed Button
	Store	Programmed Button
Service Observing		INTERCOM, # 03, (ext no)
Speed Dial	Station	0-9
	System	* 01-99
TAP (on line)	Activate	INTERCOM, #04
Toll Restriction Override	Activate	INTERCOM, **6 (extension number, code)
Tracker Pager	Enable	INTERCOM, *06
	Disable	INTERCOM, #06
	Send Message	INTERCOM, #01
Voice Announce Block	Block	INTERCOM, * 2
	Unblock	INTERCOM, # 2
Zone Page	Zone 1	INTERCOM, 84
	Zone 2	INTERCOM, 85
	Zone 3	INTERCOM, 86

1.7.2 System Ringing Patterns

Ring Type	Ring Cadence
CO/PBX Line Ring	Host system ring cadence
Intercom Tone Signaling	Two 150 msec. tone bursts every four seconds
Voice Signaling alert	One 215 msec. tone burst
Timed hold recall at station that put call on hold	Three 150 msec. tone bursts at the end of each timeout period
Call back alert	One 80 msec. tone burst followed by three 150 msec. tone bursts and one 80 msec. tone burst
Queue Enabled	
Call forward alert	One 80 msec. tone burst
Transfer ringing	Two 1.1 sec tone busts every four seconds

Tone Type	Tone Cadence
Dial Tone	Continuous on
Called station ring-back	One sec. on and three sec. off
Base level program entry	80 msec. tone burst sounded once
Error tone—incorrect entry	530 msec. tone burst sounded three times
All-call and zone paging notification tone	80 msec. tone burst followed by 280 msec. tone
Busy tone	530 msec. tones sounded continuously
Override feature not allowed	
Night transfer feature not allowed	
Call waiting tone	Three 80 msec. tone bursts sounded once
Called station in do-not-disturb mode	140 msec. tone burst sounded twice every 1.5 sec.
Call-back busy feature on	260 msec. tone burst sounded once
System is awaiting memory dial number or key mapping entry after location is specified	80 msec. tone burst sounded continuously
Override feature on warning tone	Six 100 msec. tone bursts sounded for 1.5 secs.
SOHVA tone	
DISD ringback tone	Dual 440/480 Hz tone sounded 1 sec. on/1 sec. off
DISD dial tone	381 Hz tone sounded continuously
DISD confirmation tone	Two 125 sec. bursts of 381 Hz tone sounded once
DISD busy/error tone	Three 500 msec. bursts of 381 Hz tone sounded once

1.8 Seeking Repair Assistance

If your common equipment cabinet or individual stations need repair, you may return the equipment to Comdial. Comdial will, at its option, either repair or replace it. There is a fixed charge for this repair. For information on this charge, call or write to the address given below.

Comdial
P.O. Box 7266
Charlottesville VA 22906
Attn: Repair Department
Telephone: (804) 978-2400
1-800-877-4448

If you do return equipment for repair, pack it carefully to prevent damage. Any damages during shipment are your responsibility. You should ship the equipment freight or postage prepaid. The shipping address is given below.

Comdial
1180 Seminole Trail
Charlottesville, VA 22901
Attention Repair Department

This page remains blank intentionally.



Installing The DSU II Digital Telephone System

<u>Section</u>	<u>Title</u>	<u>Page</u>
2.1	Considering the Mounting Requirements	2-4
2.1.1	Tools And Hardware	2-5
2.1.2	Underwriters Laboratories Installation Notice	2-5
2.1.3	Hybrid Installation	2-5
2.2	Mounting The Cabinet	2-6
2.3	Making The AC Power Connection	2-8
2.3.1	Identifying The Fuses	2-8
2.3.2	Grounding The System	2-10
2.4	Connecting The Lines	2-12
2.4.1	Detailing The Line Connections	2-14
2.4.2	Reassigning The Line Ports	2-14
2.4.3	Protecting The Lines.....	2-14
2.5	Connecting The Stations	2-16
2.5.1	Grounding The Unused Station Cables	2-17
2.5.2	Relocating The Stations	2-17
2.5.3	Installing The Cable Clips	2-17
2.5.4	Connecting Stations To The J0408.....	2-19
2.5.5	Connecting Stations To The J0816.....	2-20
2.5.6	Connecting Stations To The J1632.....	2-21
2.5.7	Wall Mounting The Telephone Stations.....	2-23

Section	Title	Page
2.6	Installing DSS/BLF Consoles	2-26
2.7	Connecting A Power Failure Station.....	2-28
2.8	Using The Auxiliary Equipment Interface	2-29
2.9	Common The Audible And Auxiliary Ringing Interface.....	2-30
2.9.1	Connecting Outside Lines	2-30
2.9.2	Connecting Selected Ports	2-30
2.10	Using The External Paging Interface	2-32
2.11	Using A Line Port As An External Paging Interface.....	2-33
2.12	Connecting Data Devices To The System	2-34
2.12.1	Making Modular Jack Data Connections	2-34
2.12.2	Making The Common Equipment Data Connections.....	2-36
2.12.3	Connecting A Personal Computer For Remote Programming	2-38
2.13	Using The Music Interface	2-40
2.14	Using The Add-On Expansion Module	2-41
2.14.1	Using The JM408 Module	2-41
2.14.2	Using The JM008 Module	2-44
2.14.3	Installing An Add-On Expansion Module	2-48
2.15	Checking The System Installation	2-50
2.15.1	Checking The Resistance.....	2-50
2.15.2	Checking The Voltage	2-50
2.15.3	Checking The General Operating Conditions	2-51

Section	Title	Page
2.16	Isolating Failures.....	2-51
2.16.1	Checking The System Status Indicator.....	2-51
2.16.2	Testing The Stations	2-51
2.17	Loading And Up-Grading The System Software	2-52
2.17.1	Introducing The Software Key	2-52
2.17.2	Introducing The Software Disks	2-53
2.17.3	Loading The Software	2-54
2.18	Installing The System Options And Accessories	2-60
2.18.1	Installing The Battery Back Up Assembly	2-60
2.18.2	Installing the Analog Terminal Interface.....	2-64
2.18.3	Installing the Data Interface Unit	2-72
2.18.4	Supporting Caller Identification Service	2-76
2.18.5	Supporting The Tracker Paging System	2-80
2.18.6	Supporting DVA Operation.....	2-82
2.18.7	Installing The Personal Computer Interface Unit.....	2-84
2.18.8	Connecting The Versatile Voice Processing Voice Mail System	2-86
2.19	FCC Rules And Regulations	2-88

2.1 Considering The Mounting Requirements

The following requirements will help you to install the DSU II digital telephone system.

- Locate the equipment cabinet within four feet of an AC electrical outlet dedicated exclusively to the use of this equipment. The outlet must be a 117 VAC 15 AMP circuit with a third-wire ground supplied to a standard electrical outlet (NEMA 5-15R).
- Mount the common equipment within 25 feet of the TELCO/PBX jacks. The recommended nominal distance is 7 feet.
- Choose a secure and dry mounting location that has adequate ventilation. The temperature range of the location must be within 32–122 degrees F (0–50 degrees C) and that the relative humidity is less than 90 percent, non-condensing.
- If the mounting surface is damp or if it is made of concrete or masonry material, you must attach a backboard to the mounting surface for mounting the common equipment. Suitable mounting backboards are available commercially or you can construct one from 3/4-inch plywood by cutting it to size.

2.1.1 Tools And Hardware

You will need the following tools and materials to install the common equipment.

- Fasteners—wood screws (1/4 x 1-inch round head), toggle bolts, or wall anchors,
- Screwdriver—to match fasteners,
- Electric drill—if prepared holes are required,
- Connecting tool—for fastening wires to a type-66 connector block,
- Crimping tool—for 623-type modular plugs,
- Volt/Ohm Meter.

2.1.2 Underwriters Laboratories Installation Notice

Per The Underwriters Laboratories standard 1459, 2nd edition, be aware of the following precautions when installing telephone equipment that is to be directly connected to the telephone company network:

- Never install telephone wiring during a lightning storm,
- Never install telephone jacks in wet locations unless the jack is specifically designed for wet locations,
- Never touch un-insulated telephone wires or terminals unless the telephone line has been disconnected at the network interface,
- Use caution when installing or modifying telephone lines.

2.1.3 Hybrid Installation

Whenever a programmer assigns lines to line groups, the digital telephone system automatically assumes the hybrid mode. Your local telephone company may charge a higher monthly fee for operation of a hybrid system; therefore, the FCC requires that you report the equipment-type category designation number (KF for key system, MF for hybrid system) to the telephone company at the time of installation.

FCC Registration Numbers

Key System	CVWUSA-61535-KF-E
Hybrid System	CVWUSA-61536-MF-E

2.2 Mounting The Cabinet

After thoroughly reviewing Section 2.1 and fully understanding its subject matter, use the following procedure to mount the common equipment cabinet

1. Unpack and carefully inspect all equipment for shipping damage. Notify the shipper immediately of any damages that you find. Verify that the packages contain all parts and accessories needed for proper installation and operation.
2. If the mounting location requires a backboard, attach it securely to provide a stable mounting surface for the equipment.
3. Refer to Figure 2-1 or to the PP032-001 mounting template included in the literature that accompanies the common equipment cabinet for the locating dimensions required for the three mounting screws, and mark their locations on the mounting surface.
4. Drill holes in the mounting surface of a proper size to accommodate the hardware being used. If necessary, prepare these holes with inserts, anchors or other attachment devices as dictated by the type of mounting surface.
5. Insert the two top screws into the mounting surface and tighten them to within approximately 1/8-inch of the surface.
6. Hang the cabinet on the top screws using the mounting holes located on the rear of the cabinet. Note that these holes are elongated with an enlargement at one end. This feature allows the cabinet to snap down on the screws to secure the mounting when the cabinet is hung on them.
7. Insert a third screw through the mounting tab located on the lower edge of the cabinet and into the mounting surface, and tighten it into place.
8. Place the individual telephone stations as desired and in keeping with accepted industry and office standards. You can wall mount a telephone station if necessary (see Section 2.5.7 for details).

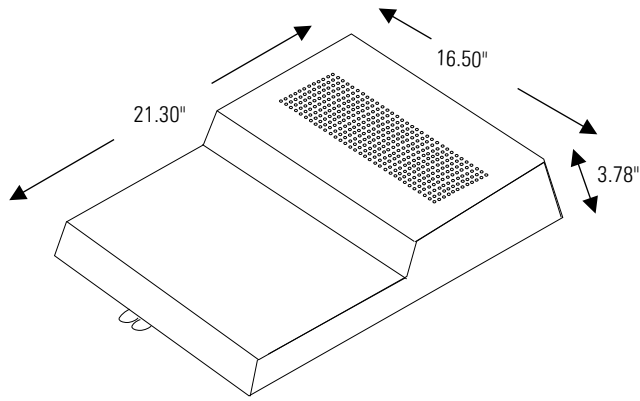

4-Line, 8-Station Base Unit

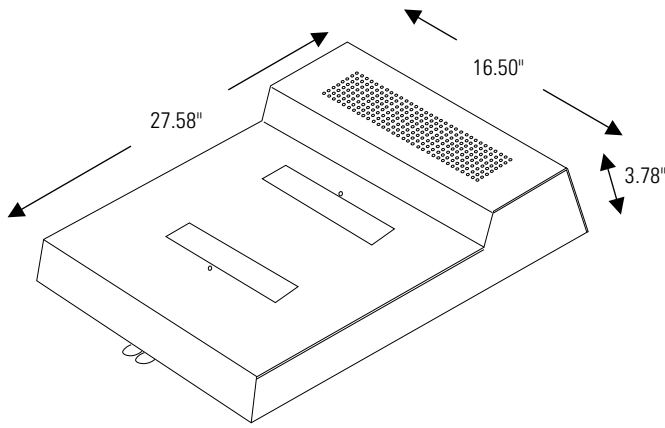
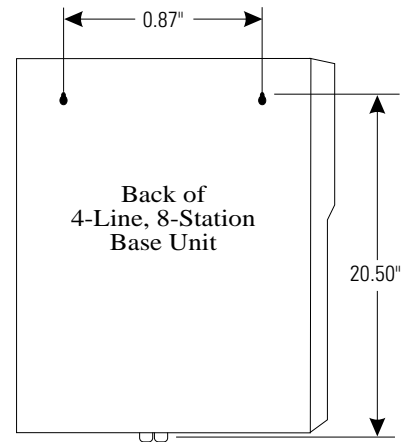

8-Line, 16-Station Base Unit

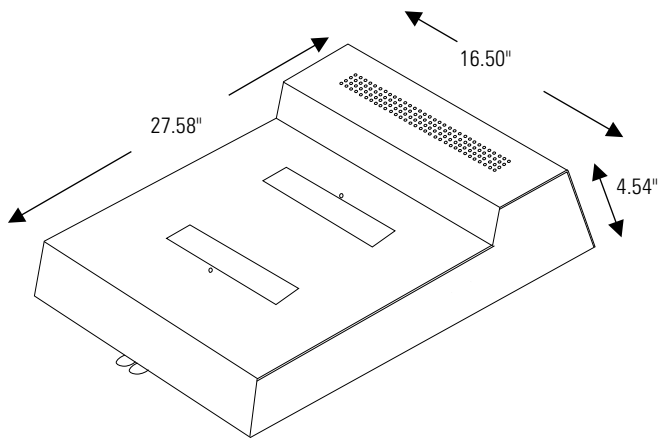
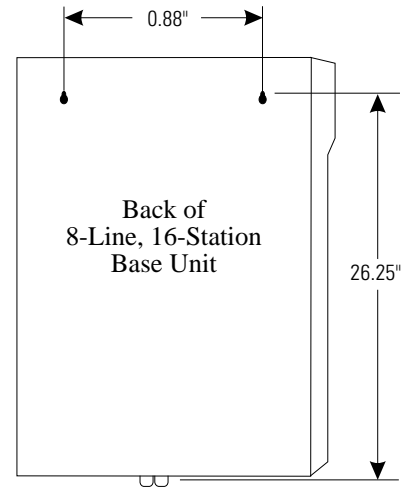

16-Line, 32-Station Base Unit

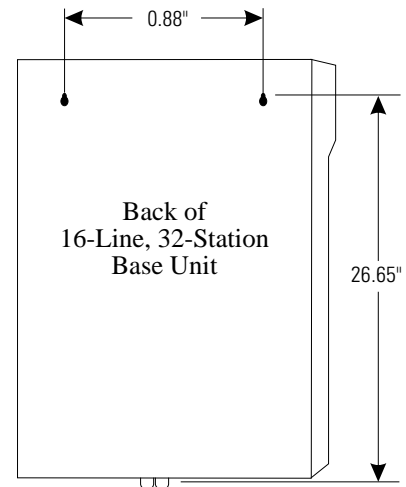

DSU250.CDR

Detailing The DSU II Cabinet Dimensions

2.3 Making The AC Power Connection

You must employ a dedicated 117VAC 15 AMP circuit, with a third-wire ground, supplied to a standard electrical outlet (NEMA 5-15R) for the AC power connection.

- For added equipment protection, connect a plug-in power line surge protector between the power cord and the AC outlet.
- Thoroughly check out the installation before connecting the power cord to an electrical outlet to apply AC power to the system.

2.3.1 Identifying The Fuses

The system is protected against short circuit damage by a fuse located on the right side of the common equipment cabinet. Always replace the fuse with one of the same value and type; otherwise, equipment damage could result.

Comparing Cabinets And Their Fuse Types

Cabinet	Fuse Value
J0408	1A 250V slow-blow type
J0816	3A 250V slow-blow type
J1632	3A 250V slow-blow type

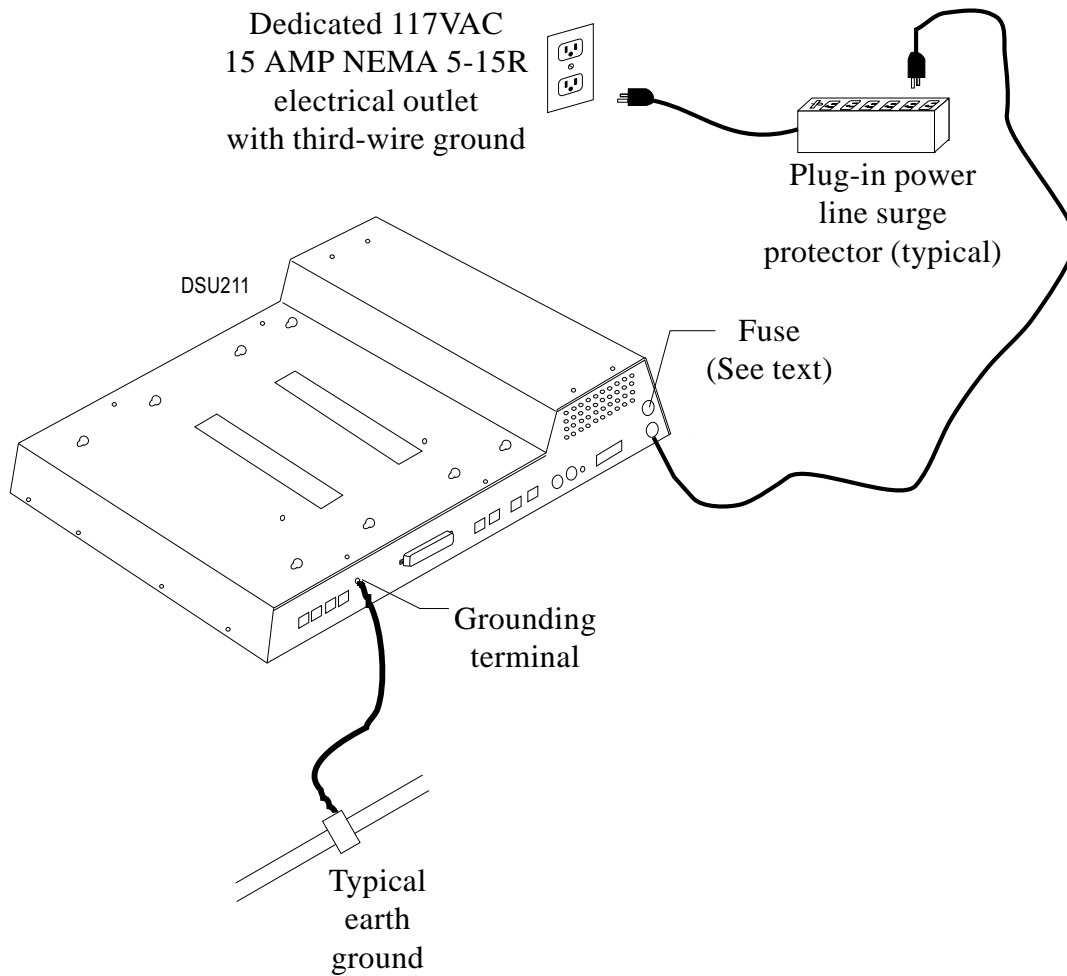

Making The AC Power Connections

2.3.2 Grounding The System

If spare conductors exist in the cables between the station and the 66M-xx connector blocks, it is good practice to connect them to an earth ground. Doing this may help prevent them from inducing radio frequency and/or AC interference into the system. It is also good practice to disconnect any unused station jacks from the connector block and ground that wiring to an earth ground as well.

Transient voltage spikes, if induced onto CO or CENTREX lines, can travel through the cable and into the common equipment. The telephone company offers basic protection against this condition but it is usually designed to protect the central office circuits. While it will also provide some protection to the common equipment, you should not rely upon it for total protection. To help ensure that external over-voltage surges do not damage the system, you should install and properly ground primary protection devices, such as gas discharge tubes or similar devices, on all lines. While the line boards have internal secondary surge protection on all line ports, in order for this protection to be effective, you **MUST** connect the common equipment cabinet to a reliable, effective earth ground.

Proper DSU grounding is necessary for trouble-free operation and personnel safety. The DSU has the following three types of grounds:

- **Service Ground**—a neutral power line wire that is connected to the ground bus in the premises' AC power panel,
- **System Ground**—a non-current carrying power line wire that is connected to the ground bus in the premises' AC power panel,
- **Frame Ground**—a low impedance conductor that places the common equipment cabinet at reference ground potential. The frame ground provides the greatest safety by limiting electrical potential between non-current carrying parts of the system. The common equipment cabinet provides a ground stud on its cabinet for access to its frame ground.

Effective grounding requires that you connect the frame ground to a good earth ground. A good earth ground is one such as the ground bus in the premises' AC power panel or a public metallic cold water pipe at a point immediately at its entrance to the premises and ahead of any meters, pumps, or insulating sections that have been added for vibration reduction. Avoid using the premises' structural steel frame as it may not be at earth ground potential. Make the ground connection with #10 or #12 insulated, solid copper grounding wire. **Keep the ground wire separate from the three-wire AC line cord ground, do not splice it, and keep it as short as possible.**

The impedance of the wiring between the common equipment cabinet and the earth ground must not exceed 0.25 ohms and the impedance between the earth ground and the power company's reference standard ground must not exceed 4 ohms. Use an acceptable low impedance measuring device to measure the impedance of these paths. The #10 or #12 wire size will minimize the wiring impedance; however, if the impedance between earth ground and the power company's standard reference ground exceeds 5 ohms, contact the local power company. The ground path must always be of sufficient current-carrying capacity to prevent a build up of voltages that may result in circuit noise, hazard to personnel, or equipment damage.

Be sure that all of the ground connections are without splices and are visible for inspection and maintenance. Tag all of the ground connections with a sign that reads: *Do Not Remove Or Disconnect*.

If you install expansion modules on the base cabinet, attach at least a #10 or #12 insulated, solid copper wire between the frame ground stud on the expansion module(s) to the frame ground stud on the base cabinet.

Remember, if spare conductors exist in the cables that run between the stations and the 66M-xx connector blocks, it is good practice to connect them to earth ground. Doing this may help prevent them from introducing radio frequency and/or AC interference into the system. Also remember that it is good practice to disconnect any unused station jacks from the connector block and ground that wiring to earth ground as well.

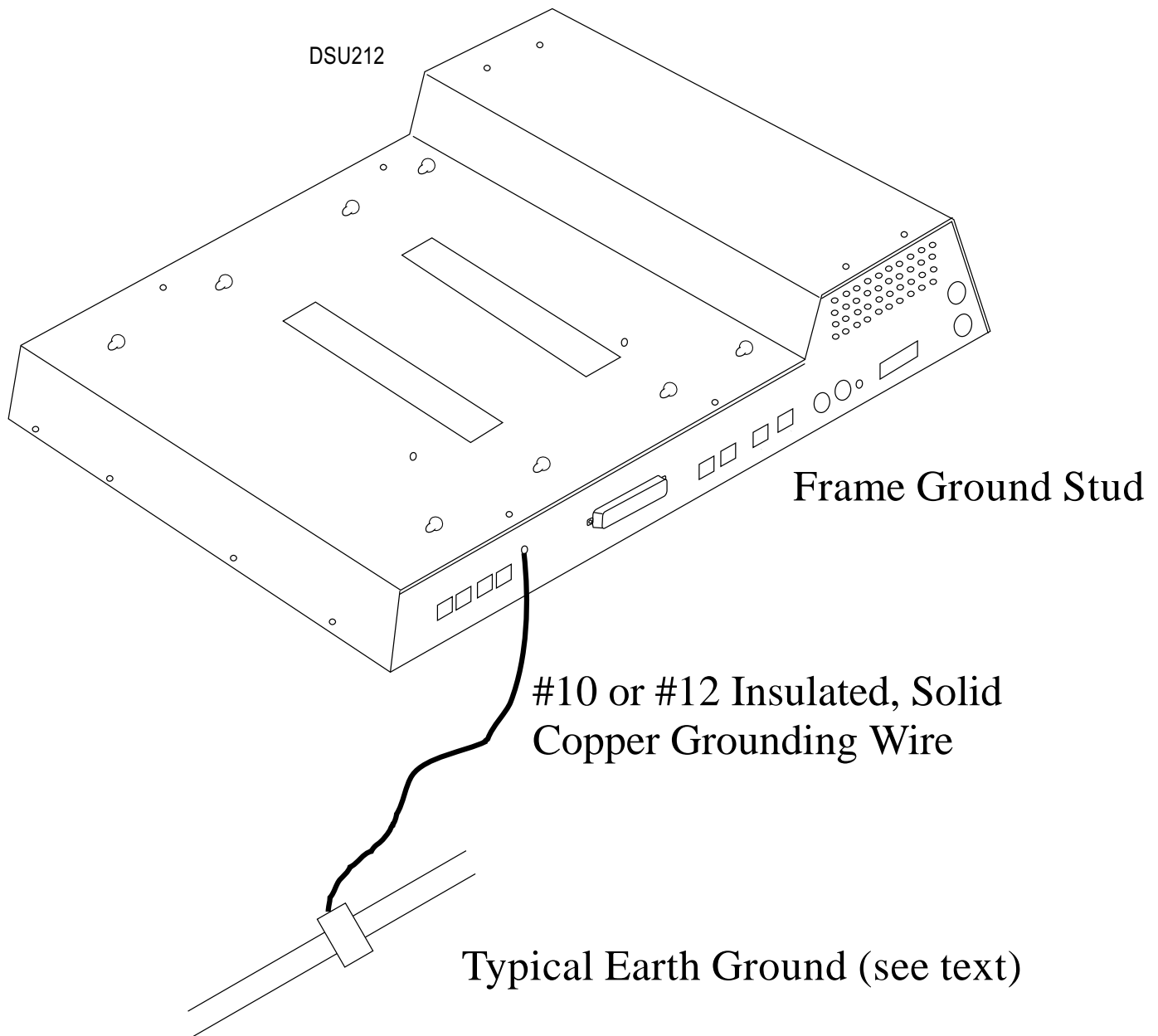

Grounding The System

2.4 Connecting The Lines

The line terminations for the common equipment cabinet are standard modular plug/jack connections. Line configuration must be loop start only. Each modular jack provides termination for two lines. Modular line jacks 1 and 2 also provide termination for an auxiliary pair in addition to the two outside lines. The outside line termination can be a type 66M-xx connector block or individual 6-position modular jacks. The line cord that is routed between the outside line termination and the common equipment termination should be twisted-pair wiring. The J0408, J0816 and J1632 common equipment supports the installation of up to 4, 8, or 16 lines, respectively. Add-on expansion modules are available to expand the line capacity of the systems.

4-Line, 8-Station Base Unit

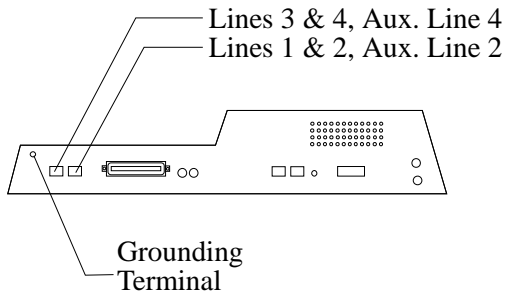

8-Line, 16-Station Base Unit

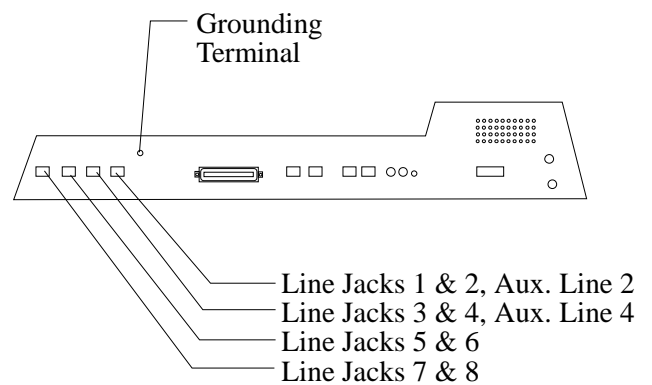

16-Line, 32-Station Base Unit

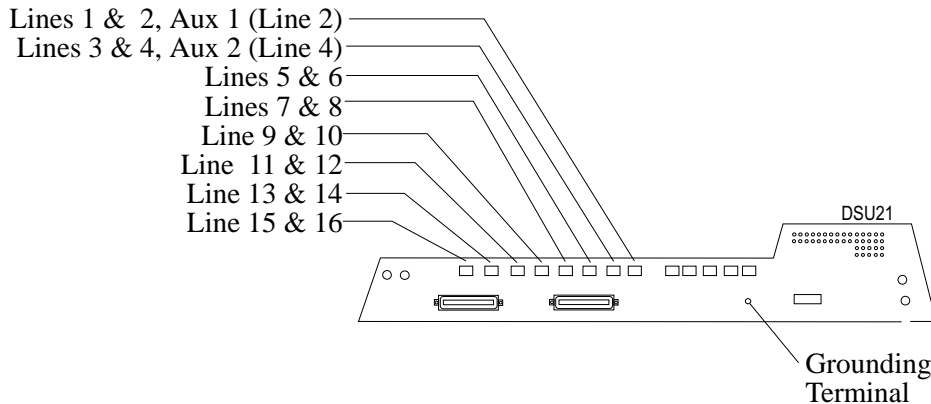

Locating The Line Connections

(Typical 8-Line, 16-Station Base Unit Shown)

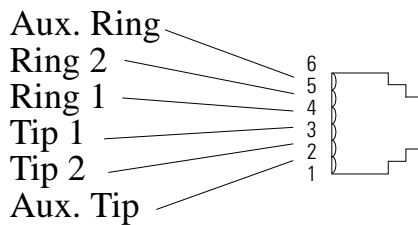
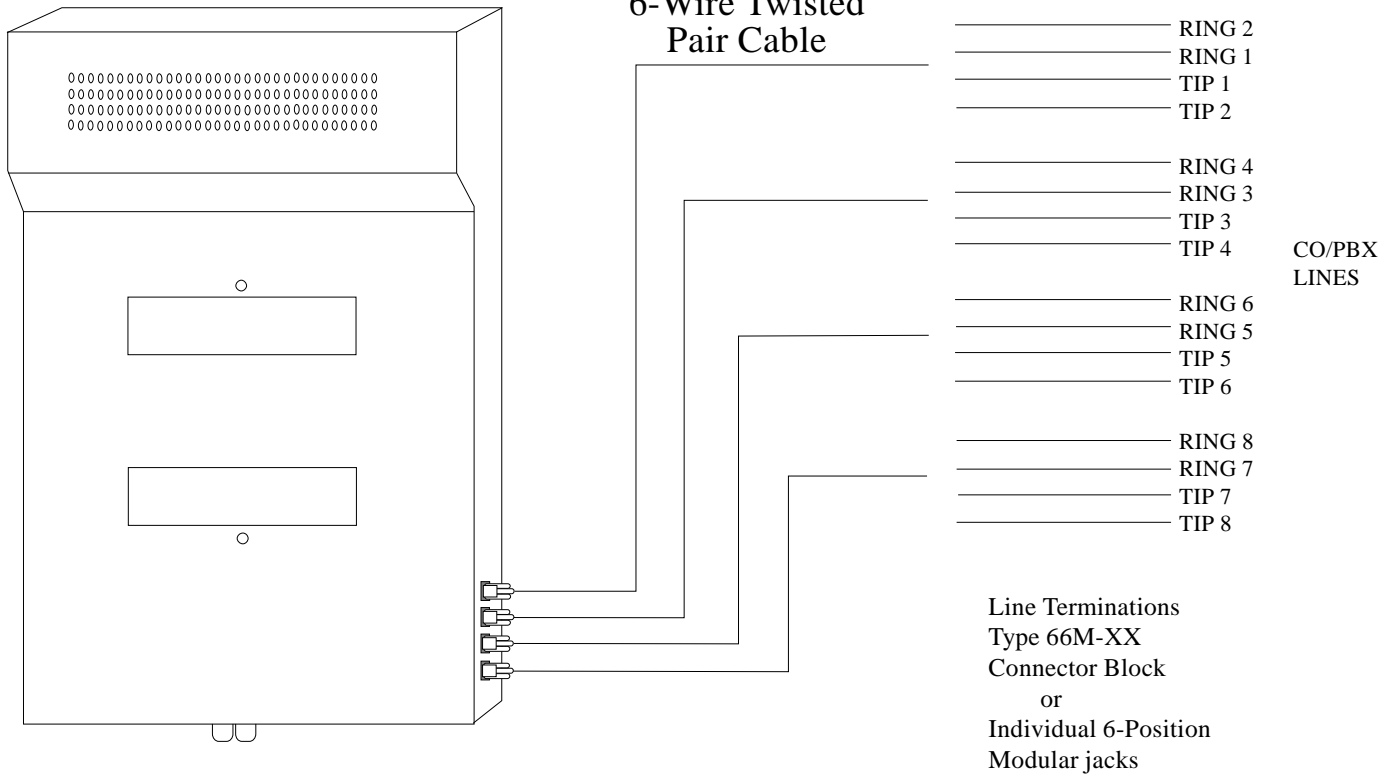

Pin designation for
Line Jacks 1 and 2

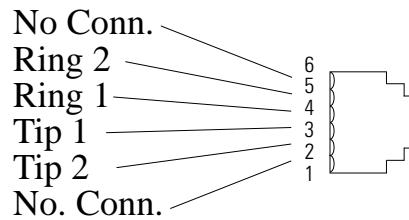

Pin designation for
Line Jacks 5 and 6

CAJS083

Detailing The CO Interface

2.4.1 Detailing The Line Connections

The table on the next page shows the line connection details for all three of the common equipment base units. Jacks one and two are the same for all three cabinets, jacks three and four are the same for both the J0816 and J1632 cabinets, and jacks five through eight are only available on the J1632 cabinet.

2.4.2 Reassigning The Line Ports

After you have initially connected a line to a particular line port and programmed its attributes (or left it with the system defaulted values), you can reassign the line and its attributes to a different port by programming action if you wish. Refer to Chapter 3 for the line to line port reassignment programming details.

CAUTION

While this feature allows you to make adds, moves, and changes without relocating the line wiring, it is not a substitute for correct wiring and should not be used as such. Be sure to record any reassignments that you make.

2.4.3 Protecting The Lines

Transient voltage spikes, if induced onto CO or CENTREX lines, can travel through the cable and into the common equipment. The telephone company offers basic protection against this condition but it is usually designed to protect the central office circuits. While it will also provide some protection to the common equipment, it should not be relied upon for total protection. To help ensure that external over-voltage surges do not damage the system, the manufacturer recommends that gas discharge tubes, or similar primary protection devices, be installed and properly grounded on all lines (a selection of solid-state protection devices that are useful for this purpose is available from ITW Linx, Elk Grove Village, Illinois 60007).

Understanding The Line Connection Details

Common Equipment Type	Line Jack	Pin No.	Connection	Telephone Number
J0408, J0816, and J1632	1	1	Auxiliary 1 (Line 2) Tip	
		2	Line 2 Tip	
		3	Line 1 Tip	
		4	Line 1 Ring	
		5	Line 2 Ring	
		6	Auxiliary 1 (Line 2) Ring	
	2	1	Auxiliary 2 (Line 4) Tip	
		2	Line 4 Tip	
		3	Line 3 Tip	
		4	Line 3 Ring	
		5	Line 4 Ring	
		6	Auxiliary 2 (Line 4) Ring	
J0816 and J1632	3	1	No Connection	
		2	Line 6 Tip	
		3	Line 5 Tip	
		4	Line 5 Ring	
		5	Line 6 Ring	
		6	No Connection	
	4	1	No Connection	
		2	Line 8 Tip	
		3	Line 7 Tip	
		4	Line 7 Ring	
		5	Line 8 Ring	
		6	No Connection	
J1632	5	1	No Connection	
		2	Line 10 Tip	
		3	Line 9 Tip	
		4	Line 9 Ring	
		5	Line 10 Ring	
		6	No Connection	
	6	1	No Connection	
		2	Line 12 Tip	
		3	Line 11 Tip	
		4	Line 11 Ring	
		5	Line 12 Ring	
		6	No Connection	
	7	1	No Connection	
		2	Line 14 Tip	
		3	Line 13 Tip	
		4	Line 13 Ring	
		5	Line 14 Ring	
		6	No Connection	
	8	1	No Connection	
		2	Line 16 Tip	
		3	Line 15 Tip	
		4	Line 15 Ring	
		5	Line 16 Ring	
		6	No Connection	

2.5 Connecting The Stations

The DSU II digital telephone system supports the operation of proprietary Comdial telephones.

The J0408, J0816 and J1632 common equipment supports the installation of up to eight, 16, or 32 telephones, respectively. Add-on expansion modules are available to expand the station capacity of the systems. You can add one expansion module to the J0408, and two expansion modules to the J0816 and J1632. The JM408 expansion module provides interface for eight proprietary stations (plus interface for four lines) while the JM008 expansion module provides interface for eight industry-standard devices.

Connections between the common equipment and the stations are typically via type 66M-xx connector blocks which are cable connected to the common equipment's 50-pin male connector. The connector block is, in turn, wired to modular jacks that accept the modular line cord connected between it and the telephones.

The maximum distance allowed from the common equipment to the stations is per the following list:

- Multiline Telephones—1000 feet using #24 gauge, twisted-pair cable or 2000 feet using #22 gauge cable

When installing the system telephones keep in mind that each station port supports only one proprietary telephone and the system does not allow you to bridge two stations to a single modular jack.

Always route station wiring a minimum of 12 inches from any other parallel wires or electrical devices. If electrical noise or RF energy is at a high level, you may need to use shielded cable with the shield connected to the cabinet ground lug.

2.5.1 Grounding The Unused Station Cables

Remember, if spare conductors exist in the cables that run between the stations and the 66M-xx connector blocks, it is good practice to connect them to earth ground. Doing this may help prevent them from introducing radio frequency and/or AC interference into the system. Also remember that it is good practice to disconnect any unused station jacks from the connector block and ground that wiring to earth ground as well.

Remove insulation and twist together all spare wires at the wall outlet. Ground the wires at the 66M-xx to the common equipment cabinet ground lug.

2.5.2 Relocating The Stations

The Comdial proprietary telephones identify themselves to the system when you install them. The system assigns an extension number and all other programmable attributes to station ports as a default that you can reprogram as needed. Plus, you can use programming action to reassign attributes of one station port to a different station port if you wish. Refer to the automatic station relocation programming procedure and the station-to-station programming procedure found in Chapter 3.

NOTE: The system will not allow you to relocate the station 10 to station port 10 assignment.

CAUTION

While this feature allows you to make adds, moves, and changes without relocating the station wiring, it is not a substitute for correct wiring and should not be used as such. Be sure to record any reassignments that you make.

2.5.3 Installing The Cable Clips

Each cabinet-mounted 50-pin male connector is equipped with a retaining clip. This clip is designed to secure the mated connection once it is made. The clip does this by snapping into a slot on the cable-mounted connector when it is pressed together with the cabinet-mounted connector. This retaining clip must be pulled back slightly to unsnap it before the connectors can be separated.

4-Line, 8-Station Base Unit

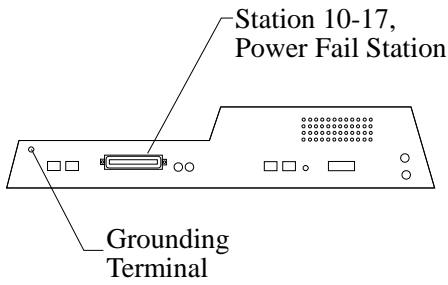

8-Line, 16-Station Base Unit

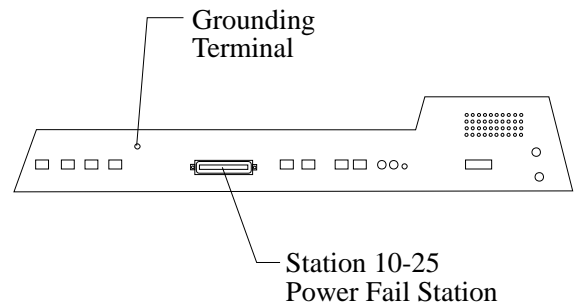

16-Line, 32-Station Base Unit

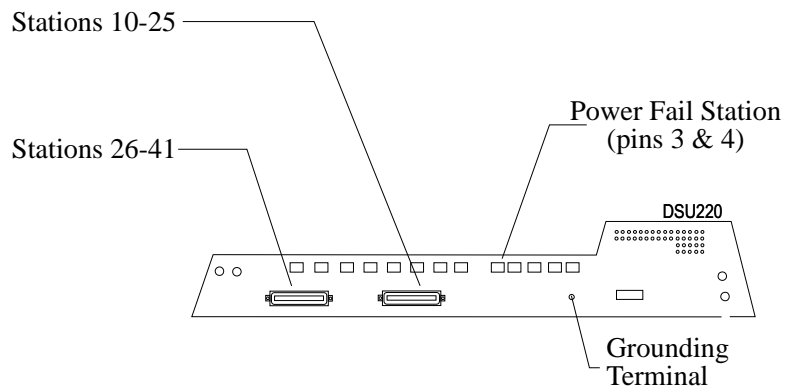

Locating The Station Connections

2.5.4 Connecting Stations To The J0408

This table shows the color-coded connections for a J0408 common equipment cabinet.

Connecting Stations To The J0408 Common Equipment Cabinet

25-Pair Connections			Two-Wire Connections		Station Connections		
Wire Color	Pair	Pin No.	Clip Term.	Pair	Wire Color	Station	Location
White-Blue	1	26	1	Signal Path	Green	10	
Blue-White		1	2		Red		
White-Orange	2	27	3	Signal Path	Green	11	
Orange-White		2	4		Red		
White-Green	3	28	5	Signal Path	Green	12	
Green-White		3	6		Red		
White-Brown	4	29	7	Signal Path	Green	13	
Brown-White		4	8		Red		
White-Slate	5	30	9	Signal Path	Green	14	
Slate-White		5	10		Red		
Red-Blue	6	31	11	Signal Path	Green	15	
Blue-Red		6	12		Red		
Red-Orange	7	32	13	Signal Path	Green	16	
Orange-Red		7	14		Red		
Red-Green	8	33	15	Signal Path	Green	17	
Green-Red		8	16		Red		
Red-Brown	9	34	17				
Brown-Red		9	18				
Red-Slate	10	35	19				
Slate-Red		10	20				
Black-Blue	11	36	21				
Blue-Black		11	22				
Black-Orange	12	37	23				
Orange-Black		12	24				
Black-Green	13	38	25				
Green-Black		13	26				
Black-Brown	14	39	27				
Brown-Black		14	28				
Black-Slate	15	40	29				
Slate-Black		15	30				
Yellow-Blue	16	41	31				
Blue-Yellow		16	32				
Yellow-Orange	17	42	33				
Orange-Yellow		17	34				
Yellow-Green	18	43	35				
Green-Yellow		18	36				
Yellow-Brown	19	44	37				
Brown-Yellow		19	38				
Yellow-Slate	20	45	39				
Slate-Yellow		20	40				
Violet-Blue	21	46	41				
Blue-Violet		21	42				
Violet-Orange	22	47	43				
Orange-Violet		22	44				
Violet-Green	23	48	45				Common Audible
Green-Violet		23	46				
Violet-Brown	24	49	47				Station 17 Audible
Brown-Violet		24	48				
Violet-Slate	25	50	49				Power Fail Station
Slate-Violet		25	50				

2.5.5 Connecting Stations To The J0816

This table shows the color-coded connections for a J0816 common equipment cabinet.

Connecting Stations To The J0816 Common Equipment Cabinet

25-Pair Connections			Two-Wire Connections			Station Connections	
Wire Color	Pair	Pin No.	Clip Term.	Pair	Wire Color	Station	Location
White-Blue	1	26	1	Signal Path	Green	10	
Blue-White		1	2		Red		
White-Orange	2	27	3	Signal Path	Green	11	
Orange-White		2	4		Red		
White-Green	3	28	5	Signal Path	Green	12	
Green-White		3	6		Red		
White-Brown	4	29	7	Signal Path	Green	13	
Brown-White		4	8		Red		
White-Slate	5	30	9	Signal Path	Green	14	
Slate-White		5	10		Red		
Red-Blue	6	31	11	Signal Path	Green	15	
Blue-Red		6	12		Red		
Red-Orange	7	32	13	Signal Path	Green	16	
Orange-Red		7	14		Red		
Red-Green	8	33	15	Signal Path	Green	17	
Green-Red		8	16		Red		
Red-Brown	9	34	17	Signal Path	Green	18	
Brown-Red		9	18		Red		
Red-Slate	10	35	19	Signal Path	Green	19	
Slate-Red		10	20		Red		
Black-Blue	11	36	21	Signal Path	Green	20	
Blue-Black		11	22		Red		
Black-Orange	12	37	23	Signal Path	Green	21	
Orange-Black		12	24		Red		
Black-Green	13	38	25	Signal Path	Green	22	
Green-Black		13	26		Red		
Black-Brown	14	39	27	Signal Path	Green	23	
Brown-Black		14	28		Red		
Black-Slate	15	40	29	Signal Path	Green	24	
Slate-Black		15	30		Red		
Yellow-Blue	16	41	31	Signal Path	Green	25	
Blue-Yellow		16	32		Red		
Yellow-Orange	17	42	33				
Orange-Yellow		17	34				
Yellow-Green	18	43	35				
Green-Yellow		18	36				
Yellow-Brown	19	44	37				
Brown-Yellow		19	38				
Yellow-Slate	20	45	39				
Slate-Yellow		20	40				
Violet-Blue	21	46	41				
Blue-Violet		21	42				
Violet-Orange	22	47	43				
Orange-Violet		22	44				
Violet-Green	23	48	45				Common Audible
Green-Violet		23	46				
Violet-Brown	24	49	47				Station 17 Audible
Brown-Violet		24	48				
Violet-Slate	25	50	49				Power Fail Station
Slate-Violet		25	50				

2.5.6 Connecting Stations To The J1632

The following two tables show the color-coded connections for a J1632 common equipment cabinet.

Connecting Stations To J1 On The J1632 Common Equipment Cabinet

25-Pair Connections				Two-Wire Connections		Station Connections	
Wire Color	Pair	Pin No.	Clip Term.	Pair	Wire Color	Station	Location
White-Blue	1	26	1	Signal Path	Green	10	
Blue-White		1	2		Red		
White-Orange	2	27	3	Signal Path	Green	11	
Orange-White		2	4		Red		
White-Green	3	28	5	Signal Path	Green	12	
Green-White		3	6		Red		
White-Brown	4	29	7	Signal Path	Green	13	
Brown-White		4	8		Red		
White-Slate	5	30	9	Signal Path	Green	14	
Slate-White		5	10		Red		
Red-Blue	6	31	11	Signal Path	Green	15	
Blue-Red		6	12		Red		
Red-Orange	7	32	13	Signal Path	Green	16	
Orange-Red		7	14		Red		
Red-Green	8	33	15	Signal Path	Green	17	
Green-Red		8	16		Red		
Red-Brown	9	34	17	Signal Path	Green	18	
Brown-Red		9	18		Red		
Red-Slate	10	35	19	Signal Path	Green	19	
Slate-Red		10	20		Red		
Black-Blue	11	36	21	Signal Path	Green	20	
Blue-Black		11	22		Red		
Black-Orange	12	37	23	Signal Path	Green	21	
Orange-Black		12	24		Red		
Black-Green	13	38	25	Signal Path	Green	22	
Green-Black		13	26		Red		
Black-Brown	14	39	27	Signal Path	Green	23	
Brown-Black		14	28		Red		
Black-Slate	15	40	29	Signal Path	Green	24	
Slate-Black		15	30		Red		
Yellow-Blue	16	41	31	Signal Path	Green	25	
Blue-Yellow		16	32		Red		
Yellow-Orange	17	42	33				
Orange-Yellow		17	34				
Yellow-Green	18	43	35				
Green-Yellow		18	36				
Yellow-Brown	19	44	37				
Brown-Yellow		19	38				
Yellow-Slate	20	45	39				
Slate-Yellow		20	40				
Violet-Blue	21	46	41				
Blue-Violet		21	42				
Violet-Orange	22	47	43				
Orange-Violet		22	44				
Violet-Green	23	48	45				
Green-Violet		23	46				
Violet-Brown	24	49	47				
Brown-Violet		24	48				
Violet-Slate	25	50	49				
Slate-Violet		25	50				

Connecting Stations To J2 On The J1632 Common Equipment Cabinet

25-Pair Connections			Two-Wire Connections			Station Connections	
Wire Color	Pair	Pin No.	Clip Term.	Pair	Wire Color	Station	Location
White-Blue	1	26	1	Signal Path	Green	26	
Blue-White		1	2		Red		
White-Orange	2	27	3	Signal Path	Green	27	
Orange-White		2	4		Red		
White-Green	3	28	5	Signal Path	Green	28	
Green-White		3	6		Red		
White-Brown	4	29	7	Signal Path	Green	29	
Brown-White		4	8		Red		
White-Slate	5	30	9	Signal Path	Green	30	
Slate-White		5	10		Red		
Red-Blue	6	31	11	Signal Path	Green	31	
Blue-Red		6	12		Red		
Red-Orange	7	32	13	Signal Path	Green	32	
Orange-Red		7	14		Red		
Red-Green	8	33	15	Signal Path	Green	33	
Green-Red		8	16		Red		
Red-Brown	9	34	17	Signal Path	Green	34	
Brown-Red		9	18		Red		
Red-Slate	10	35	19	Signal Path	Green	35	
Slate-Red		10	20		Red		
Black-Blue	11	36	21	Signal Path	Green	36	
Blue-Black		11	22		Red		
Black-Orange	12	37	23	Signal Path	Green	37	
Orange-Black		12	24		Red		
Black-Green	13	38	25	Signal Path	Green	38	
Green-Black		13	26		Red		
Black-Brown	14	39	27	Signal Path	Green	39	
Brown-Black		14	28		Red		
Black-Slate	15	40	29	Signal Path	Green	40	
Slate-Black		15	30		Red		
Yellow-Blue	16	41	31	Signal Path	Green	41	
Blue-Yellow		16	32		Red		
Yellow-Orange	17	42	33				
Orange-Yellow		17	34				
Yellow-Green	18	43	35				
Green-Yellow		18	36				
Yellow-Brown	19	44	37				
Brown-Yellow		19	38				
Yellow-Slate	20	45	39				
Slate-Yellow		20	40				
Violet-Blue	21	46	41				
Blue-Violet		21	42				
Violet-Orange	22	47	43				
Orange-Violet		22	44				
Violet-Green	23	48	45				
Green-Violet		23	46				
Violet-Brown	24	49	47				
Brown-Violet		24	48				
Violet-Slate	25	50	49				
Slate-Violet		25	50				

2.5.7 Wall Mounting The Telephone Stations

The DigiTech (product code 77nnn), *Impact* (product code 8nnnn), and *Impression* (product code 2nnnn) telephones are shipped from the factory configured for desk use. To convert them for wall-mounting, follow the procedures outlined below.

To convert the DigiTech model 77nnn telephones for wall-mounting,

1. Disconnect line cord and handset cord from telephone.
2. Turn telephone over to expose lower housing.

CAUTION

The telephone circuitry is sensitive to static electricity discharge. Be sure that your body and the workplace are properly grounded to avoid any static electricity discharge while you perform step 3.

3. Remove screws that attach lower housing to upper housing. Carefully separate lower and upper housings making sure not to disconnect wiring between them.
4. Rotate lower housing 180 degrees. Do not disturb any internal wiring.
5. Refasten lower housing to upper housing. Make sure no wires are caught between upper and lower housings. Do not over-tighten screws while refastening the housings.
6. Route line cord through appropriate channel on lower housing, and reconnect it to telephone. You may substitute a shorter line cord if you wish.
7. Reconnect the handset cord.

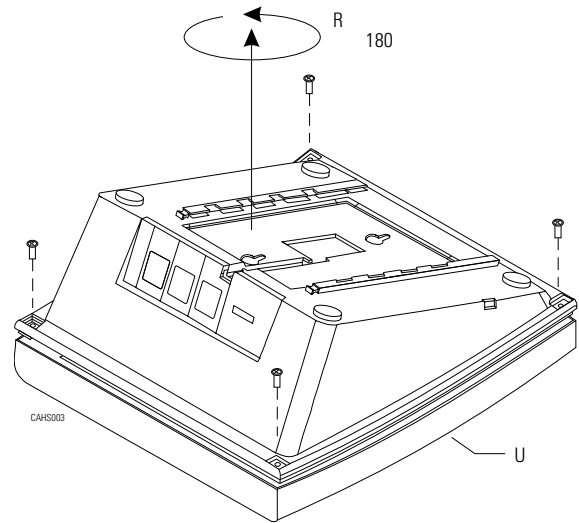

***Rotating The Lower Housing On
Model 77nnn Telephones***

To convert the *Impact* (models 80nnn and 81nnn) and *Impression* (models 20nn and 21nnn) telephones for wall-mounting,

1. Turn telephone over and disconnect line cord and handset cord from telephone. Do not damage line cord on plastic dressing tabs.
2. Remove screws from pedestal and unlatch it from telephone housing, rotate it 180 degrees, re-latch its tabs in the slots in the lower housing of the telephone, and replace screws.
3. Route line cord as appropriate, and reconnect it to telephone. Substitute shorter line cord if desired.
4. This telephone has a reversible handset retaining hook. When wall mounting, pull up this hook and rotate it 180 degrees.
5. Reconnect the handset cord.

There are wall-mounting enhancement kits available through your normal distribution channels. These kits include a handset cradle cup that you can screw-mount to the telephone's upper housing. The product codes for these enhancement kits are: HCCI for the *Impact* telephones (models 80nnn and 81nnn) and *Impression* telephones (models 20nnn and 21nnn), and HCCX for the DigiTech telephones (model 77nnn).

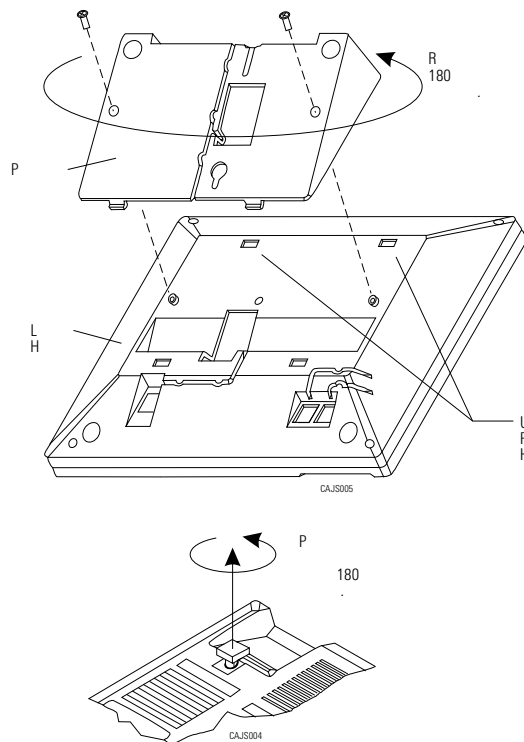

Reversing The Pedestal And Handset Hook
(Model 80nnn, 81nnn, 20nnn and 21nnn Telephones)

To wall-mount the telephones,

After configuring a telephone for wall mounting, either mount it directly on the wall using two #10 pan-head screws (obtained locally), or mount it on a wall jack cover plate. If using a wall jack cover plate, use an AT&T type 630B wall plate for best results.

1. If #10 screws are used, thread them into the wall within 1/8-inch of the surface. Refer to the illustration for the spacing dimensions.
2. Position the keyhole-shaped holes in the bottom of the telephone over the #10 screws or the cover plate studs. Slide the telephone down until a slight click is felt.
3. To remove the telephone, lift to unsnap both screws or studs from the bottom housing, and then lift away from the wall.

Wall Plate - OR - #10 Screws

NOTE: AT&T 630B wall plate is recommended for secure mount.

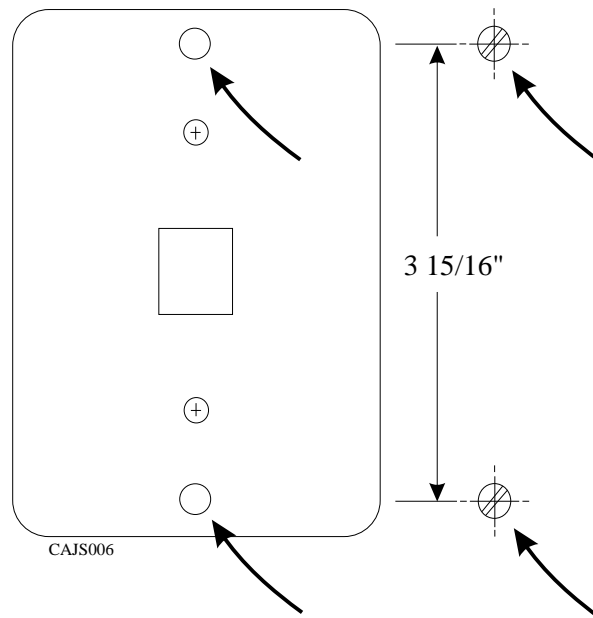

Detailing The Station Wall Mounting

2.6 Installing DSS/BLF Consoles

The digital telephone system supports the installation and use of DigiTech DD32X, *Impact* IB64X, and Impression DU32X consoles at any available station port. The number of installed consoles is limited only by port availability; however, since a console complements a companion telephone located in an adjacent station port, you can use up to one-half of the available station ports for consoles. In addition, with the dual console feature (discussed later), a full two-thirds of the total station port capacity is available for console use.

You can assign two consoles to one telephone, each taking its own station port. This feature is especially useful with DigiTech DD32X and Impression DU32X consoles and a J1632 system that has one or two JM408 expansion modules included with it. This *dual console feature* allows a station user to monitor up to 48 stations from one station location using 32-button consoles.

Install the first console at the station port that is logic-paired with the station that you wish to complement. Install the second console at any station port except 10 or 11 and, using class of service programming, assign it to the same station port that is logic-paired with the first console.

Detailing The Digital Station Port Logic Pairing

10-11	26-27	42-43
12-13	28-29	44-45
14-15	30-31	46-47
16-17	32-33	48-49
18-19	34-35	50-51
20-21	36-37	52-53
22-23	38-39	54-55
24-25	40-41	56-57

You can install the DSS/BLF console at any station port and assign it to a station without first installing a console at the station's logic-paired port if you wish. This configuration is convenient for adding a console to an existing telephone installation that already has its logic-paired port occupied; however, do not use this configuration for assigning a console to station ports 10 and 12 because the console buttons will not be usable for programming. As discussed above, this feature is also useful for adding a second console to a station that already has a paired console installed with it.

The digital telephone system automatically recognizes a console when you connect it to a station port and automatically assigns the station intercom numbers to the console buttons for direct station selection (DSS) purposes with associated busy lamp field (BLF) status lights. However, the console buttons are fully programmable and the station user can customize them as he or she sees fit by programming them as DSS buttons or as automatic dialing (autodial) buttons.

When the user programs the buttons for DSS use, autodial capability is also available at a secondary level at each DSS button.

While the first console (the one installed at the logic-paired port) extends the autodial buttons of the paired telephone by 48 and provides DSS/BLF coverage for station ports 10 through 57, the second console (the one installed at the programmed station port) provides DSS/BLF coverage as follows:

- On a 32-station system with two 8-station expansion modules, the first 16 buttons are automatically assigned (defaulted) to station ports 42 through 57 for DSS purposes.
- On a 32-station system with one 8-station expansion module, the first 8 buttons are automatically assigned (defaulted) to station ports 42 through 49 for DSS purposes.
- On any other smaller station capacity system, all buttons are unassigned.

When you install a console and program it to complement a telephone without first having a console installed at a port that is logic-paired to that telephone, its button assignment is automatically defaulted, as described above, but the user can reprogram it as required. It is important to remember that when you program for a second console, the system sets the console button mapping to that which is described above. When you clear the assignment, the system resets the button mapping to match a logic-paired console. This means that when you clear the second console feature, the console installed at that port complements the telephone that is installed at its logic-paired port instead of the telephone that is located at the program-designated port, and its buttons are automatically reassigned to station ports 10 through 57.

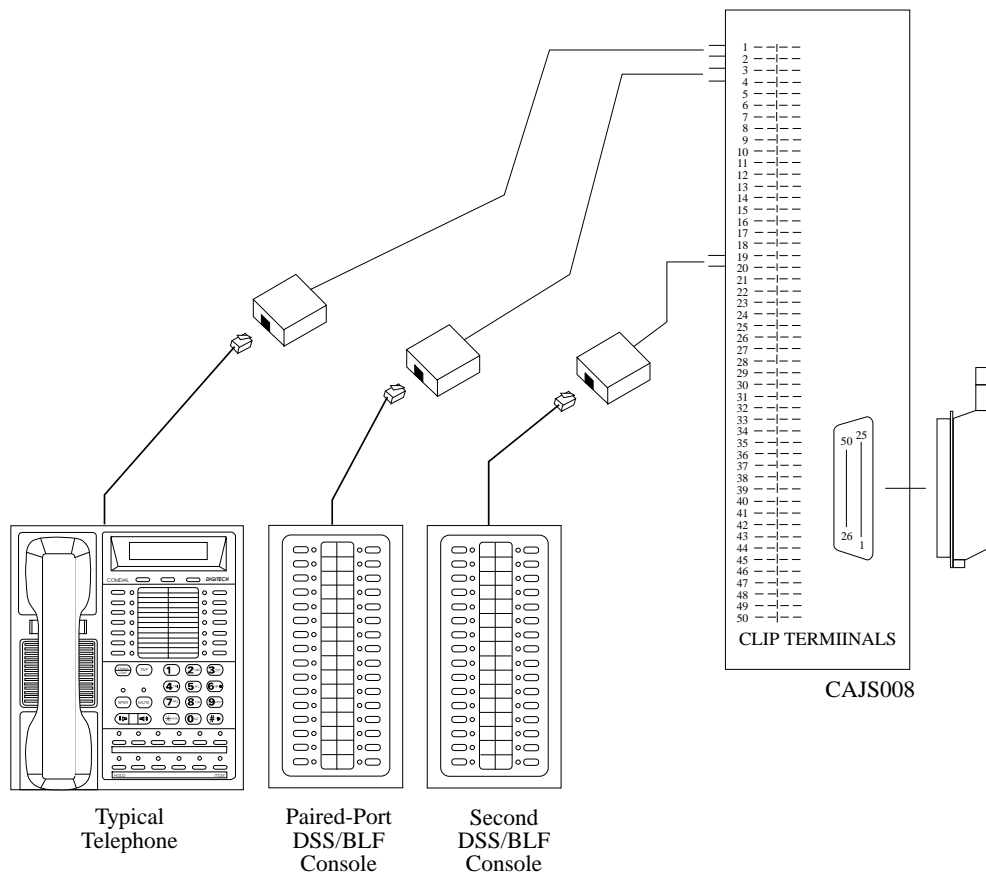

Connecting DSS/BLF Consoles

2.7 Connecting A Power Failure Station

The system provides a tip and ring pair connected to line 1 as an emergency power failure circuit. This circuit is active during a commercial AC power failure if an external battery assembly is not installed to provide battery back-up power to the system. Connect an industry standard, single-line telephone, such as a model 2500, to a power failure pair and use it to provide communications capability until the AC power to the system is restored.

NOTE: *The system also provides one power failure connection with each add-on expansion module.*

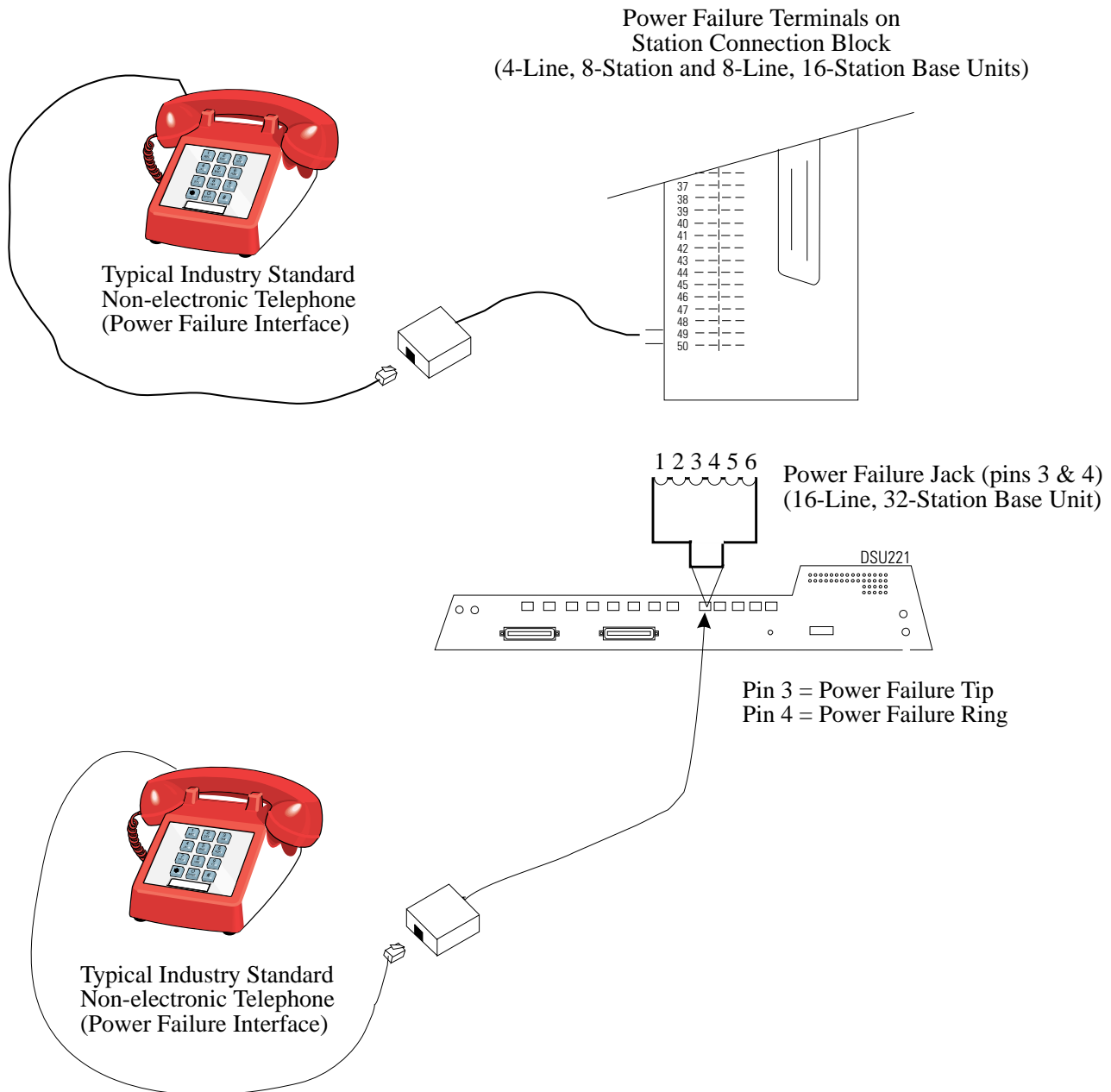

Making A Power Failure Connection

2.8 Using The Auxiliary Equipment Interface

You can connect an industry-standard telephone or a data device such as a modem or a FAX machine on a line ahead of the common equipment if you wish. If you do so, the system can detect an off-hook condition in the connected device and turn on the line status light at the system telephones to indicate that the line is busy.

Connection is across tip and ring of lines 2 and 4. The system provides the auxiliary interface connections at terminals 1 and 6 of common equipment line jacks 1 and 2.

NOTE: When you are employing this auxiliary interface feature, the line-to-line port reassignment feature (Section 2.4.2) works as described except in regard to line 2 and line 4. You can only reassign Line 2 to line port 4 and line 4 to line port 2.

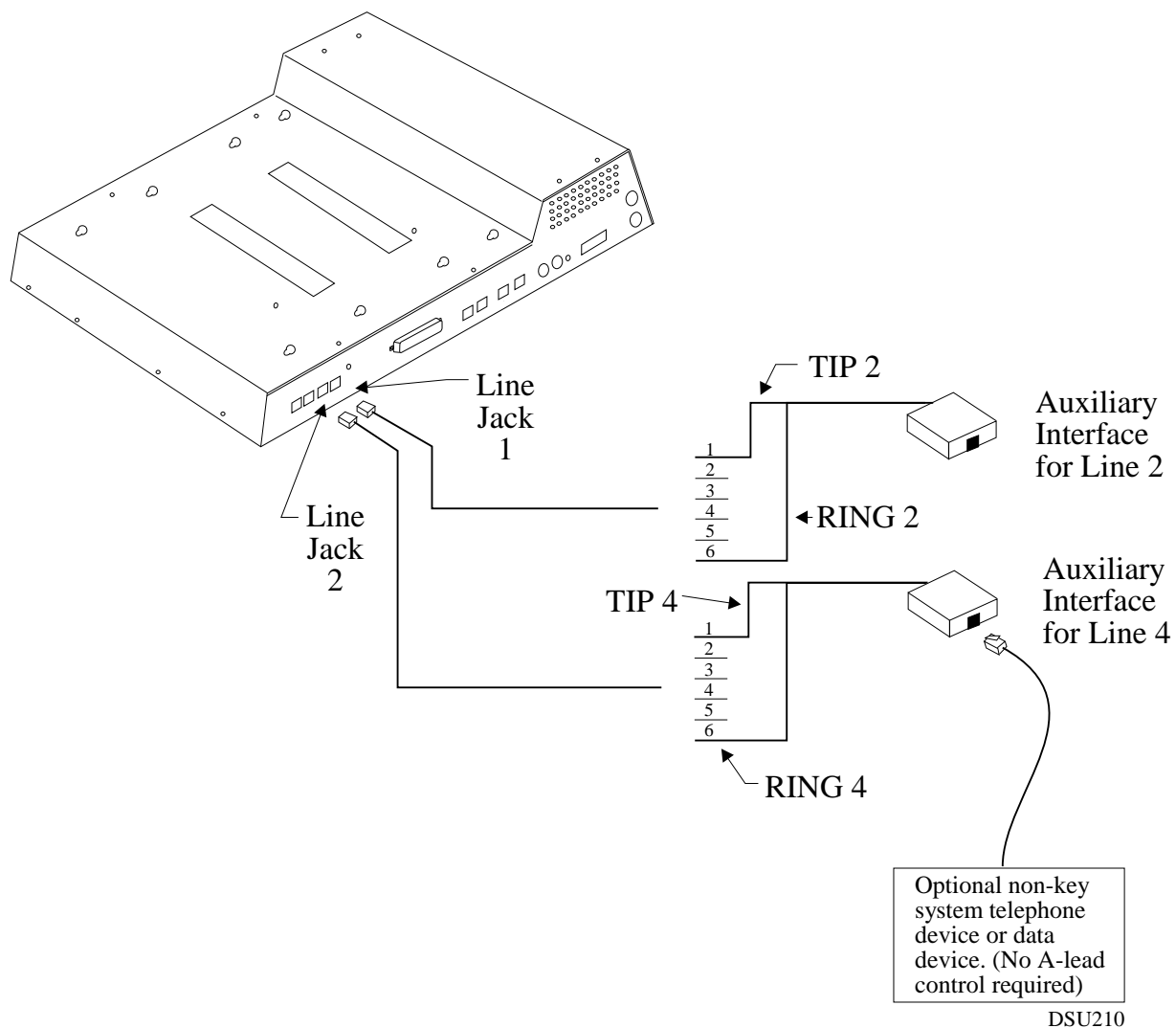

Making The Auxiliary Interface Connections

2.9 Connecting The Common Audible And Auxiliary Ringing Interface

You can use the relay closure dry-contact points for controlling external audible equipment. These contact closures track the pattern of the ringing for incoming calls. The contacts are closed during the ringing period and are open during the silent period.

CAUTION

Do not exceed a 1 amp at 24 volts (0.5 amp at 48 volts) load on these control terminals. If the load requirements exceed this limit, connect the load through an external slave relay. DO NOT CONNECT THESE CONTROL TERMINALS DIRECTLY TO THE 117VAC LINE.

2.9.1 Connecting Outside Lines

Common audible terminals provide a dry-contact closure whenever any of the outside lines that you have connected to the common equipment ring with an incoming call.

2.9.2 Connecting Selected Ports

Station 17 audible terminals provide a dry-contact relay closure whenever ringing is sent to station 17 or to a programmable destination. Use class of service programming to choose either the station 17 or the programmable paging port as the ringing destination. Refer to Chapter 3 for programming details.

When you have programmed for station port 17 ringing, it is a common practice to use a customer-supplied external device to provide loud ringing and connected in a manner similar to the common audible arrangement shown in the illustration on the next page.

CAUTION

Do not connect an external paging device or any external ringing device to station port 17 connections.

When you have programmed for paging port ringing, it is a common practice to use a customer-supplied external paging amplifier connected to the paging port to amplify and broadcast the ringing tones sent to the paging port by the system. You can employ the relay closures that appear at the ringing terminals to energize the external paging amplifier during the periods when the ringing tones are being sent if necessary.

NOTE: *Refer to Section 2.10 for a discussion of external paging amplifier connections and information for using the paging port ringing terminals in an alternate paging enable function.*

(Wiring shown for low current application - see caution text)

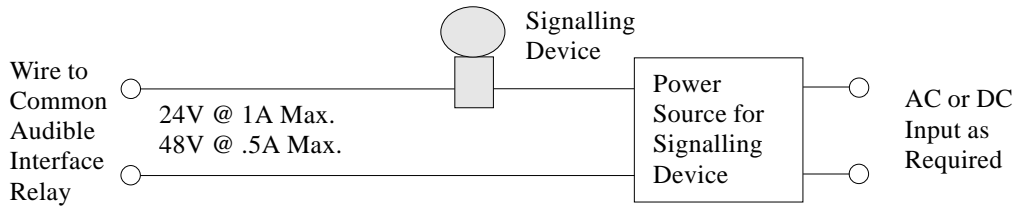

(Wiring shown with slave relay connection for high current application - see caution text)

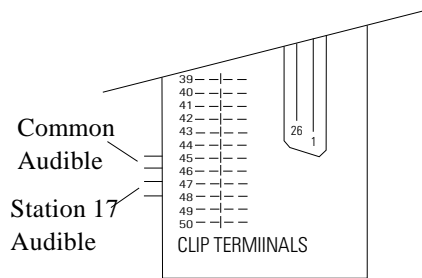
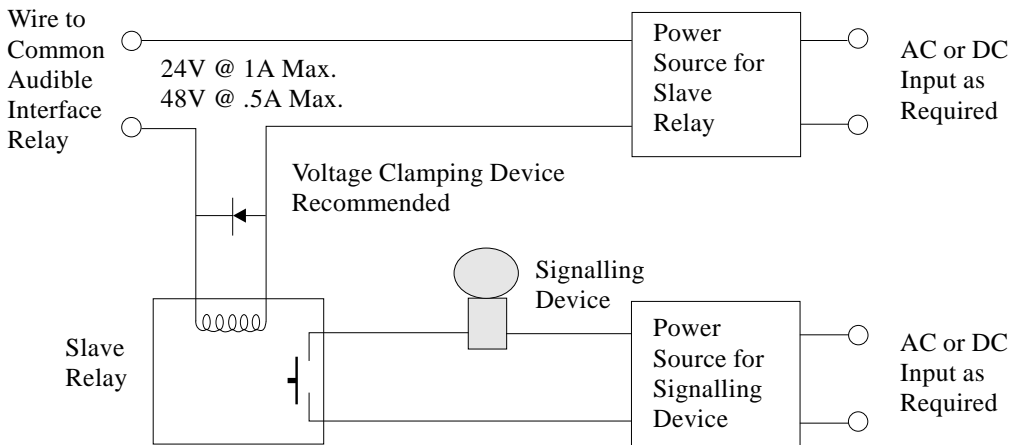

Station Connector Block
(4-Line, 8-Station and
8-Line, 16-Station Base Units)

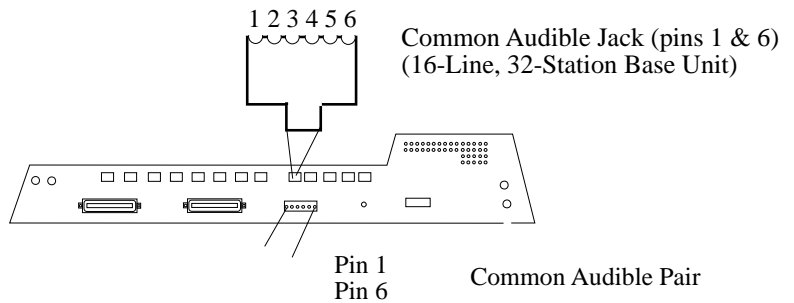

DSU222

Connecting Typical Common Audible Interface Wiring

2.10 Using The External Paging Interface

The system provides a special transformer-isolated paging port that you can use to couple the system to a customer-supplied external paging amplifier. This external paging port does not provide a talk-back path nor will it recognize DTMF dial tones.

You can use the relay closure dry-contact points that the system makes available at the ringing port terminal for controlling the external paging amplifier during a paging operation. These contacts close and stay closed during the time that a paging operation is active to provide a constant enable signal path for the paging amplifier.

NOTE: *This paging enable constant closure function overrides the ring pattern closure provided when ringing is sent to the paging port.*

- Connect the audio input of a customer-supplied external paging amplifier to the paging port.
- If the paging amplifier requires an enable signal, connect the enable leads to the station 17 audible terminals.

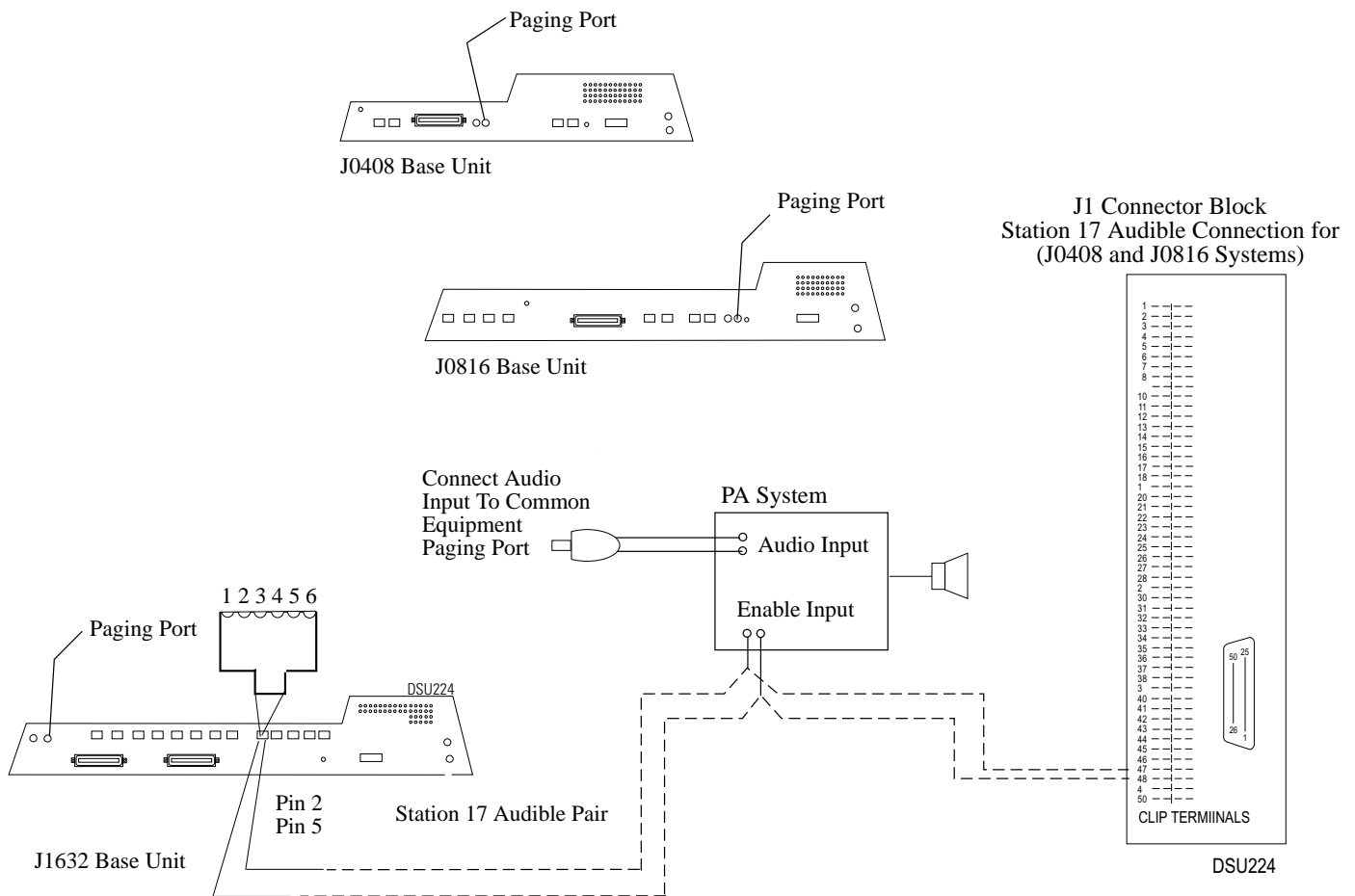

Connecting A Typical External Paging Interface

2.11 Using A Line Port As An External Paging Interface

You can use class of service programming to program a line port to be an AUXILIARY port. As an AUXILIARY port, a user can use it to couple a telephone to an external paging device that you have wired to the line port. He or she does this from any station with that line presence by pressing the proper line button to select the AUXILIARY port. The user can dial DTMF tones or dial pulses through the AUXILIARY port as needed. The paging enable relay closure feature discussed previously is not available for use with this installation.

- Connect the audio input of a customer-supplied external paging amplifier to the tip and ring leads of the AUXILIARY port.
- You can install a DTMF tone select, zone-paging amplifier if you wish. If you do install this type of amplifier, the user must dial the zone-select code after he or she presses the AUXILIARY port line select button.

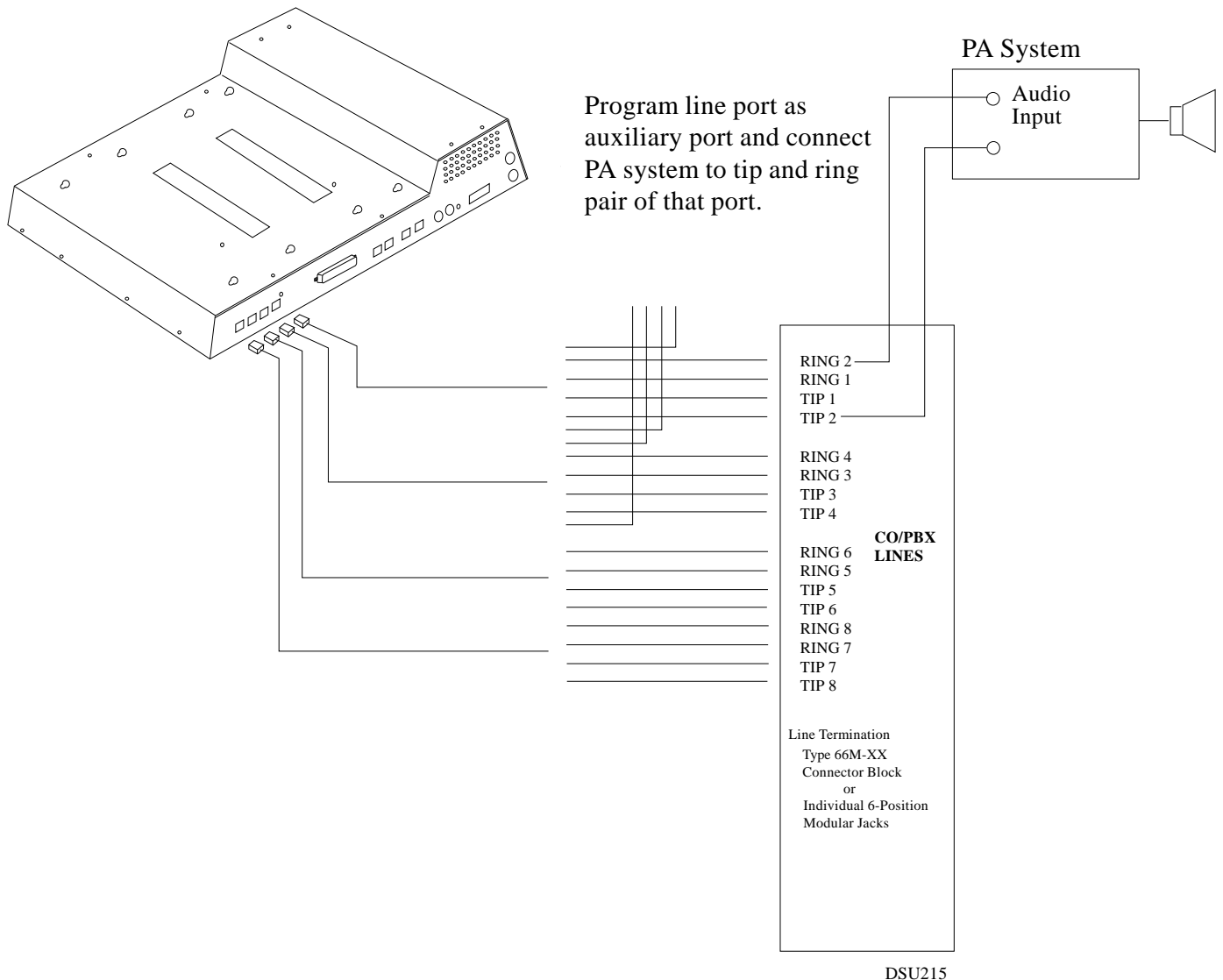

Connecting A Line Port As An External Paging Port

2.12 Connecting Data Devices To The System

The DSU II includes serial data ports for use. The common equipment cabinet provides these ports as standard modular jacks labeled COM 1 and COM 2. This section contains information on two stages of wiring these connections for data devices.

Section 2.12.1 explains connections from stations to modular jacks. Section 2.12.2 details wiring from the modular jack to the DSU.

2.12.1 Making Modular Jack Data Connections

Modular jack connections are wiring connections from a station to a modular (wall) jack.

The system provides two serial data ports on the J0408 and four serial data ports on the J0816 and J1632 for use.

- When you use a personal computer (PC) to perform class of service programming or to load system software into the system, connect it to COM 1.
- When you use a serial data printer for SMDR, SMDA, COS printout, or Caller ID, connect it to the COM 2.

NOTE: The distance between a data device and the common equipment can be up to 500 feet in a quiet electrical environment. Some sites may require shielded cable for long runs. For longer distances, you must install limited distance modems to relay the data communications between the common equipment and a data device.

When preparing a cable for connection to a data device, refer to the manufacturer's manual for the equipment being interfaced and make the following wiring connections:

- Wire the common equipment RD (data from device to common equipment) connection to the device TD (transmit data) connection.
- Wire the common equipment TD (data to device from common equipment) connection to the device RD (receive data) connection.
- Wire the common equipment SG (signal ground) connection to the device SG (signal ground) connection.
- If required for proper operation, wire the common equipment CTS (clear-to-send status from device to common equipment) connection to the device RTS (request-to-send) connection.

NOTE: The common equipment requires a positive voltage, with respect to signal ground, in order to send data.

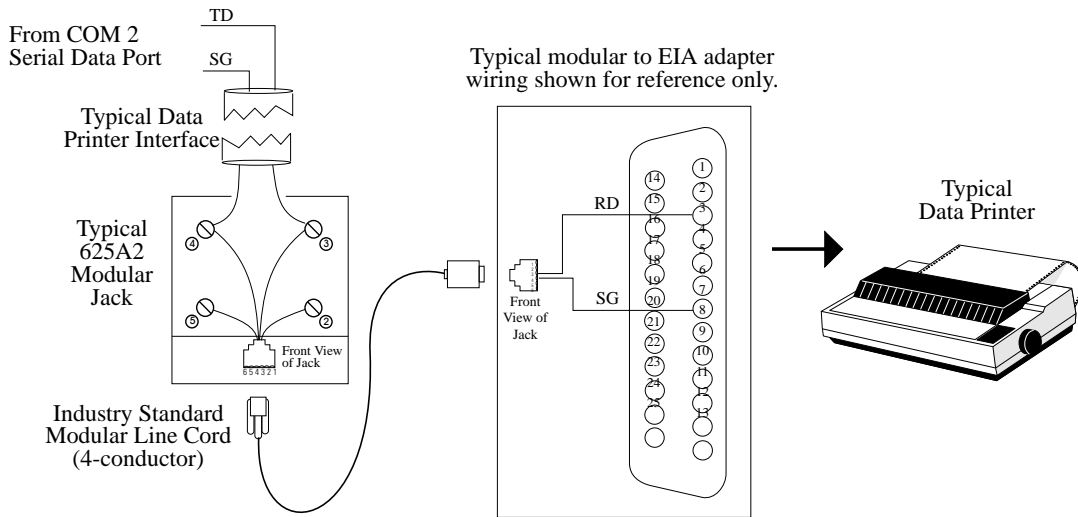
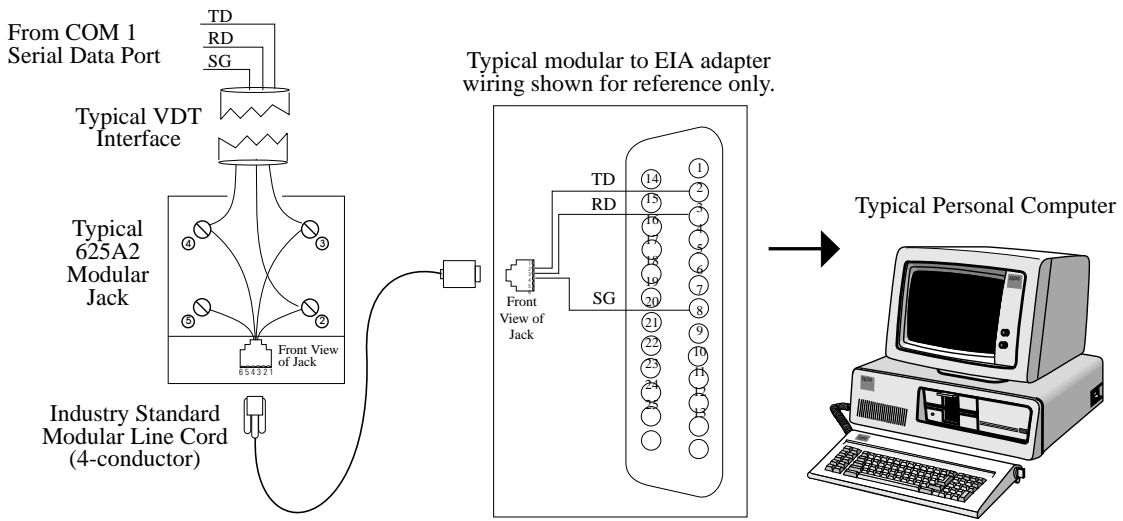

263.

Typical Modular To 9-Pin EIA Adapter
Wiring Shown For Reference Only

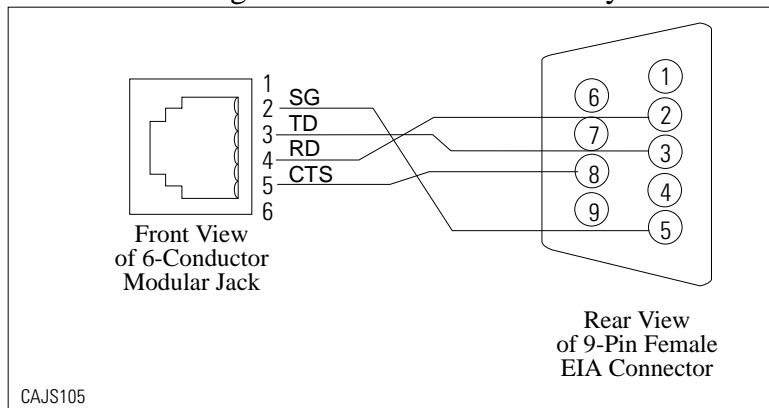

Connecting Data Devices Through Modular Connections

2.12.2 Making The Common Equipment Data Connections

You must make wiring connections from the modular jack (wall jack) to the common equipment cabinet modular jack for the data connection.

The default data communications format is as follows:

- 8-bit data with 1 stop bit and no parity
- Baud rate of 9600 baud.

Configure a data device to match this format for initial operation or reprogram the system's data format to match those of a data device. The tables below list the system's data ports.

NOTE: The distance between a data device and the common equipment can be up to 500 feet in a quiet electrical environment. Some sites may require shielded cable for long runs. For longer distances, you must install limited distance modems to relay the data communications between the common equipment and a data device.

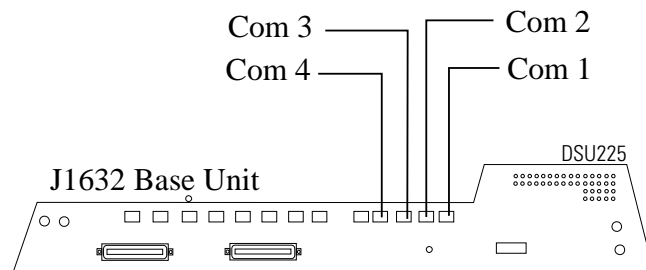
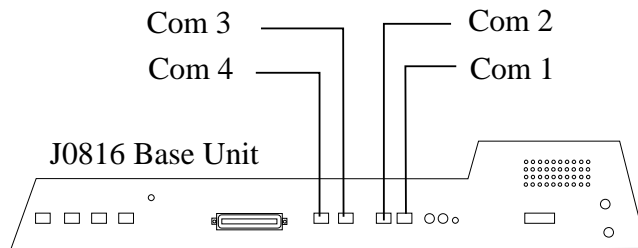
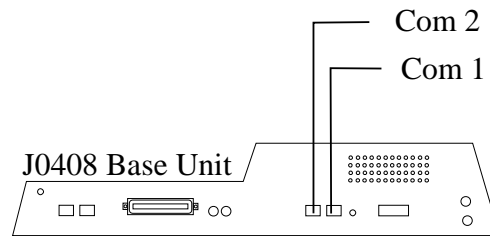

- 1.= Request to Send (RTS)
- 2.= Clear to Send (CTS)
- 3. = Receive Data (RD)
- 4. = Transmit Data (TD)
- 5. = Signal Ground (SG)
- 6. = No Connection

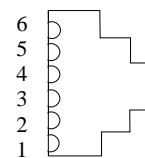

(Front View of Jack)

Making Data Connections To The System

2.12.3 Connecting A Personal Computer For Remote Programming

You can connect a personal computer (PC) to the DSU II digital telephone system remotely through modems as described below. (For information on direct connection, refer to Section 2.12.1.)

You will need the following customer-supplied equipment:

- PC and appropriate software program,
- Pair of data modems.

The data modems must be: “Hayes-compatible,” capable of 300-, 1200-, 2400-, or 9600-baud data speeds, and have auto-answer capability. Be sure to verify the auto-answer capability before purchasing the units. You are assured of best results if you employ modems of the same make and model at both the installation site and the remote programming site.

Make the equipment connections per the following procedure:

1. Determine the signal needs of the modem from the user’s manual for it. (The digital telephone system only requires TD, RD, and SG but the modems may require more signals. Check with the modem manufacturer for special requirements).
2. Wire the proper connector (to match the data jack) on one end of a length of multiline cable.
3. Punch down the appropriate leads on the connector block.
4. Connect the network jack of the data modem to an outside telephone line. (If a line is not reserved for remote programming, have a line switch installed so that on site personnel can switch the outside telephone line between the data modem and the digital telephone system cabinet when you are going to perform remote programming.)
5. Refer to the user’s manual for the modem, and program the modem to automatically answer after the first ring.
6. Interface the PC with the modem at the programming site per the user’s manuals for the equipment be used.
7. Establish a communications link for programming the system from a remote site.
 - If you have had a line switch installed at the customer site, call someone there and ask them to set it for modem operation.
 - After the outside line is connected to the modem, make the data link between the originating and the remote modems, and perform programming from your remote site just as if the PC was connected directly to the system.

If you experience difficulty in establishing a communications path between your PC, modems, and the digital telephone system, note the suggestions that are listed below.

- Confirm that the modems are wired correctly. Be sure RD, TD, and SG are connected to the system's serial data connection. Reverse connections at pins 2 and 3 if necessary. Sometimes you must strap pin 4 to 5, or pin 6 to 7, or pin 6 to 8 to 20 in the modem wiring. Check the modem's installation manual for this requirement. Also check the manual for any additional wiring connections.
- Use a breakout box data tester to troubleshoot the data communications lines.
- Be sure that your modem has: auto-answer capability, DTR override, and CD override and that the Result Codes, On-Line Echo, Off-Line Echo, and Flow Control are disabled. Plus, make sure that you have enabled the modem's auto-answer feature. The way to do this is to program an initialization string into the modem. A typical initialization string that uses generic modem AT Commands for connection to a telephone system's serial data port is as follows: **AT E0 F1 L2 Q1 S0=0 &C0 &D0 &K0 &W0 &Y0**. Remember, this is a typical initialization string—not all modems will respond to it. You should refer to your modem's instruction manual if you have difficulty.

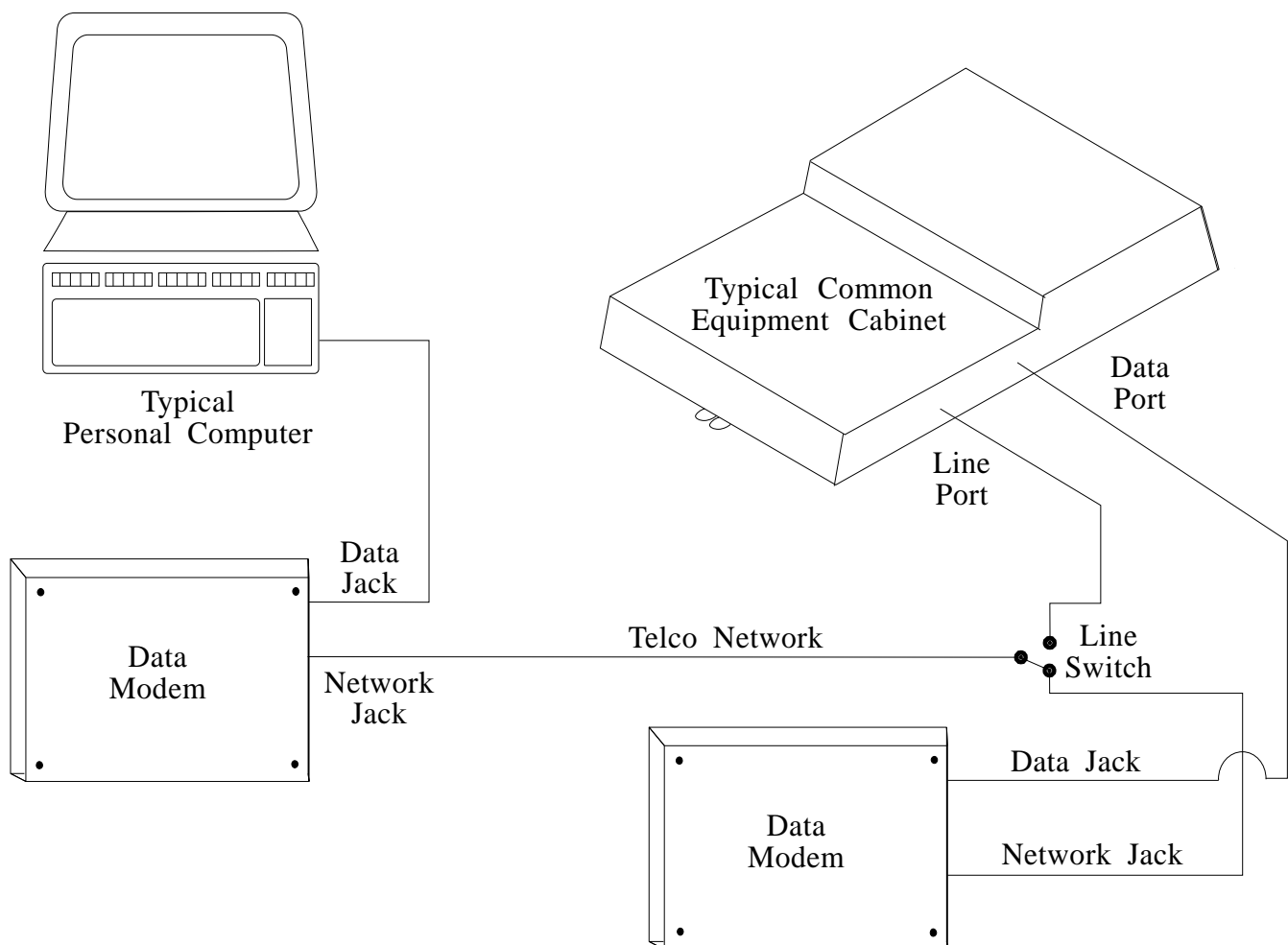

dsu260.cdr

Installing A Personal Computer For Remote Programming

2.13 Using The Music Interface

If music is to be part of the system, connect a customer-provided music source to the common equipment music interface jack (phono jack) provided for this purpose. The impedance of this input is approximately 500Ω. Use the volume control on the music source to adjust the audio level of the music as required.

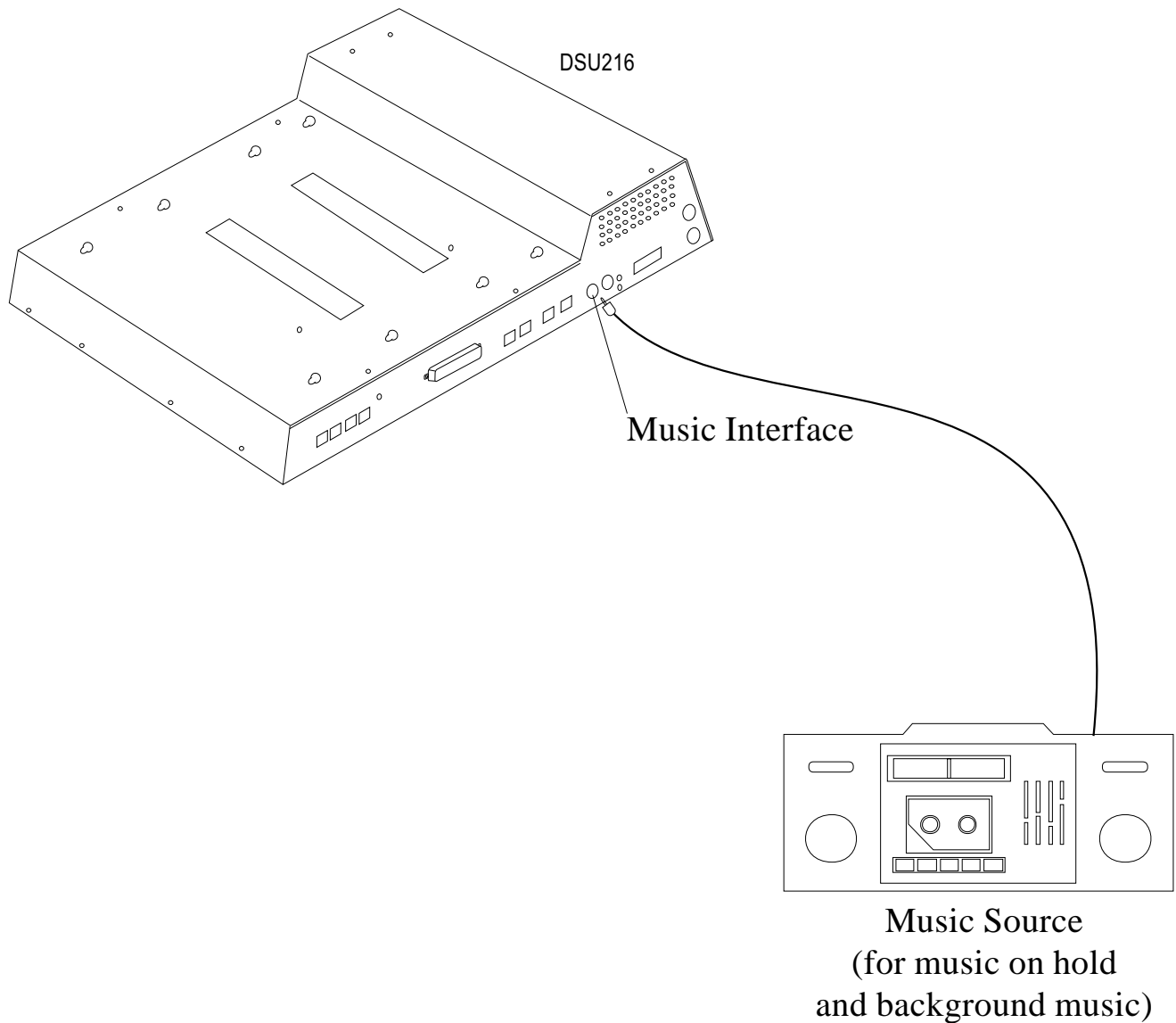

Using The Music Interface

2.14 Using The Add-On Expansion Modules

You can install optional add-on expansion modules to the DSU II common equipment base unit to increase the line and station capacity of an installed system.

- The JM408 expansion module provides an additional four lines and eight digital proprietary stations.
- The JM008 expansion module provides interface and ring generation for eight industry-standard telephone devices.

Base Unit Type	Base Unit Capacity		Expansion Module Type	Total System Capacity		
	Lines	System Stations		Lines	System Stations	ISTs
J0408	4	8	one JM408	8	16	-
			one JM008	4	8	8
J0816	8	16	one JM408	12	24	-
			two JM408	16	32	-
			one JM008	8	16	8
			two JM008	8	16	16
			one JM408 and one JM008	12	24	8
J1632	16	32	one JM408	20	40	-
			two JM408	24	48	-
			one JM008	16	32	8
			two JM008	16	32	16
			one JM408 and one Jm008	20	40	8

2.14.1 Using The JM408 Module

The JM408 expansion module provides to an installed system an additional four lines and eight digital proprietary stations. The default numbering of the expanded lines and stations begin with the next higher line or station port number from that provided by the host base unit. The numbering continues sequentially from top module to bottom module if two modules are installed. For example: The defaulted 8-line, 16-station base unit provides station ports 10 through 25 and lines 1 through 8. When installed, a JM408 expansion module provides station ports 26 through 33 and lines 9 through 12 thus creating a 12 line by 24 station system.

Each expansion module provides a tip and ring pair as an emergency power failure circuit. This circuit is connected to the first module-provided line.

Connecting Lines To The JM408 Expansion Module

The expansion module's line connections are available at two modular jacks. When facing the jack openings, lines 1 and 2 are provided by the jack on the right and lines 3 and 4 are provided by the jack on the left.

Line Jack	Pin Number	Connection	Telephone Number
1	1	No Connection	
	2	Line 2M Tip	
	3	Line 1M Tip	
	4	Line 1MRing	
	5	Line 2M Ring	
	6	No Connection	
2	1	No Connection	
	2	Line 4M Tip	
	3	Line 3M Tip	
	4	Line 3M Ring	
	5	Line 4M Ring	
	6	No Connection	

Connecting Stations To The JM408 Expansion Module

The station connections are available at a 50-pin connector.

25-Pair Connections				Two-Wire Connections		Station Connections	
Wire Color	Pair	Pin No.	Clip Term.	Pair	Wire Color	Station	Location
White-Blue	1	26	1	Signal Path	Green	1M	
Blue-White		1	2		Red		
White-Orange	2	27	3	Signal Path	Green	2M	
Orange-White		2	4		Red		
White-Green	3	28	5	Signal Path	Green	3M	
Green-White		3	6		Red		
White-Brown	4	29	7	Signal Path	Green	4M	
Brown-White		4	8		Red		
White-Slate	5	30	9	Signal Path	Green	5M	
Slate-White		5	10		Red		
Red-Blue	6	31	11	Signal Path	Green	6M	
Blue-Red		6	12		Red		
Red-Orange	7	32	13	Signal Path	Green	7M	
Orange-Red		7	14		Red		
Red-Green	8	33	15	Signal Path	Green	8M	
Green-Red		8	16		Red		
Red-Brown	9	34	17				
Brown-Red		9	18				
Red-Slate	10	35	19				
Slate-Red		10	20				
Black-Blue	11	36	21				
Blue-Black		11	22				
Black-Orange	12	37	23				
Orange-Black		12	24				
Black-Green	13	38	25				
Green-Black		13	26				
Black-Brown	14	39	27				
Brown-Black		14	28				
Black-Slate	15	40	29				
Slate-Black		15	30				
Yellow-Blue	16	41	31				
Blue-Yellow		16	32				
Yellow-Orange	17	42	33				
Orange-Yellow		17	34				
Yellow-Green	18	43	35				
Green-Yellow		18	36				
Yellow-Brown	19	44	37				
Brown-Yellow		19	38				
Yellow-Slate	20	45	39				
Slate-Yellow		20	40				
Violet-Blue	21	46	41				
Blue-Violet		21	42				
Violet-Orange	22	47	43				
Orange-Violet		22	44				
Violet-Green	23	48	45				
Green-Violet		23	46				
Violet-Brown	24	49	47				
Brown-Violet		24	48				
Violet-Slate	25	50	49	Signal Path	Tip	Power Fail Station	
Slate-Violet		25	50		Ring		

Spare Pair

2.14.2 Using The JM008 Module

The JM008 expansion module provides an interface for a wide variety of industry-standard telephone (IST) equipment such as 500 and 2500-type telephones, cordless telephones, voice mail systems, answering machines, FAX machines, and data modems.

Each IST port drives a load with a maximum ringer equivalence number (REN) of 2.0. Check the REN number of the connected IST equipment so you do not exceed the capacity of the IST port. Improper operation may result if you exceed the REN maximum.

The default numbering of the expansion module stations begin with the next higher station port number from that provided by the host base unit. The numbering continues sequentially from top module to bottom module if two modules are installed. For example: The defaulted 8-line, 16-station base unit provides station ports 10 through 25. When installed, a JM008 expansion module provides station ports 26 through 33. A second JM008, when installed in the bottom mounting location, provides station ports 34 through 41.

CAUTION

If you install both a JM408 and a JM008 on the same cabinet, you must install the JM408 at the upper expansion module location or the lines provided by the JM408 will not function.

When you install the JM008 and connect IST devices to it, there are several programming requirements that you must consider. Refer to Chapter 3, Section 3.10 for complete details.

Connecting Stations To The JM008 Module

The station connections are available at a 50-pin connector.

25-Pair Connections				Two-Wire Connections		Station Connections	
Wire Color	Pair	Pin No.	Clip Term.	Pair	Connection	Station	Location
White-Blue	1	26	1	Signal Path	Tip	1M	
Blue-White		1	2		Ring		
White-Orange	2	27	3	Signal Path	Tip	2M	
Orange-White		2	4		Ring		
White-Green	3	28	5	Signal Path	Tip	3M	
Green-White		3	6		Ring		
White-Brown	4	29	7	Signal Path	Tip	4M	
Brown-White		4	8		Ring		
White-Slate	5	30	9	Signal Path	Tip	5M	
Slate-White		5	10		Ring		
Red-Blue	6	31	11	Signal Path	Tip	6M	
Blue-Red		6	12		Ring		
Red-Orange	7	32	13	Signal Path	Tip	7M	
Orange-Red		7	14		Ring		
Red-Green	8	33	15	Signal Path	Tip	8M	
Green-Red		8	16		Ring		
Red-Brown	9	34	17				
Brown-Red		9	18				
Red-Slate	10	35	19				
Slate-Red		10	20				
Black-Blue	11	36	21				
Blue-Black		11	22				
Black-Orange	12	37	23				
Orange-Black		12	24				
Black-Green	13	38	25				
Green-Black		13	26				
Black-Brown	14	39	27				
Brown-Black		14	28				
Black-Slate	15	40	29				
Slate-Black		15	30				
Yellow-Blue	16	41	31				
Blue-Yellow		16	32				
Yellow-Orange	17	42	33				
Orange-Yellow		17	34				
Yellow-Green	18	43	35				
Green-Yellow		18	36				
Yellow-Brown	19	44	37				
Brown-Yellow		19	38				
Yellow-Slate	20	45	39				
Slate-Yellow		20	40				
Violet-Blue	21	46	41				
Blue-Violet		21	42				
Violet-Orange	22	47	43				
Orange-Violet		22	44				
Violet-Green	23	48	45				
Green-Violet		23	46				
Violet-Brown	24	49	47				
Brown-Violet		24	48				
Violet-Slate	25	50	49				
Slate-Violet		25	50				

Spare Pairs

Checking Industry-Standard Telephone Connections To The JM008 Module

When you connect industry-standard telephones to the JM008 expansion module, the maximum distance allowed from the common equipment to the telephone is 1500 feet if you use #24 gauge or larger, twisted pair cable.

Check the installation of industry-standard telephones for proper operation by performing the following voltage measurements under the conditions listed:

- have both the common equipment and the stations connected to the station connector block,
- have bridging clips installed on the connector block,
- have the system powered and operational.

Measure DC voltage across the tip and ring pair of each installed industry-standard telephone with a DC voltmeter. You should read: **+24 volts DC +/- 2 volts.**

Call each industry-standard telephone to stimulate the ring generator assembly, and measure the AC ringing voltage across the tip and ring pair of each called telephone.

You should read: **55 volts AC +/- 5 volts.**

If your measured voltages are different from the values shown herein, it could indicate a wiring error or equipment problem.

Installing An OPX Long Loop Adapter With The JM008

You must use an OPX long loop adapter if you wish to adapt the JM008's IST station port to support an off-premise IST application. An OPX long loop adapter connects to a single telephone line and can greatly extend the line's loop length (the Proctor Model 46222 adapter*, for example, can extend line length to 30,000 feet).

*Proctor & Associates Company, Redmond WA

CAUTION

When you connect an OPX long loop adapter to an off-premise extension (OPX), you must install primary protectors in series with the tip/ring pair of the telephone line that is routed to the OPX. This action is necessary to protect both the user and the equipment from transient voltage spikes that can travel through the cable. The telephone company offers basic protection against this condition; however, that protection is usually designed to safeguard the central office circuits and you cannot rely upon it to protect common equipment. To help insure that external over-voltage surges do not damage the system, installation specialists recommend that you install and properly ground gas discharge tubes or similar primary protection devices on the telephone line that routes between the adapter and the OPX.

To install the OPX long loop adapter:

- Follow manufacturer's instructions for unpacking, inspecting, mounting and wiring the adapter unit.
- Plug a modular cable into the system jack on the adapter and connect the opposite end of the cable to the JM008's station port.
- Plug a modular cord into the telephone jack on the adapter and connect the opposite end of the cord to the OPX line.
- Plug the adapter power cord into a standard 117 VAC, 3-wire electrical outlet.

2.14.3 Installing An Add-On Expansion Module

Each JM408 or JM008 add-on expansion module measures 15.5" wide x 9.4" high x 1.6" wide and weighs approximately 4 pounds. The modules are designed so that you can attach them to the base unit and connect them to it via cabling.

NOTE: *If you plan to upgrade the system software at the same time that you add expansion modules, add the expansion modules first by following steps 1 through 11. Then, after you have installed the expansion modules and programmed for the new stations and line ports, upgrade the software as described in the discussion titled, **Loading And Up-Grading The System Software.***

To install an expansion module to a base unit, follow the procedure detailed in steps 1–11.

CAUTION

You must always connect the first module to the top location on the base unit.

1. Disconnect both AC power and external battery back-up power from the system.
2. Remove and set aside nameplate from base unit. This action exposes internal cable connector on base unit circuit board.
3. Reach through opening in base unit and mate module cable plug with base unit circuit board connectors.
4. Push excess cable inside base unit housing through connector opening.
5. Install expansion module in place on all four mounting holes. Be sure excess cable is not pinched between add-on module and base unit.
6. Pull module down to latch in place.
7. Use appropriate screw driver to tighten module securing screw into base unit threaded fastener.
8. Snap nameplate into slots on top of module housing.
9. Attach #10 or #12 insulated, solid copper wire between the frame ground stud on the expansion module and the frame ground stud on the common equipment cabinet.
10. Reconnect the power to the system.
11. Refer to Chapter 3, and perform configuration programming for new station and line ports.

Typical Base Unit
(8-Line, 16-Station Base Unit)

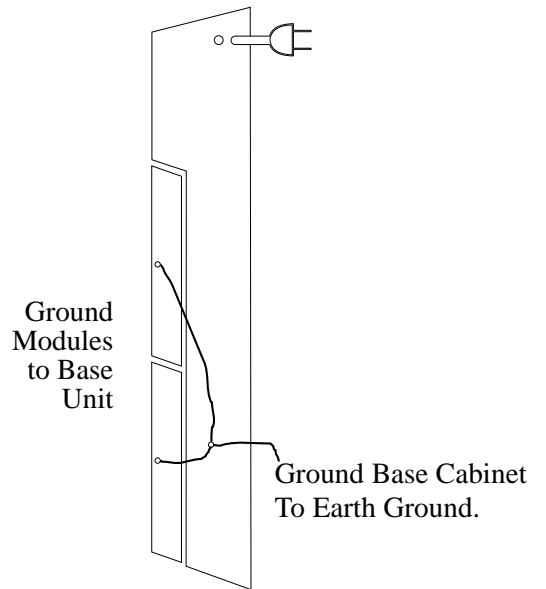
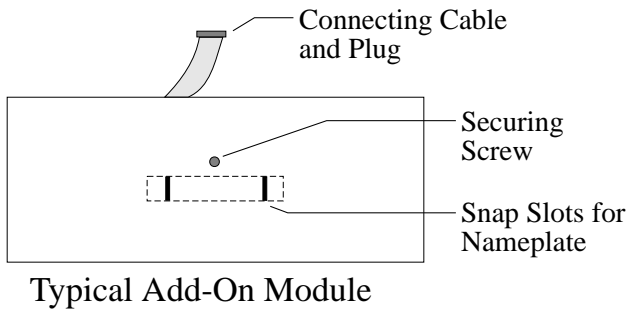
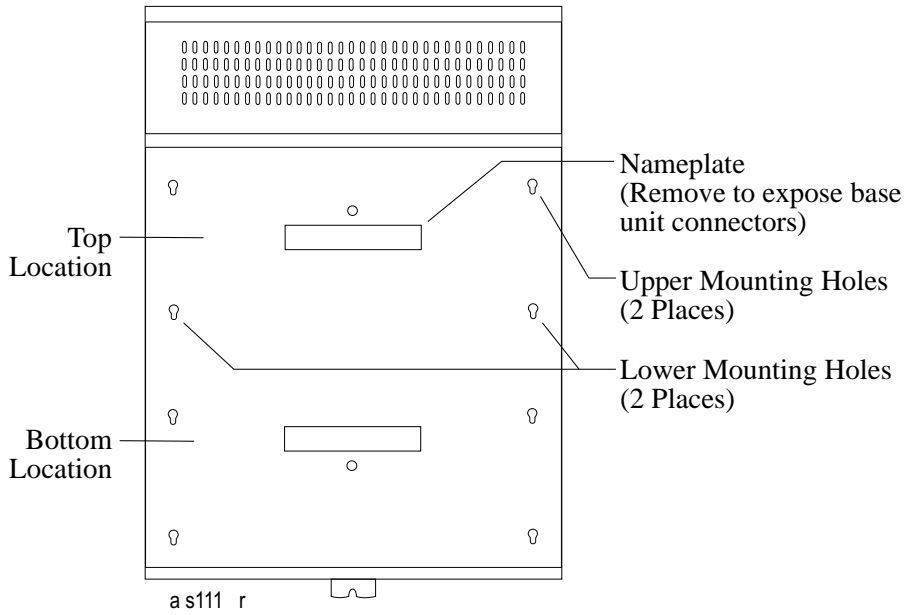

Installing The Add-On Expansion Module

2.15 Checking The System Installation

The system operating features are set to default conditions at initial power-up. These conditions provide a basic operating system with a known set of parameters, and you should check out the system with the default conditions in place. At any time while the system is operating, you can reset default conditions from station port 10 or 12 following the instructions provided in chapter 3, *Programming*.

2.15.1 Checking The Resistance

Measure the resistance at the station connector blocks under the following conditions.

- AC power cord disconnected from electrical outlet.
- Common equipment connected to station connector blocks.
- Stations wired and wiring punched down on blocks.
- Bridging clips removed from blocks to isolate stations from common equipment.

Measure the resistance of each installed station and wiring from the station side of the connector blocks. Resistance values will vary with cable length and station type but should be within the following limits:

- Greater than 700 K Ω

2.15.2 Checking The Voltage

Make the following voltage measurements at the station connector blocks under the following conditions:

- Bridging clips installed
- AC power connected to the common equipment

Measure the voltage across the signal pair. The measured voltage for proprietary telephones must be within the following limits:

- 28–36 VDC

NOTE: *Refer to Section 2.14.2 for information on testing industry-standard telephones connected through the JM008 expansion module.*

2.15.3 Checking The General Operating Conditions

1. Check the green light emitting diode (LED) system status indicator. Be sure that it is on steady. If it is off or flashing, refer to the paragraph titled *Checking the System Status Indicator*.
2. Refer to the user's guide for operating information and perform a general operational test of the system by exercising the features from station port 10 or 11. Operational parameters are per the system default conditions as detailed in Chapter 4 until class of service programming is performed.
3. Once the basic system is verified as operational, perform the class of service programming as described in Chapter 3.

2.16 Isolating Failures

Section 2.17 will help you to find and identify problems that might occur in the digital telephone system.

2.16.1 Checking The System Status Indicator

A green LED located on the common equipment cabinet is the system status indicator. This indicator light comes on when power is supplied to the system. If the indicator flashes after power up, it signals that the processor has failed or that the software is not operating. Unplug and reconnect the AC power to the power supply and observe the LED indication. If it still shows a flashing indication, equipment replacement may be necessary.

2.16.2 Testing The Stations

To test the multiline stations for proper operation:

1. Disconnect line cord at station base then reconnect it.
2. On DigiTech telephones, press and hold the **MUTE** button.
On *Impact* and *Impression* telephones, press and hold **1** on the keypad.
Station will automatically perform self test routine.
3. Release test button as soon as test begins. Sequence of test is as follows:
 - a. indicators will light in sequence,
 - b. ringer will sound—be sure volume is set to low or high,
 - c. indicators and ringer will then turn off at the same time.
4. Replace any station that does not pass the self test.

2.17 Loading And Up-Grading The System Software

The DSU II contains flash memory that you load with operating software when you install the system and later re-load with software up-grades as they become available.

The operating software package consists of three parts: The boot-loader EPROMs that is factory-installed as part of the system, and the software key and software disks that you order separately. The software disks include the boot loader interface disk and the operating software disks.

2.17.1 Introducing The Software Key

The software key is a hardware device to un-lock the DSU II so it can accept the system operating software. Factory technicians program and initialize the software key, and make it available in several different configurations.

The configurations are as listed below:

DSUII-SW01

DSUII-SW05

DSUII-SW10

DSUII-SW25

The configurations control the number of times that you can use a key to load or up-grade operating software into a system; however, it does not matter which DSU II system you load. (For example, with a DSUII-SW01 key, you can load any DSU II system one time; however, with the DSUII-SW25, you can load or up-grade one system 25 times or load 25 different systems one time—your choice.)

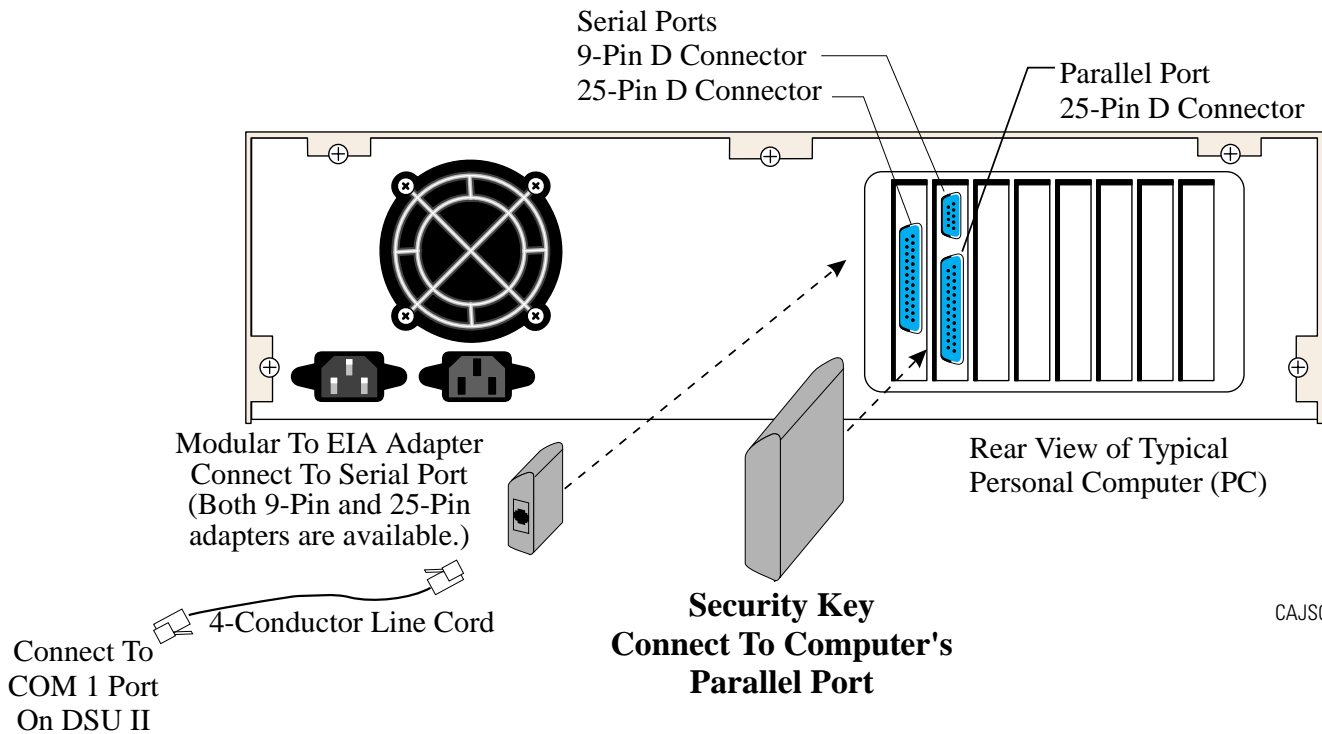

Connecting The Security Key

2.17.2 Introducing The Software Disks

There are several standard 3.5-inch magnetic diskettes for each software part number. This group of diskettes include the boot loader interface and the system operating software. You place these diskettes (commonly referred to as floppy disks), into your personal computer (PC) in a certain order just as you would any set of program disks.

CAUTION

The system operating software is unique for each of the three system sizes. Be sure that you load the correct system software for the size system that you are installing.

2.17.3 Loading The Software

Installing The Bootloader Interface

You must install the boot loader interface on your PC before you can install the system operating software.

Installing The Bootloader Interface Software With Windows 95*

1. Insert the bootloader interface disk (labeled *disk1*) in your PC's disk drive.
2. From the **Start** menu, select **Run**.
3. At the prompt line, type: `<drive>:\disk1\setup` where `<drive>` is the letter of your source disk drive.
4. Click **Ok**. The Bootloader Interface installation window appears.

NOTE: Alternately, you can use the Explorer View to navigate to the source <drive> and then to the disk1 folder. Once there, double click on setup.exe and the Bootloader Interface installation window appears.

5. Remove the bootloader interface disk from you computer's disk drive.
6. From the Bootloader Interface load window, follow the on-screen prompts to finish loading the software. The installation creates a DSU II BTLDR I/F window complete with appropriate icons.

NOTE: Your PC's screen may now show the DSU II BTLDR I/F folder; however, if it does not: select Start, then select Programs, and then navigate to DSU II BTLDR I/F folder.

7. From the DSU II BTLDR I/F window, double click on the **Install SKey Driver** icon.
8. Select **Express** and follow the on-screen prompts.
9. When you reach the prompt to restart windows, do so.

*Windows 95 is a registered trademark of Microsoft Corporation, Redmond, Washington

Installing The Bootloader Interface Software With Windows 3.1* Or Windows For Workgroups 3.11*

1. Insert the bootloader interface disk (labeled *disk1*) in your PC's disk drive.
2. From the **File Manager** menu, select **Run**.
3. At the prompt line, type: `<drive>:\disk1\setup` where `<drive>` is the letter of your source disk drive.
4. Click **Yes**. The Bootloader Interface installation window appears.

***NOTE:** Alternately, you can use the File Manager to navigate through its tree view to the source <drive> and then to the disk1 folder. Once there, double click on setup.exe and the Boot loader Interface installation window appears.*

5. Remove the boot loader interface disk from you computer's disk drive.
6. From the Boot loader Interface load window, follow the on-screen prompts to finish loading the software. The installation creates a DSU II BTLDR I/F folder complete with appropriate icons.

***NOTE:** Your PC's screen may now show the DSU II BTLDR I/F folder; however, if it does not: use the program manager to navigate to DSU II BTLDR I/F group.*

7. From the DSU II BTLDR I/F window, double click on the **Install SKey Driver** icon.
8. Select **Express** and follow the on-screen menu prompts.
9. When you reach the prompt to restart windows, do so.

**Windows 3.1 and Windows For Workgroups 3.11 are registered trademarks of Microsoft Corporation, Redmond, Washington*

Un-installing The Bootloader Interface

The software provides a means by which you can un-install it if you wish.

For Windows 95 operating systems,

1. From the **Start** menu, select **Programs**, and navigate to the DSU II BTLDR I/F folder.
2. Double click on the **Unstall** icon.
3. In the event that you were accessing the DSU II BTLDR I/F folder and its contents, you may need to manually delete the folder and its contents. From Explorer view, navigate through <drive> to **WINDOWS**, then to **START-MENU**, then to **PROGRAMS**, and finally to **DSU II BTLDR I/F**. From there, delete all short-cuts associated with the bootloader interface.

For Windows 3.1 and Windows For Workgroups 3.11,

From the **Program Manager**, navigate to **DSU II BTLDR I/F**, and double click the **Uninstall** icon.

Installing The System Operating Software

CAUTION

In this software loading sequence, the system will prompt you to save the class of service data base. ALWAYS SAVE THE DATA BASE FIRST before you proceed with the software load. Saving the data base first ensures that you will have it available should something go wrong during the software loading procedure. Later, after you have finished loading the system software, master clear the system and reload the data base that you saved before you loaded the software.

Saving The Class Of Service Data Base (Using An XMODEM-Type Communications Program)

Use the PC and an XMODEM-type communications software program to save the DSU II system's class of service data base before you load the software. The following procedure illustrates a typical data base down-load using *PROCOMM* (produced by Datastorm Technologies Inc.). Other software programs are also available that you can use for this purpose.

1. When the PC display prompts for a password, type **I*746*** or the current system password and press **RETURN** (This causes main COS programming menu to be displayed).
2. From main menu, make all selections necessary to perform class of service programming then return to the main menu.
3. From main menu, press **1** and **RETURN** (This causes system COS programming menu to be displayed).

4. From the system menu, press **4** and **RETURN** (This causes load/save menu to be displayed.) From load/save menu, you can down-load the COS data base to your PC (usually to some temporary location on your hard drive).

To down-load the data base,

- (a) press **1** and **RETURN**,
- (b) press **PAGE DOWN**,
- (c) press **1** to choose XMODEM protocol,
- (d) type destination file name for the down-loaded data base—include destination drive (for example, C:\ cust.001)
- (e) press **RETURN**. The data base automatically down-loads to the destination file.

To down-load speed dials and auto dials,

- (a) press **3** and **RETURN**,
- (b) repeat above steps b–e.

To up-load the data base after you have up-graded the system operation software and master-cleared the system,

- (a) press **2** then **RETURN**
- (b) press **PAGE UP**
- (c) press **1** to choose XMODEM protocol
- (e) type file name of saved COS data—include source drive if necessary
- (f) press **RETURN**. The data base is automatically up-loads to the DSU II system.

To up-load speed dials and auto dials,

- (a) press **4** and **RETURN**,
- (b) repeat above steps b–f.

If the up-load completes properly, the screen displays: *Xmodem transfer complete, no errors.*

5. Return to the main menu and log off.

Loading The System Operating Software (Using The DSU II Bootloader Interface)

1. Connect the security key to the parallel port on the PC.

***NOTE:** If you wish to view the available up-grade count and the system type supported by the security key, select **Key** from the main menu and then select **View**.*

2. Install the system operating software disk (labeled *disk2*) in your PC's disk drive. (Alternately, you could have pre-loaded the disk's contents into a file location on your PC's hard drive.)
3. With Windows 3.1 click the boot loader icon to open the DSU II BTLDR I/F window and from there click the **Boot loader Interface** icon.
With Windows 95, select **Start, Programs, DSU II BTLDR I/F, and DSU II Boot loader Interface**. The DSU II Boot loader Interface window will open.
4. From the **DSU II Boot loader Interface** window, select the **System** drop-down menu, and then select **Upgrade**.
5. Follow the on-screen prompts until you reach the Logon Dialog window.
6. At the Logon Dialog window, select the appropriate user type, and type **I*746*** or your current system programming password.
7. Follow the on-screen prompts until you reach the appropriate DSU II System Binary File Selection Dialog box.
8. Use the Drive pull-down menu to select the location where the DSU II System Binary File resides.
9. Navigate to and then select the appropriate DSU II System Binary File displayed in the File Selection Dialog box. The system software load automatically begins. A typical load will take approximately nine minutes.

Master Clearing The System

After you load the system operating software, master clear the system. Master clearing returns the entire system configuration to factory settings *and clears all stored auto and speed dial numbers.*

NOTE: *Do not do this unless you want to clear all of the programmed data base.*

1. Type the password **I*746*** (this will get you into the main menu) and **RETURN**.
2. Press **1** for System C.O.S. and **RETURN**.
3. Press **1** for System Defaults and **RETURN**.
4. Press **8** for Master Clear System Data and **RETURN**.
5. Press **y** to confirm and **RETURN**.
6. Press **CTRL C** to return to main menu and **RETURN**.
7. Up-load the class of service data base that you saved before you loaded the system operating software (see the previous paragraph titled *Saving The Class Of Service Data Base* for up-loading procedure).

2.18 Installing The System Options And Accessories

This section contains information on installing the battery back up, the analog terminal interface, and the data interface unit.

2.18.1 Installing The Battery Back Up Assembly

Preparing The Battery Back Up Assembly For Use

The factory ships the battery back up assembly with the harness installed in the enclosure. To complete the assembly, perform the following operations:

- remove the lid from the metal enclosure and save the retaining hardware,
- install the batteries in the metal enclosure and connect the wiring per the schematic shown below,
- replace the lid.

You can wall mount the battery back up enclosure if you wish. If you do, follow the same guidelines and instructions for mounting the common equipment cabinet as set forth at the beginning of this chapter.

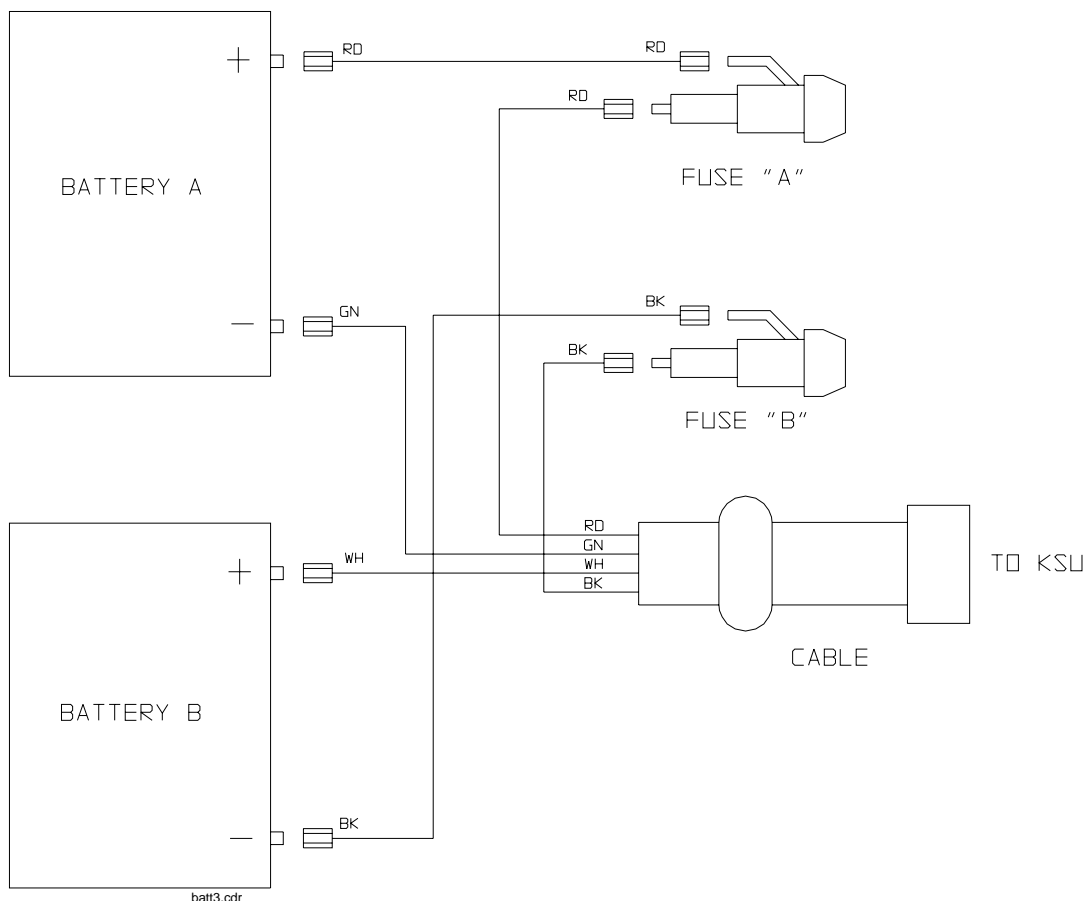

Wiring The Batteries

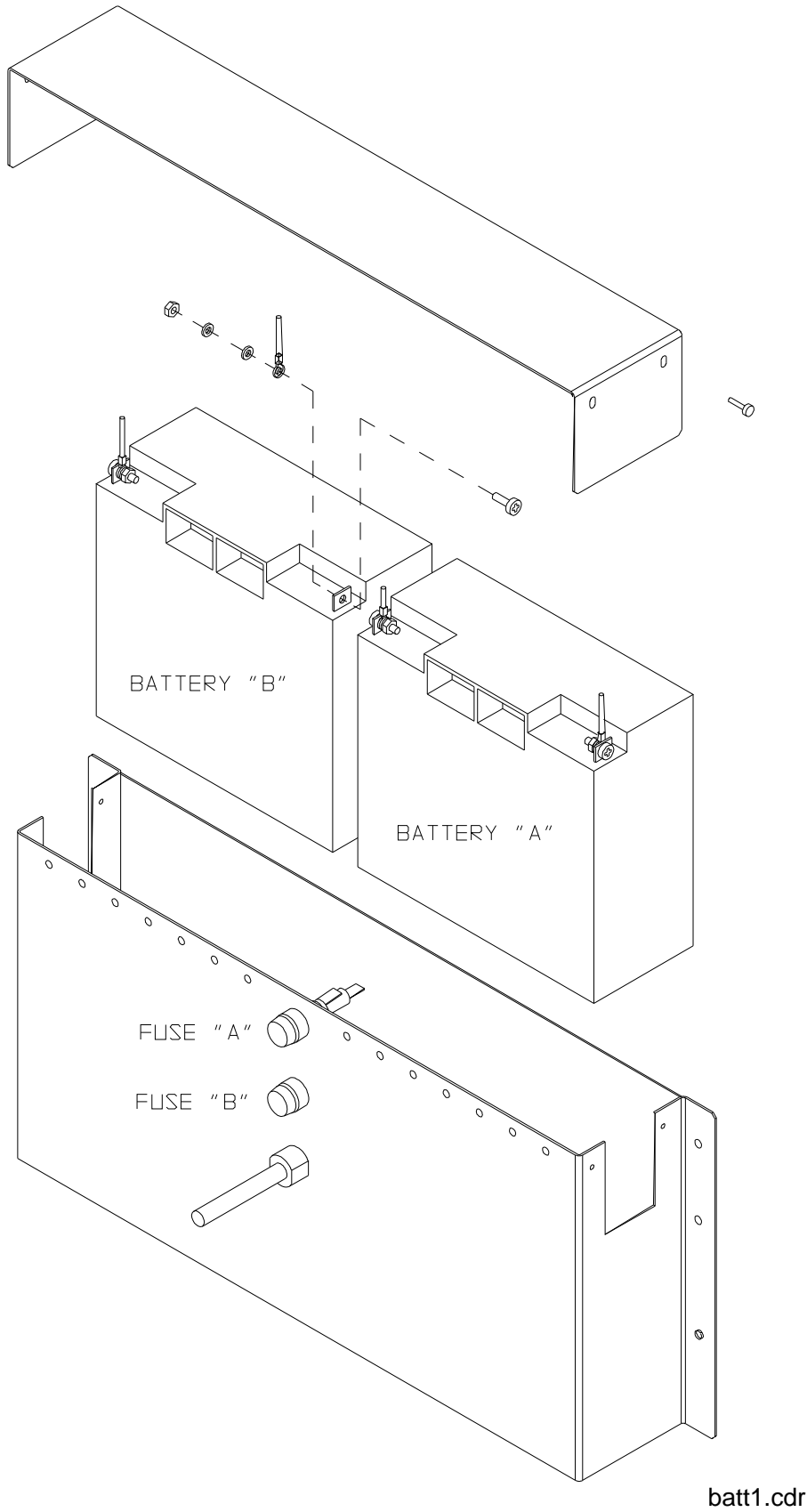

Installing The Batteries

Connecting The Battery Back Up Assembly

The common equipment provides an interface connector for the connection of an optional external battery assembly.

CAUTION

Be sure that the AC power cord is connected to the electrical outlet before connecting an external battery assembly to the common equipment interface connector. This ensures that internal protection circuitry is operating to prevent damage that could result from improper connection.

The external battery assembly provides a minimum of one hour of operation should the AC power to the system be interrupted. The assembly has a 15 ampere-hour current rating and is fused with the following value: 4A 250V 3AG type.

The external battery assembly may include batteries from either of the following suppliers:

- Model PS-12150 from Power-Sonic Corporation, Redwood City CA, 94032
- Model PE12V15 from GS PORTALAC, City Of Industry CA, 91748

The minimum battery backup time for a fully configured system can be calculated using the formula:

$$\text{Back Up Time (in hours)} = \frac{K(15)}{1 + [(0.1) (N)]}$$

K (Constant) = 0.9 for J0408 with or without an expansion module
 0.8 for J0816 with or without expansion modules
 0.8 for J1632 with or without expansion modules

15 = ampere-hours

N = total number of stations

Example:

Assume that a J1632 system plus two JM408 modules are installed along with the optional battery assembly to provide back-up power.

$$\text{Back up time} = \frac{(0.8) (15)}{1 + [(0.1) (48)]} = \frac{12}{5.8} = 2.1 \text{ Hours}$$

During AC operation, the common equipment provides recharging current to maintain the voltage potential of the external battery assembly at an operational level. The charging circuit may not provide an adequate charge if an installed battery assembly has a current rating of greater than 40 ampere-hours. You should measure the battery assembly voltage every three months.

For proper backup capabilities, make sure the batteries meet the following specifications:

- With a fully-charged battery assembly disconnected from the common equipment, the measured voltage must be greater than 12 VDC but should not exceed 13.5 VDC.
- With a fully-charged battery assembly connected to the common equipment, the measured voltage should be less than 13.8 VDC. If the voltage measures higher than this limit, contact your Comdial Technical Services representative.
- The open output of the common equipment battery charger connection measures 13.6-13.8 VDC. If the charging voltage measures higher or lower than this range, contact your Comdial Technical Services representative
- An optional external battery assembly requires approximately 10 hours to completely re-charge to full potential after it has been completely discharged and, in some cases, when initially installed.

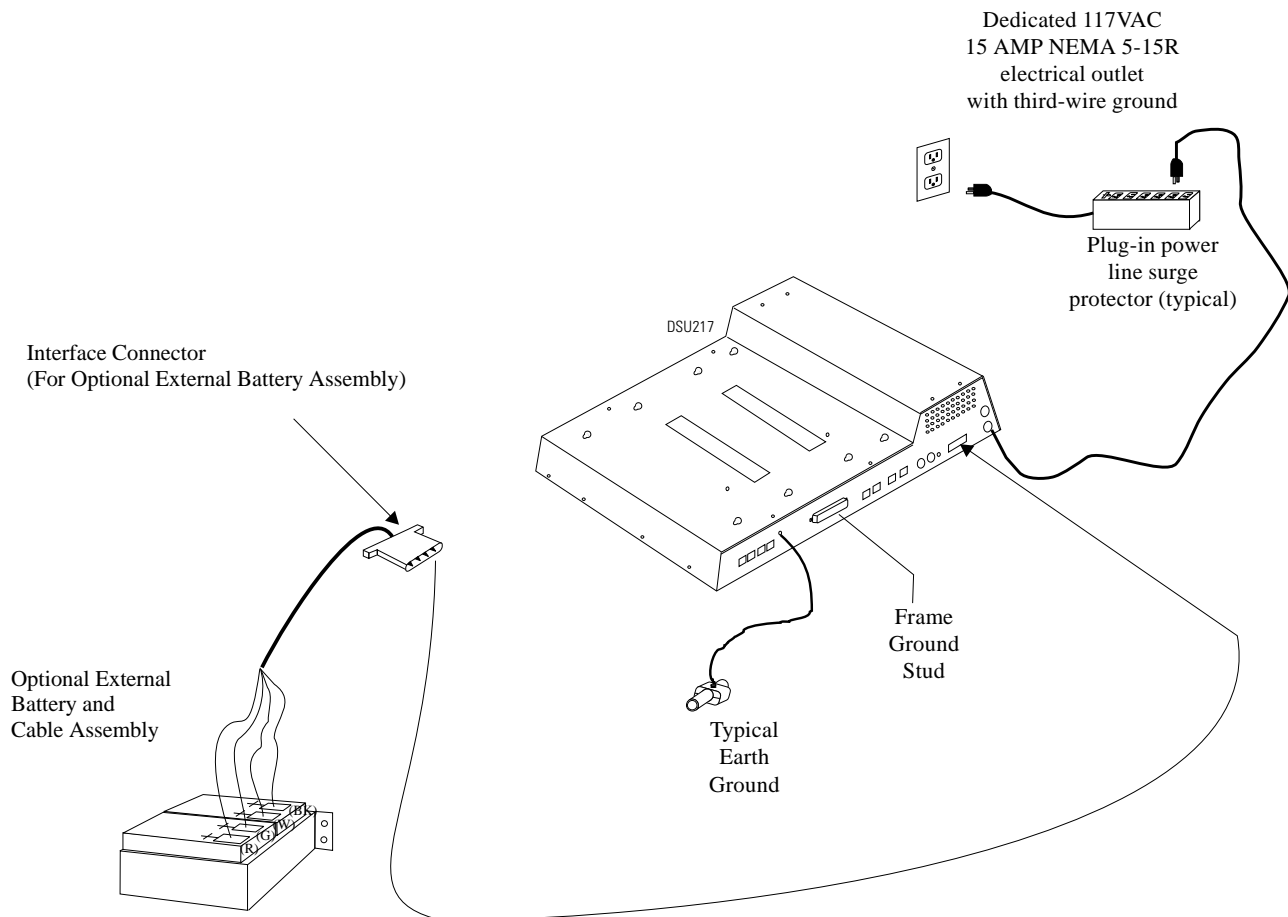

Connecting The Battery Back-Up Assembly

2.18.2 Installing The Analog Terminal Interface

Introducing The Analog Terminal Interface (ATI-D)

The ATI-D is a multipurpose, **on-premise** accessory for the DSU II digital telephone system. It has dual circuits that provide the following features:

- **INDUSTRY-STANDARD TELEPHONE (IST) INTERFACE**-This feature adapts most industry-standard telephone (IST) devices to the digital telephone system. The ATI-D will accept both tone (DTMF) and pulse (rotary) dialing from these devices.
- **SYSTEM INTERCONNECTION**-This feature allows an installer to connect two digital telephone systems to each other using two ATI-Ds and **on-premise** wiring. When interconnected, either telephone system treats the other telephone system as an IST device. The two telephone systems are not integrated together and do not share features.
- **MODEM ADAPTER**-This feature allows the flow of switched data between a data source and a data receiver through the digital telephone system.
- **VOICE MAIL/ANSWERING MACHINE INTERFACE**-This feature allows an installer to connect voice mail systems and automated answering devices to the digital telephone system.

CAUTION

The ATI-D by itself does not support any off-premise service. Never connect the ATI-D to a telephone company-supplied line unless you have first installed an acceptable OPX long loop adapter.

The ATI-D is housed in a self-contained metal enclosure that can be wall mounted if desired. The ATI-D is powered by the digital telephone system through the station port connections and employs an internal ringing generator to generate a ringing signal for an IST. Dual, high-quality, low-loss, balanced, telephone transmission circuitry supports two IST inputs.

One 2-pair cable (four-wire) connects the ATI-D to two common equipment station ports. A single pair of wires connects the external analog IST equipment to the ATI-D. Modular connectors are provided to allow quick connections.

Each ATI-D circuit drives a load with a maximum ringer equivalence number (REN) of 2.0, thus allowing more than one IST connection at each interface input. Check the REN number of the connected IST equipment so as not to exceed the capacity of the ATI-D. Improper operation may result if the REN maximum of the ATI-D is exceeded.

The ATI-D supports a wide variety of IST equipment such as 500 and 2500-type telephones, cordless telephones, voice mail systems, answering machines, FAX machines, and data modems.

Detailing The The Analog Terminal Interface Specifications

Power requirements:	Supplied by the common equipment
Ringing voltage:	55 VAC Nominal @ 20 Hz (45 VAC minimum) Power rated to maximum REN = 2.0
Battery feed voltage:	24 VDC nominal
Loop current limits between ATI-D and IST interface:	20 ma min. at 620 ohms 70 ma max. at 0 ohms
DC loop limits from ATI-D to industry standard interface per port:	620 ohms maximum including interfaced telephony device. (Approximately 4000 feet with #26 AWG twisted-pair cable and 300 ohm device load.) (Approximately 500 feet if two IST devices are connected in parallel on same tip and ring pair.)
DC loop limits from ATI-D to voice mail system:	Approximately 1000 feet with #26 AWG twisted-pair cable.
Cable insulation resistance:	30,000 ohms minimum
Cable requirement ATI-D to system	2-pair twisted cable; 25 feet maximum length. (Both common equipment station ports must always be connected to the ATI-D for every installation, and they must be paired in sequence - 12 & 13, 14 & 15, etc.)
Cable terminations:	623-type, 4-conductor mini jacks
Dialing:	Industry-standard DTMF or Dial pulse (rotary) with nominal make/break ratio of 40/60 @ 10 PPS
Ringing cadence:	Outside calls = 2 second on - 4 seconds off Intercom calls = Two bursts: 1 second on - .5 second off, 1 second on - 3.5 seconds off
Operating temperature:	32-122 F (0-50 C)
Humidity:	90 % relative, non-condensing
Height:	2.375 inches
Width:	8.062 inches
Length:	11.125 inches
Weight:	4 lbs. (plus 2 lbs. for packing material)
FCC registered and listed for safety compliance as part of digital telephone system	
FCC certified, Part 15 (class A)	

Mounting The Analog Terminal Interface

Refer to Section 2.1 at the beginning of this chapter for system mounting considerations that are also applicable to the analog terminal interface.

Mounting Procedure

1. Unpack and carefully inspect the ATI-D for shipping damage. Notify the shipper immediately of any damage found. Verify that the package contains all parts and accessories needed for proper installation and operation.
2. If a backboard is required at the mounting location, attach it securely to provide a stable mounting surface.
3. Use the base of the ATI-D as a template or measure for mounting hole locations per the dimension details shown in the illustration on the next page.
4. Drill holes of a proper size to accommodate the hardware being used into the mounting surface. If necessary, prepare these holes with inserts, anchors or other attachment devices as dictated by the type of mounting surface.
5. Insert the two top screws into the mounting surface and tighten them to within approximately 1/8-inch of the surface.
6. Hang the ATI-D on the top screws using the mounting holes located on the rear of the cabinet. Note that these holes are elongated with an enlargement at one end. This feature allows the cabinet to snap down on the screws to secure the mounting when the cabinet is hung on them.
7. Insert a third screw through the mounting tab located on the lower edge of the cabinet and into the mounting surface; tighten it into place.

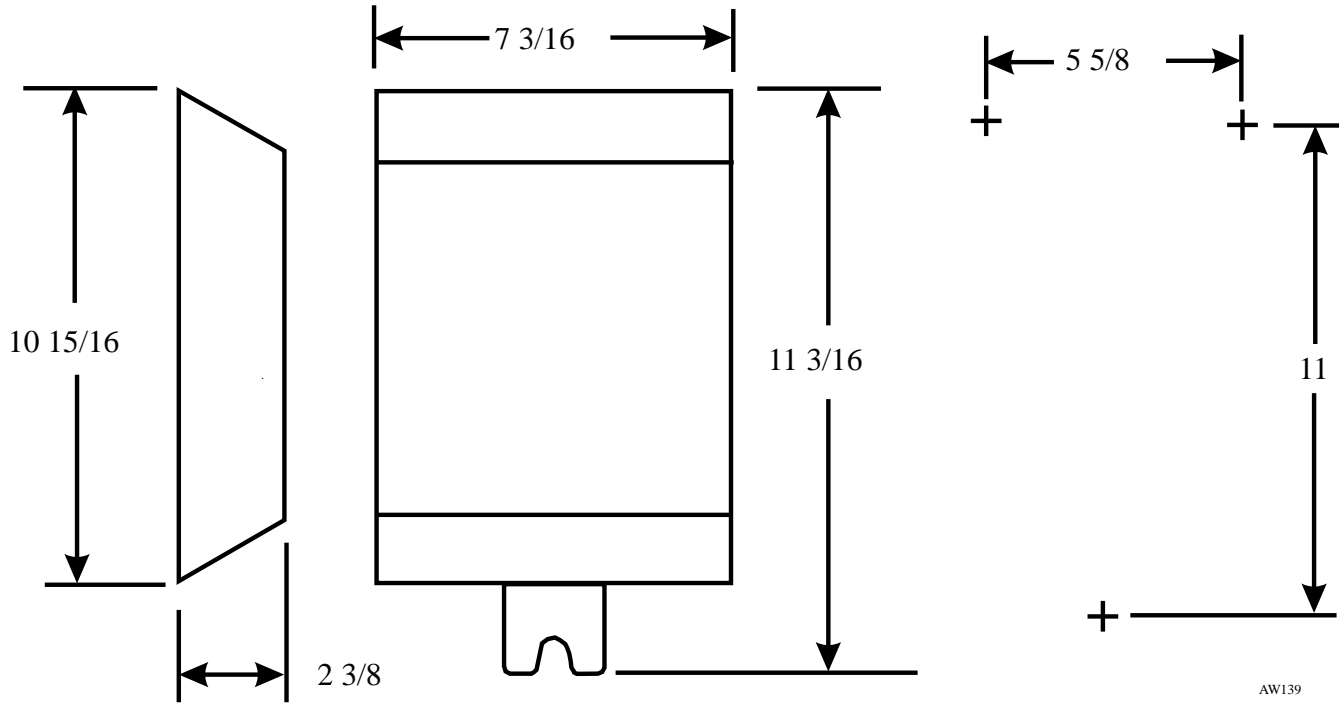

Outline Dimensions
(In Inches)

Spacing For
Mounting Hardware
(In Inches)

Detailing The ATI Dimensions

Connecting The Analog Terminal Interface

Connect the ATI-D per the diagram detailed on the following page. A grounding wire is not required for operation; however, one is desirable for decreasing radio frequency interference and electrostatic discharge susceptibility. The ATI-D housing provides a frame ground stud for this purpose. Connect a #10 or #12, insulated, solid copper wire between this ground stud and a reliable earth ground.

NOTE: *You must connect both station ports to the ATI-D, even if you plan to use only one IST device. Connect the first ATI-D port to an even station port. All ATI-D ports must be paired.*

CAUTION

Be careful when connecting the wiring between the common equipment and the ATI-D. Be sure to connect the common equipment station ports to the COMMON EQUIPMENT (KSU) jack on the ATI-D. Damage to the ATI-D could occur if this wiring is mistakenly connected to the IST jack.

Use a voltmeter to check for the presence of voltage on the ATI-D IST jack.

1. Be sure that you have installed all the wiring between the ATI-D and the common equipment station ports.
2. Measure for DC voltage on IST jack:
 - Measure between TIP leads and common equipment grounding stud.
 - Measure between RING leads and common equipment grounding stud.
 - Measure between TIP leads and RING leads.

The measured voltage must be within following limits:

MEASUREMENT	VOLTAGE
Tip to Ground	+3 to +11 VDC
Ring to Ground	-13 to -21 VDC
Tip to Ring	+23 to +25 VDC

(The TIP lead is positive with respect to the RING lead.)

Understanding Analog Terminal Interface Programming Requirements

Once you have connected the ATI-D to the system there are several programming steps that you should take to make it fully operational. Refer to Chapter 3, Section 3.10 for complete details.

Installing A Voice Mail Interface

You can use the ATI-D to provide interfacing for a customer-supplied voice processing system. The ATI-D, using paired station ports (such as 12 and 13 or 14 and 15), will support two voice mail ports.

To complete the installation, connect the voice mail ports to the IST jacks on the ATI-D.

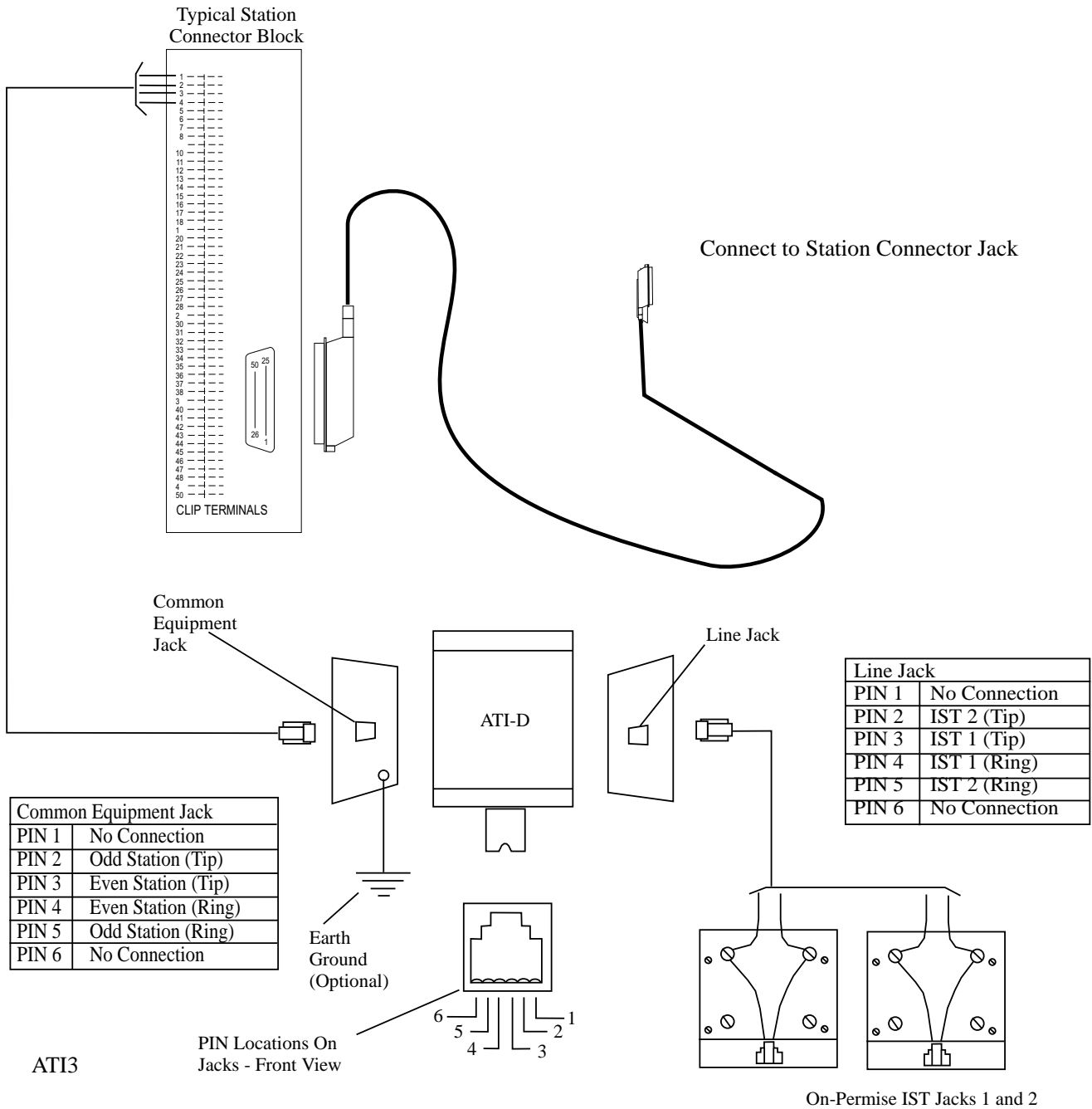

Interconnecting The ATI-D

Installing An OPX Long Loop Adapter To The Analog Terminal Interface For Off-Premise Service

As stated previously, the analog terminal interface is an on-premise device. You must use an OPX long loop adapter if you wish to adapt the ATI-D to support an off-premise application. An OPX long loop adapter connects to a single telephone line and can greatly extend the line's loop length (the Proctor Model 46222 adapter*, for example, can extend line length to 30,000 feet).

*Proctor & Associates Company, Redmond WA

CAUTION

When you connect an adapter to an off-premise extension (OPX), you must install primary protectors in series with the tip/ring pair of the telephone line that is routed to the OPX. This action is necessary to protect both the user and the equipment from transient voltage spikes that can travel through the cable. The telephone company offers basic protection against this condition; however, that protection is usually designed to safeguard the central office circuits and you cannot rely upon it to protect common equipment. To help insure that external over-voltage surges do not damage the system, installation specialists recommend that you install and properly ground gas discharge tubes or similar primary protection devices on the telephone line that routes between the adapter and the OPX.

To install the OPX long loop adapter:

- Follow manufacturer's instructions for unpacking, inspecting, mounting and wiring the adapter unit.
- Plug a modular cable into the system jack on the adapter and connect the opposite end of the cable to the IST jack on the ATI-D.
- Plug a modular cord into the telephone jack on the adapter and connect the opposite end of the cord to the OPX line.
- Plug the adapter power cord into a standard 117 VAC, 3-wire electrical outlet.

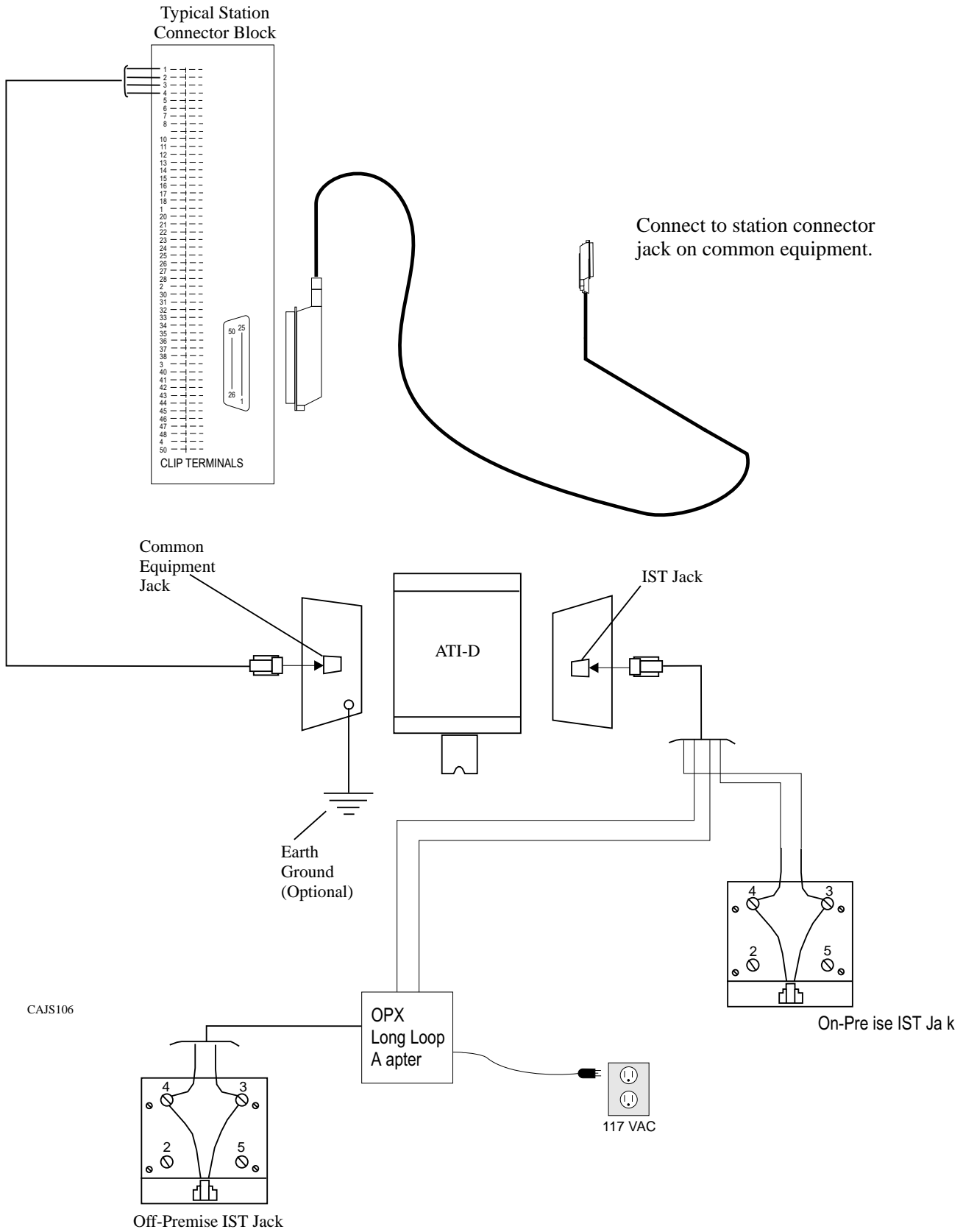

Installing The Long Loop Adapter

2.18.3 Installing The Data Interface Unit

Unpack the Data Interface Unit (DIU) and check for the following parts:

- Telephone line cord
- Power cable with attached transformer.

Installing The Mechanical Components

You can install the DIU in either a free-standing manner or you can mount it on a wall.

When mounting the DIU on a wall:

1. Select a location that is close to a standard 115 VAC electrical wall outlet. The location you select should also be convenient to the digital telephone and the Industry Standard Telephone (IST), FAX, or modem-whichever one you will be connecting to the DIU.
2. Once you have selected the location for mounting the DIU, mark two locations for the mounting screws as follows:
 - a. make the first mark,
 - b. measure 3 13/16 inches horizontally from the first mark and make the second mark.

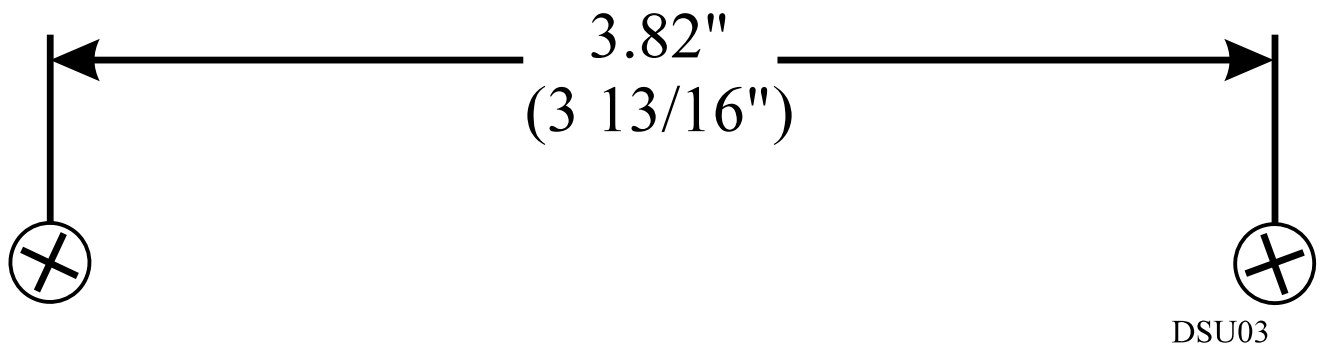

Mounting The Data Interface Unit

3. Install two #8 X 3/4-inch screws in the wall at the locations you marked in step 2. Tighten the screws until the screw heads are 1/4-inch from the surface of the wall.
4. Place the DIU on the wall with the screw heads inserted into the slots provided on the bottom surface of the DIU. Slide the DIU onto the screw heads until it is firmly attached to the screws.

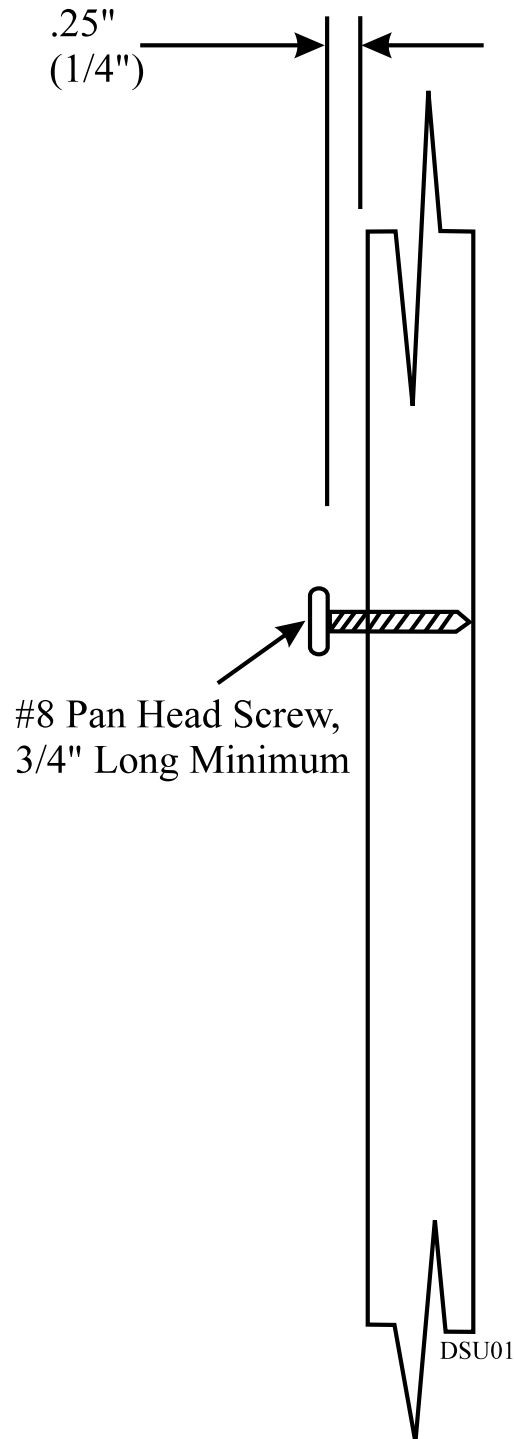

Installing The DIU Mounting Screws

Making The Data Interface Unit Cable Connections

Four cable connections are required to the DIU-station line cord, digital telephone line cord, IST/FAX/MODEM line cord, and power cable.

1. Disconnect the line cord on the digital telephone from the digital station port connector and plug it into the connector labeled PHONE on the DIU.
2. Plug the line cord from the IST device you are installing with the DIU (such as a FAX machine, or modem) into the DIU connector labeled FAX/MODEM.
3. Plug the transformer attached to one end of the power cable into a 115 VAC electrical wall outlet. Connect the other end of the power cable into the DIU connector labeled POWER. The green LED on the DIU will be on to indicate power is being supplied to the DIU.
4. Plug one end of a standard line cord into the connector labeled LINE on the DIU. Plug the other end of the line cord into the digital station port connector.

NOTE: DIU power loss will create the same symptoms as the disconnection of the DIU from the digital telephone system. If this occurs, plug the multiline digital telephone directly into a digital station port connector.

Preparing The DSU II For DIU Operation

Once you have verified that the system contains the correct software, you must program the system for DIU operation. See Chapter 4, *System Programming* for programming details.

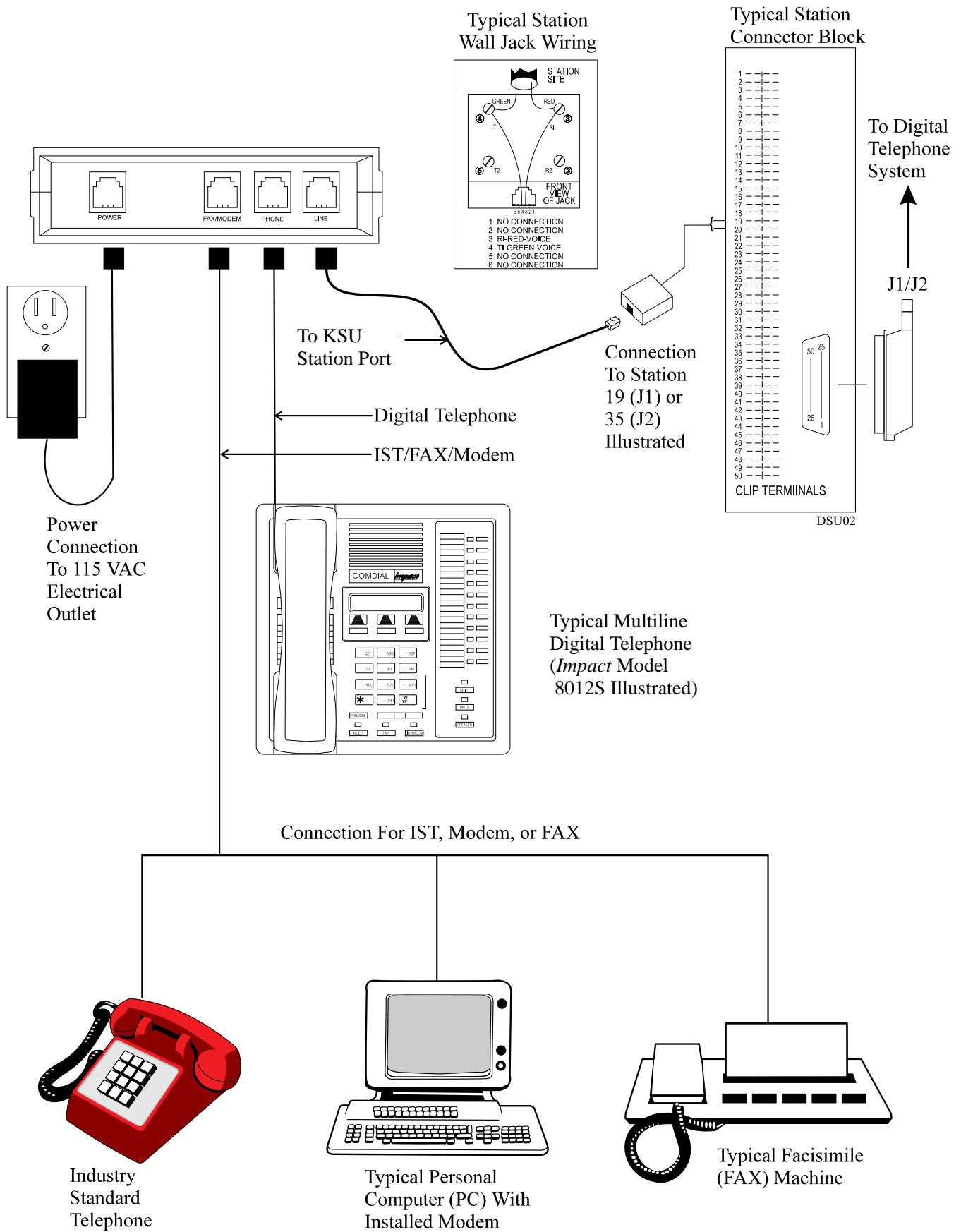

Making The DIU Cable Connections

2.18.4 Supporting Caller Identification Service

You can provide Caller ID information through the serial data port COM2 using the Caller ID Interface (product code CID08) and a special equipment-supplied cable. Caller ID information for incoming calls shows on the displays of the system's LCD speakerphones.

Make the connections that are detailed in the following statements.

- Connect the CO lines providing Caller ID data to both the common equipment and the CID08 line jacks in the same numerical order.
- Connect the CID08-supplied cable between the CID08 and the COM2 serial data connection on the common equipment.
- With the Caller ID Interface installed, you can also add two leads to provide the TD and SG signals to a data printer or personal computer (PC). These leads are useful for adding caller ID enhancement to the SMDA/SMDR printout or for providing messages in the ASCII format suitable for use with PC-based applications programs.

dsu261.cdr

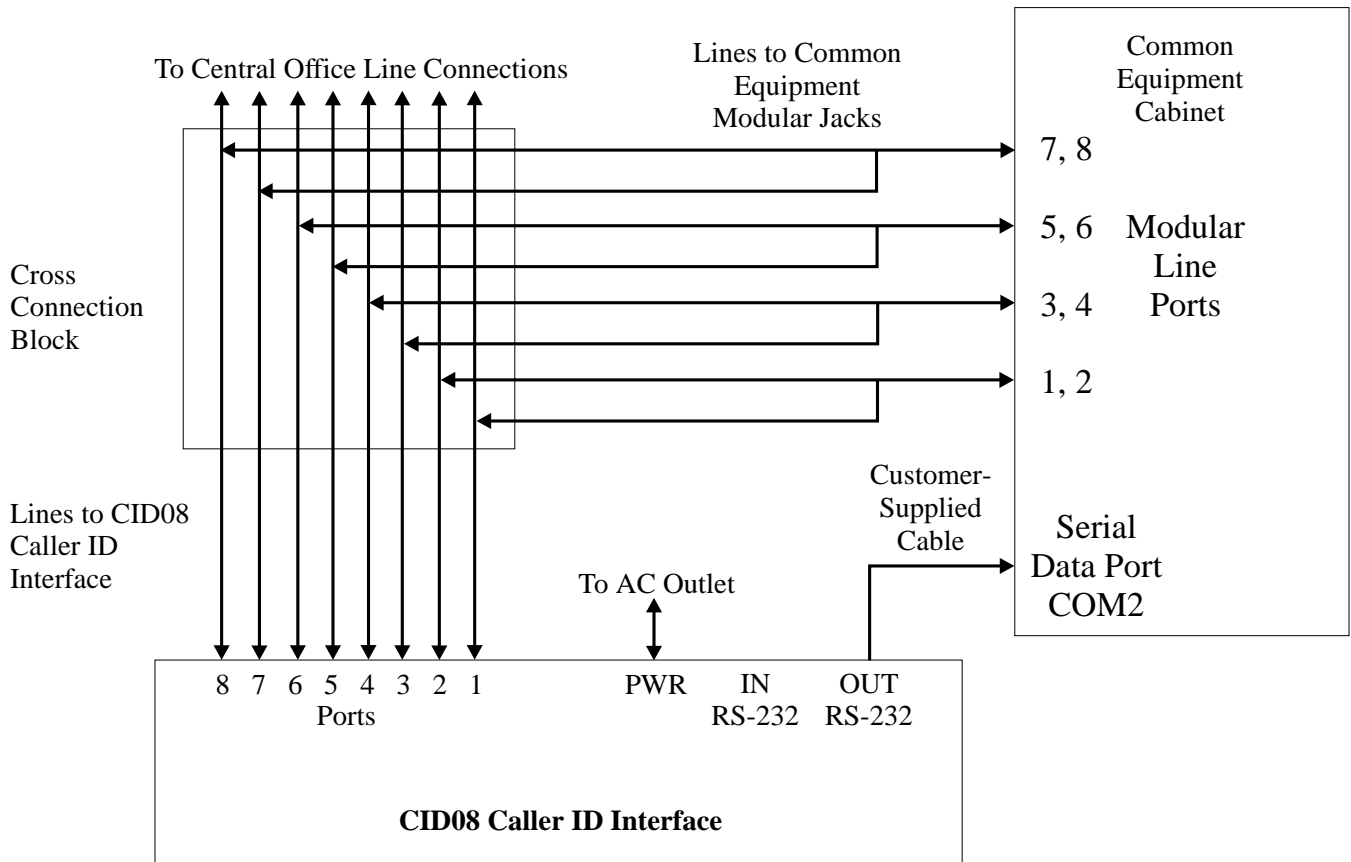

Connecting The Caller ID Interface

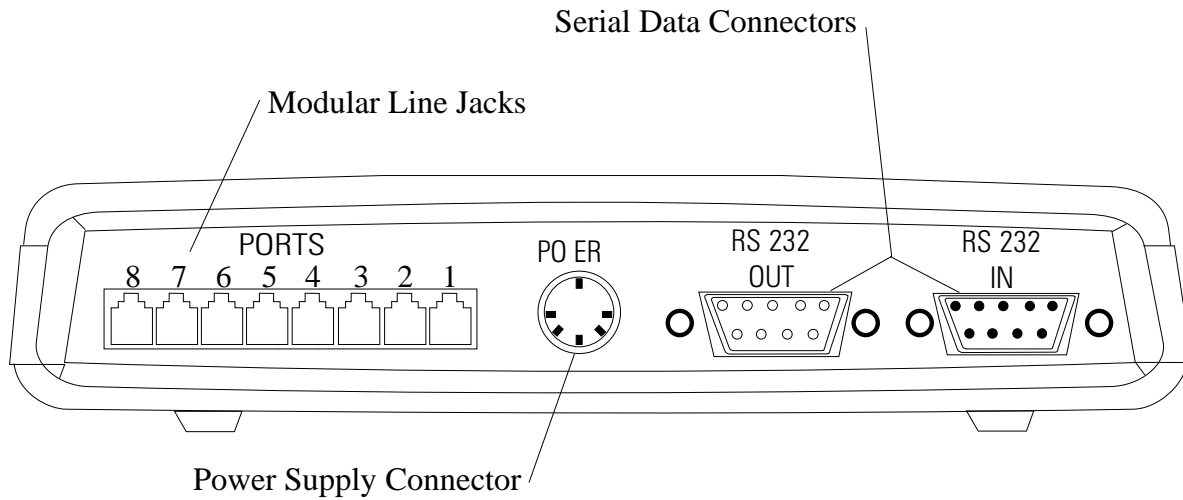

Locating The CID08 Connectors

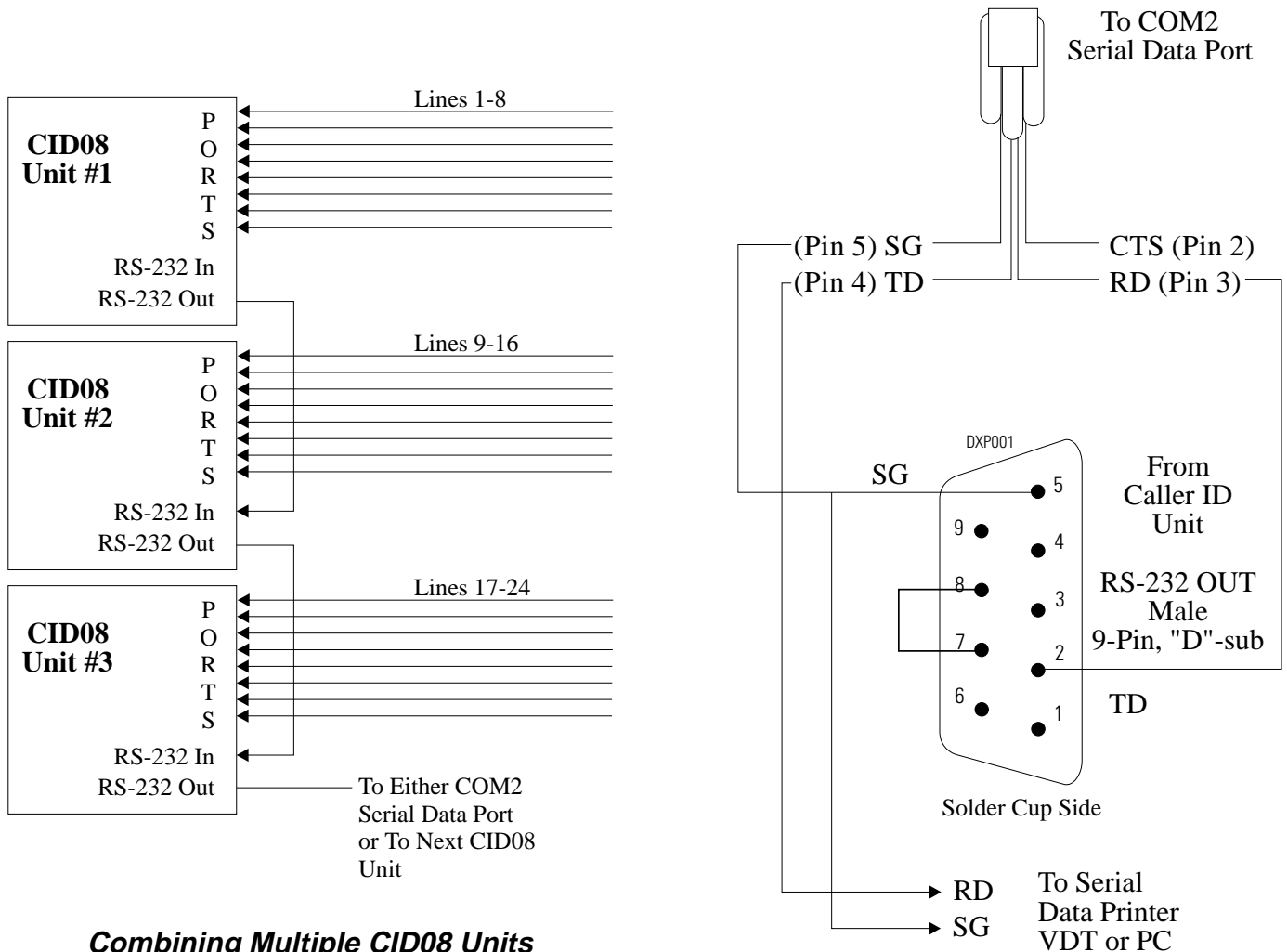

Combining Multiple CID08 Units

Detailing The CID08 Cable Connections

dsu264.cdr

Setting The Caller ID Parameter Switches

The Caller ID device has two banks of parameter switches located on its front panel.

Set the switches of the S1 switch bank per the following rule:

- If you are combining units (more than 8 lines are used), turn all switches in Dip Switch S1 **OFF** except for switch 7. Turn S1 switch 7 **ON** when combining units. If you are not combining units, turn all S1 switches **OFF**.

You must set the switches of the S2 switch bank in a certain manner to enable Caller ID operation. Switches S2-1 through S2-5 set the baud rate, data bits, and parity, while switches S2-6, S2-7, and S2-8 set the unit address for each device. Set the switches of the S2 per the details shown in the following tables.

SWITCH S2-1	SWITCH S2-2	BAUD RATE
OFF	OFF	1200
ON	OFF	2400
OFF	ON	4800
ON	ON	9600*

* Set ON, ON (9600 baud) for DSU operation.

SWITCH S2-3	DATA BITS
OFF	7
ON	8*

*Set ON (8 data bits) for DSU operation.

SWITCH S2-4	SWITCH S2-5	PARITY
OFF	OFF	NO PARITY*
ON	OFF	ODD
OFF	ON	EVEN
ON	ON	EVEN

* Set OFF, OFF (no parity) for DSU operation.

SWITCH S2-6	SWITCH S2-7	SWITCH S2-8	DEVICE
OFF	OFF	OFF	1
ON	OFF	OFF	2
OFF	ON	OFF	3

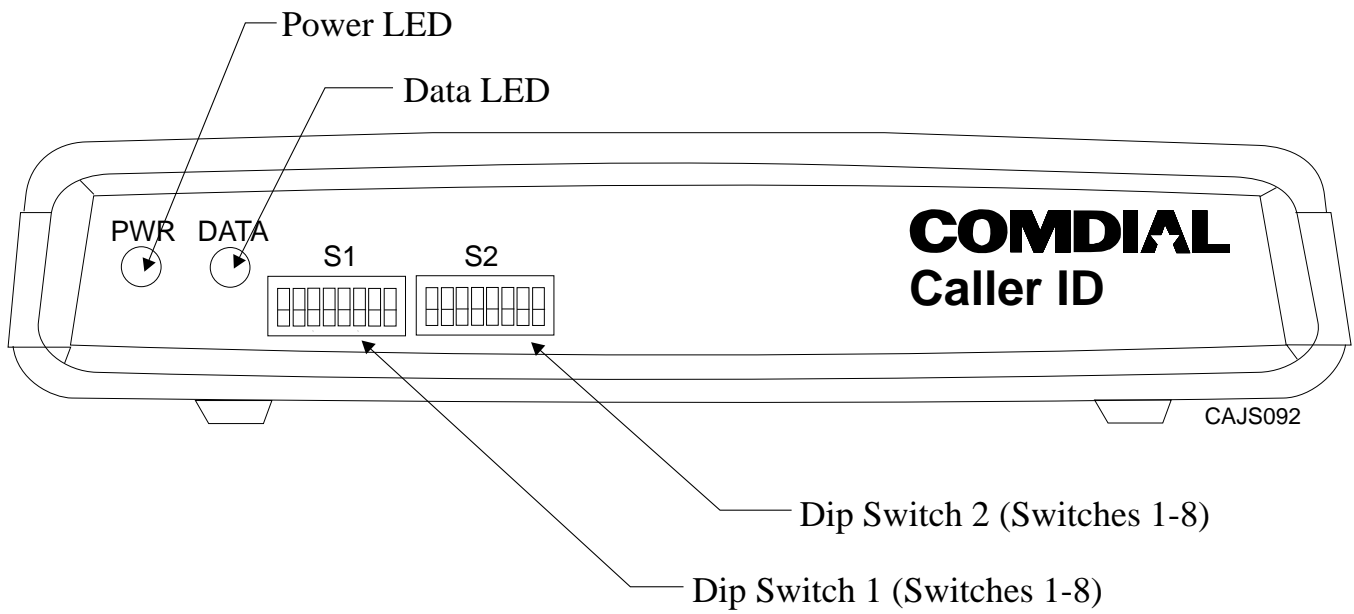

Locating The CID08 DIP Switches

2.18.5 Supporting The Tracker Paging System

The optional Tracker paging system allows you to send alpha/numeric or numeric-only messages to the Tracker Pagers assigned to a station extension number. The type of message that the system delivers is dependent on the Tracker Pager model being used. Tracker's paging option requires only one connection to the digital telephone system; however, you will need to take several programming steps to make it operational.

- If you use station 10 programming to configure the system, install the Tracker base station to the common equipment cabinet's COM1 serial data port. Then, after you have completed the installation, take the programming action detailed in Chapter 3, Section 3.17.
 - If you use a video display terminal (VDT) to configure the system, you must connect it to the COM1 serial data port and ***you must take programming action to enable the Tracker Pager option and enable Tracker Pagers at stations before you actually install the Tracker Pager system.*** (This is necessary since the Tracker Pager system also uses the COM1 serial data port and there would be no way to program with a VDT if the Tracker Pager system was already installed.)
1. When you finish programming, press CONTROL C for the main menu, and log out from the programming mode.
 2. Disconnect the VDT from COM 1. As soon as you do this, the system begins polling COM1 every two seconds and waiting for a response from a Tracker base station.
 3. Connect the Tracker Pager system to COM1. As soon as you connect the Tracker base station to COM1, the DSU II system recognizes the Tracker base station's presence and makes Tracker Pager features available to the system users.

NOTE: While the Tracker base station remains connected, the system continues to poll the port every 10 seconds to verify its presence. This means that if you disconnect the Tracker base station to reconnect the VDT, you may have to wait as long as 10 seconds for the system to notice that you have replaced the Tracker base station with a VDT.

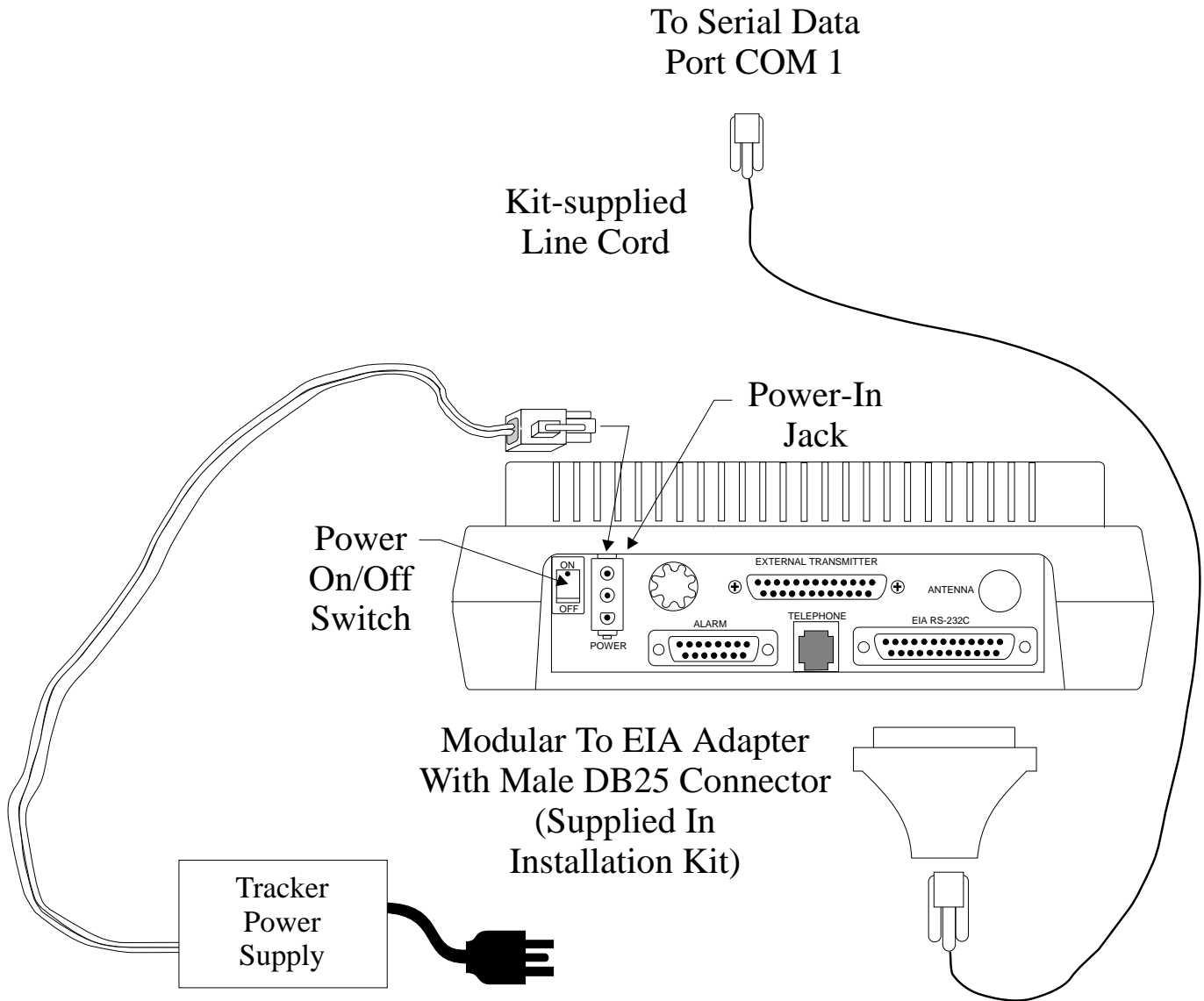

dsu262.cdr

Connecting The Tracker Base Station

2.18.6 Supporting DVA Operation

Digital voice announcing uses a hardware peripheral device (product code DVA01) connected to a digital station port to play pre-recorded announcements and messages during an in-progress call. The DVA stores the pre-recorded messages in its memory for recall when needed.

The DVA derives its operating power from the common equipment cabinet's digital station port; however, the DVA also provides internal connections for a battery. When installed, this battery powers memory that holds the stored messages should someone disconnect the DVA for some reason. Should you need to replace this battery, use one that meets the following specifications:

- Output-8.4 volts, 100 mAh
- Type-Sealed, rechargeable Ni-Cad battery
- Model-Varta V7/8R or equivalent (Varta Batteries Inc., 300 Executive Blvd., Elmsford NY 10523)

To install the DVA device,

1. Position the DVA01 in a convenient location.
2. Connect the DVA01 to a digital station port using an RJ14C-configured standard two-wire line cord.
3. If you need to input pre-recorded messages during programming, use a customer-supplied audio cable terminated with 3.5mm (1/8 inch) phone plug on one end and appropriate tape recorder mating connector on the other end.
4. Refer to Chapter 4 for details, and program the system for DVA operation.

DVA003

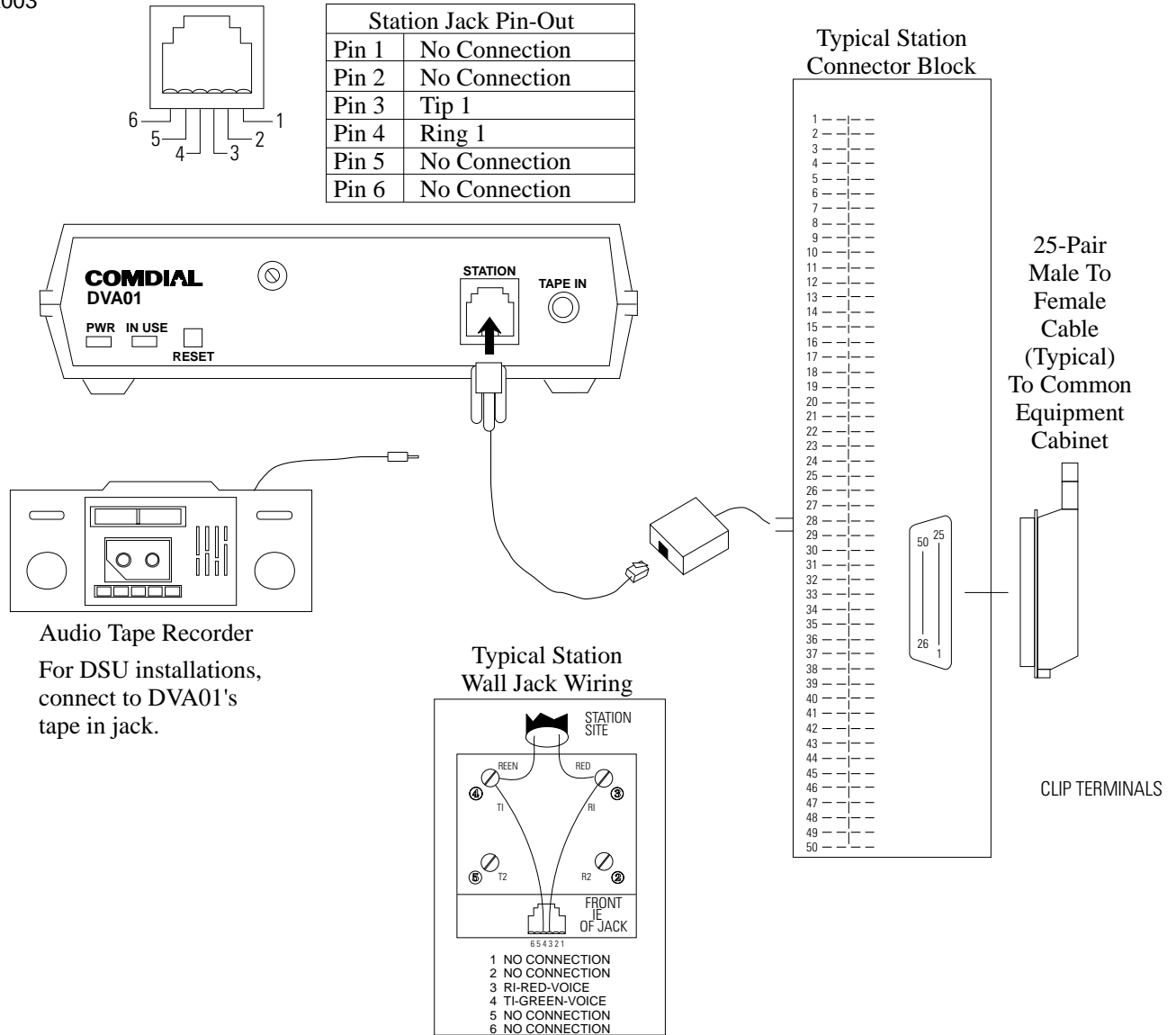

Interconnecting The DVA Device

2.18.7 Installing The Personal Computer Interface Unit

(Projected Availability of this feature is first quarter of 1997)

The Personal Computer Interface Unit (PCIU) is a device that you can connect between a digital station port and its proprietary telephone. The PCIU allows telephone users to initiate telephone and voice mail related functions from their personal computer (PC).

The PCIU includes Service Provider Interface (SPI) software on computer diskettes. When you install this SPI software on a PC, the PC users can employ their Telephony Applications Programming Interface (TAPI), third-party Microsoft* Windows applications programs to control many useful telephone functions.

When you make the Visual Voice Processing (V.V.P.) Visual Call Manager (VCM) software option available, the voice mail system can use the serial data path to the PCIU to send messages to the telephone's display and to the SPI on the PC.

*Microsoft is a registered trademark of Microsoft Corporation, Redmond, Washington

Making The PCIU Cable Connections

Four cable connections are required to the PCIU-station line cord, digital telephone line cord, PC cable, and power cable.

1. Disconnect the line cord on the digital telephone from the digital station port connector and plug it into the connector labeled PHONE on the PCIU.
2. Connect the supplied serial data cable between the PC's serial data port (COM port) and the PCIU's serial port connector.
3. Plug one end of a standard line cord into the connector labeled LINE on the PCIU. Plug the other end of the line cord into the digital station port connector.
4. Plug the transformer attached to one end of the power cable into a 115 VAC electrical wall outlet. Connect the other end of the power cable into the PCIU connector labeled POWER. The green LED on the PCIU will be on to indicate power is being supplied to the PCIU.

NOTE: PCIU power loss will create the same symptoms as the disconnection of the PCIU from the digital telephone system. If this occurs, plug the digital telephone directly into a digital station port connector.

Making The PCIU Operational

To make the PCIU operational, you need only follow the instructions enclosed with the SPI software, and load it on the user's PC. There is no programming action required on the DSU II digital telephone system to make the PCIU operational; however, it does require that the software revision be at 2A or later. However, if you use the PCIU with the V.V.P. voice mail system, you must program enable the Visual Voice Mail (VVM) option.

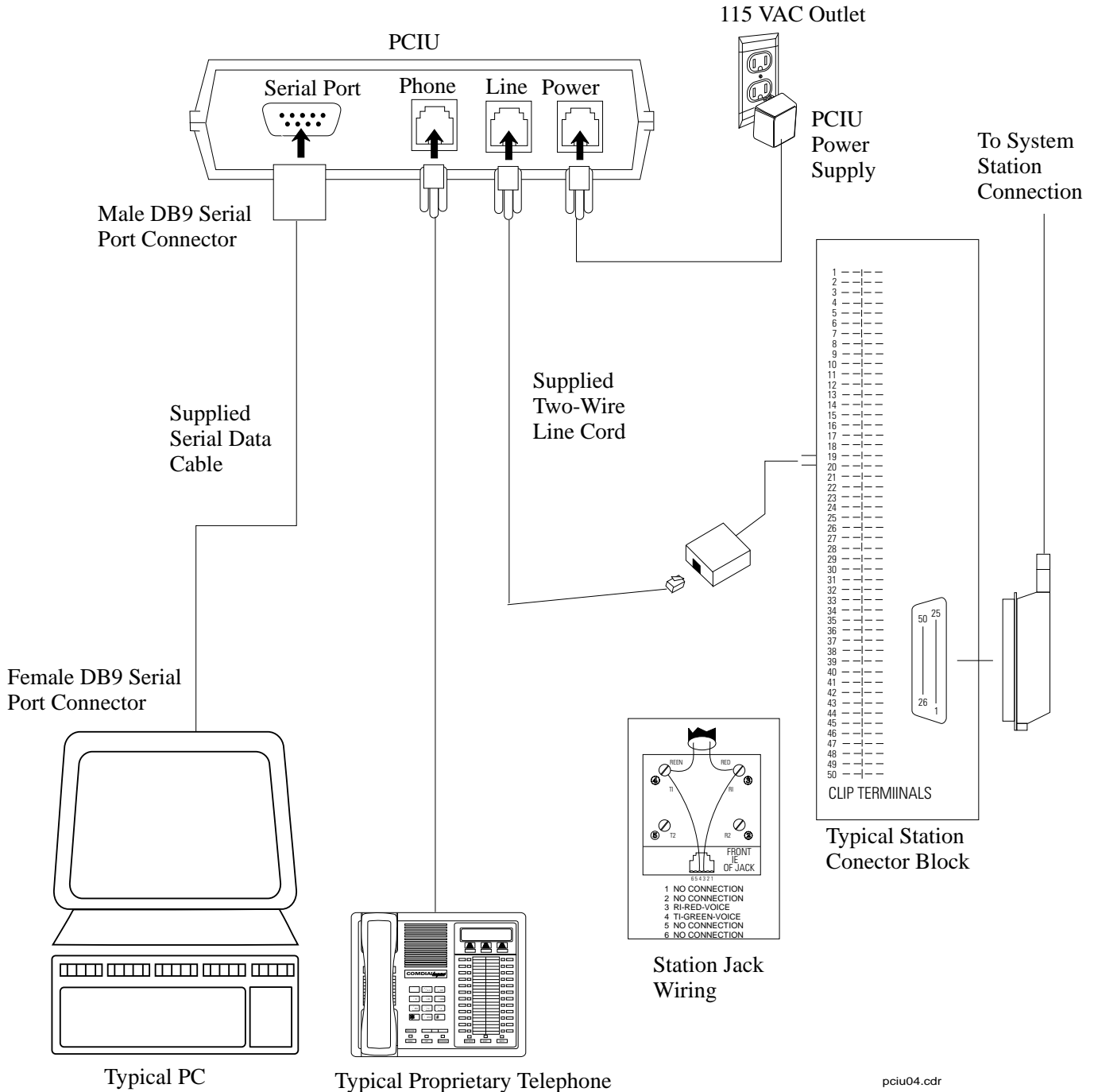

Making The PCIU Cable Connections

2.18.8 Connecting The Versatile Voice Processing Voice Mail System

The Versatile Voice Processing (VVP) voice mail system provides voice mail and automatic attendant features to the DSU II digital telephone system. A Comdial proprietary voice board and proprietary software package installed in a personal computer (PC) provides the VVP feature. A separate publication, which is supplied with the VVP equipment, discusses its installation, programming, and operating details. The information contained below discusses the VVP connections to the DSU II.

The VVP requires industry-standard telephone (IST) station ports for its interface to the DSU II. Each VVP voice port requires its own IST interface. To provide the necessary IST interfaces, you must either install a JM008 expansion module (Section 2.14.2) or connect an ATI-D (Section 2.18.2) to the DSU II common equipment cabinet. Remember, one JM008 expansion module provides eight IST ports while each ATI-D provides two.

The VVP software uses both voice and signalling paths between the DSU II and the VVP voice processing circuit board. By using an in-band signalling technique, the IST ports handle both of these paths. The efficiency of in-band signalling is dependent upon the availability of idle paths, and busy systems that rely on in-band signalling sometimes slow down. Busy systems work more efficiently when the signalling path is provided through a serial data connection between the VVP's PC and the DSU II's common equipment. This arrangement is termed serial integration. You must provide serial integration if VVP includes the optional Visual Voice Mail (VVM) feature or if you are using the PCIU (Section 2.18.7) to provide this feature to a single system telephone.

Connect Voice Board Port To DSU II's Industry-Standard Telephone Port (Supplied By Either JM008 Expansion Module Or ATI-D Analog Terminal Interface Device)

Industry-Standard Four-Conductor Line Cord

DSU II Cabinet COM1 and COM2 Serial Data Ports

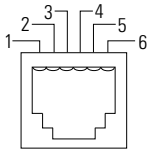

- Pin 1 = No Connection
- Pin 2 = (CTS) Clear to Send
- Pin 3 = (RD) Receive Data
- Pin 4 = (TD) Transmit Data
- Pin 5 = (SG) Signal Ground
- Pin 6 = No Connection

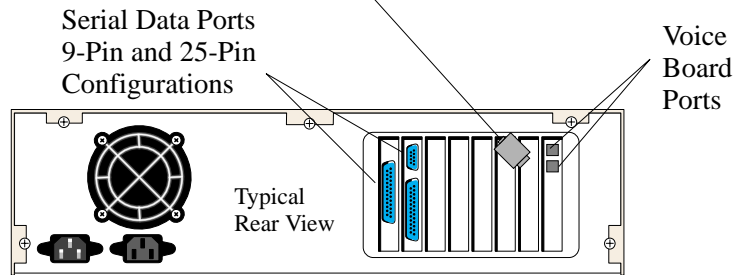

Versatile Voice Processing Voice Mail Computer

For Serial Integration Connect DSU II's COM1 or COM2 Serial Data Port To PC's Serial Data Port

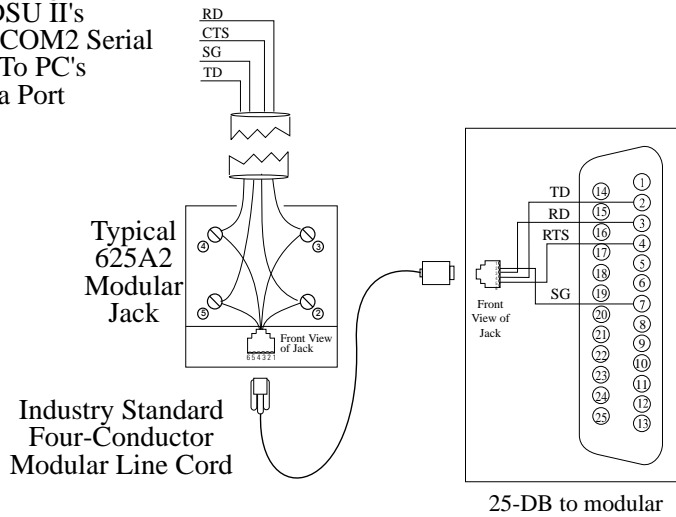

Typical modular to EIA adapter wiring shown for reference only. (Viewed from rear of PC)

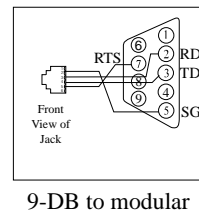

Connect to matching serial data port on voice mail computer as appropriate

email004.cdr

Connecting VVP To The Digital Telephone System

2.19 FCC Rules And Regulations

This electronic key system complies with Federal Communications Commission (FCC) Rules, Part 68. The FCC registration label on the common equipment cabinet contains the FCC registration number, the ringer equivalence number, the model number, and the serial number or production date of the system.

Notifying The Telephone Company

Unless a telephone operating company provides and installs the system, the telephone operating company which provides the lines must be notified before a connection is made to them. Provide the telephone company with the lines (telephone numbers) involved, the FCC registration number, the ringer equivalence number, the Facilities Interface Code (FIC), the Universal Service Ordering Code (USOC), and the USOC jack required. The FCC registration number and the ringer equivalence number is provided on the label attached to the common equipment. The FIC and USOC information is provided in the equipment's general specifications found in equipment system manual. The user/installer is required to notify the telephone company when final disconnection of this equipment from the telephone company line occurs.

Understanding Telephone Network Compatibility

When necessary, the telephone operating company provides information on the maximum number of telephones or ringers that can be connected to one line, as well as any other applicable technical information. The telephone operating company can temporarily discontinue service and make changes which could affect the operation of this equipment. They must, however, provide adequate notice, in writing, of any future equipment changes that would make the system incompatible.

Understanding Installation Requirements

Connection of the electronic key system to the telephone lines must be through a universal service order code (USOC) outlet jack supplied by the telephone operating company. If the installation site does not have the proper outlet, ask the telephone company business office to install one. The correct outlet jack for this system is either a type RJ21X or type RJ14C.

Understanding Party Line And Coin Line Limitations

Local telephone company regulations may not permit connections to party lines and coin lines by anyone except the telephone operating company.

Troubleshooting The Service Problem

If a service problem occurs, first try to determine if the trouble is in the on-site system or in the telephone company equipment. Disconnect all equipment not owned by the telephone company. If this corrects the problem, the faulty equipment must not be reconnected to the telephone line until the problem has been corrected. Any trouble that causes improper operation of the telephone network may require the telephone company to discontinue service to the trouble site after they notify the user of the reason.

Authorizing Repairs

FCC regulations do not permit repair of customer owned equipment by anyone except the manufacturer, their authorized agent, or others who might be authorized by the FCC. However, routine repairs can be made according to the maintenance instructions in this publication, provided that all FCC restrictions are obeyed.

Recognizing Radio Frequency Interference

The electronic key system contains incidental radio frequency generating circuitry and, if not installed and used properly, may cause interference to radio and television reception. This equipment has been tested and found to comply with the limits for a Class A computing device pursuant to Subpart J of Part 15 of FCC Rules. These limits are designed to provide reasonable protection against such interference when operated in a commercial environment. Operation of this equipment in a residential area may cause interference to radio and television reception; in which case the user is encouraged to take whatever measures may be required to correct the interference. If this equipment does cause interference to radio or television reception, which can be determined by turning the equipment off and on, the user is encouraged to try to correct the interference by one or more of the following measures: Reorient the television or radio's receiving antenna, and/or relocate the DSU, the individual telephone stations, and the radio or TV with respect to each other. If necessary, the user should consult the manufacturer or an experienced radio/television technician for additional suggestions. The user may find the following booklet prepared by the Federal Communications Commission helpful: "How to Identify and Resolve Radio-TV Interference Problems." This booklet is available from the Government Printing Office, Washington D.C. 20402. Stock No. 004-000-00345-4.

This equipment has been tested and found to comply with the limits of a Class A digital device, pursuant to Part 15 of the FCC Rules. These limits are designed to provide reasonable protection against harmful interference when the equipment is operated in a commercial environment. This equipment generates, uses, and can radiate radio frequency energy and, if not installed and used in accordance with the instruction manual, may cause harmful interference to radio communications. Operation of this equipment in a residential area is likely to cause harmful interference in which case the user will be required to correct the interference at his own expense.

This digital apparatus does not exceed the (Class A) limits for radio noise emissions from digital apparatus set out in the Radio Interference Regulations of the Canadian Department of Communications.

Le pre'sent appareil nume'rique n'emet pas de bruits radioe'lectriques de'passant les limites applicables aux appareils nume'riques (de la class A) prescrites dans le Re'glement sur le brouillage radioe'lectrique e'dicte' par le ministre des Communications du Canada.

CAUTION

Changes or modifications to this unit not expressly approved by the party responsible for compliance could void the user's authority to operate the equipment.

Determining The Ringer Equivalence Number

The REN of each line is 0.4B. The FCC requires the installer to determine the total REN for each line, and record it at the equipment.

This page remains blank intentionally.



3

Programming The DSU II System

<u>Section</u>	<u>Title</u>	<u>Page</u>
3.1	Using Chapter Three	3-7
3.2	Understanding System Programming	3-7
3.2.1	Using A Telephone To Program The System.....	3-7
3.2.2	Supporting DigiTech Telephones (Revision I And Later)	3-8
3.2.3	Converting Button Designations	3-9
3.2.4	Using A VDT To Program The System	3-11
3.2.5	Using Block Programming	3-11
3.2.6	Master Clearing The System	3-11
3.2.7	Using Programming Overlays	3-11
3.3	Master Clearing and Defaulting The System	3-12
3.3.1	Master Clearing The System	3-12
3.3.2	Defaulting The System	3-12
3.3.3	Defaulting The Lines	3-12
3.3.4	Defaulting The Stations	3-13
3.3.5	Defaulting The Button Assignments	3-13
3.3.6	Defaulting The Toll Restriction Tables	3-13
3.3.7	Programming Password Protection	3-14
3.4	System Features	3-16
3.4.1	Automatic Station Relocation.....	3-16
3.4.2	Data Baud Rate	3-17
3.4.3	Do Not Disturb (DND)	3-18
3.4.4	Exclusive Hold	3-19
3.4.5	Music On Hold	3-19
3.4.6	LCD Messaging	3-20
3.4.7	PA Port Options	3-22
3.4.8	Station Monitoring.....	3-24
3.4.9	System Alarm Reporting	3-25
3.4.10	System Clock.....	3-26
3.4.11	System Speed Dial	3-26
3.4.12	Tandem Attendant	3-28

<u>Section</u>	<u>Title</u>	<u>Page</u>
3.4.13	Tone or Voice Signaling	3-28
3.4.14	Inhibiting System Features	3-29
3.5	System Timing	3-30
3.5.1	Call Park Recall Time	3-30
3.5.2	Extended DTMF Tones For Automatic Dialing	3-31
3.5.3	Pause Time	3-32
3.5.4	Recall/Flash	3-32
3.5.5	Timed Hold Recall	3-33
3.5.6	Unanswered Call Transfer Recall Time	3-34
3.6	Line Programming	3-35
3.6.1	Abandoned Hold Release	3-35
3.6.2	Automatic Privacy	3-36
3.6.3	Line Disable	3-37
3.6.4	Line Groups	3-37
3.6.5	Line Names	3-38
3.6.6	Line Port Functions	3-40
3.6.7	Line To Line Port Re-Assignment	3-41
3.6.8	Pulse/Tone Switchable	3-42
3.6.9	Block Programming	3-43
3.6.10	Positive Disconnect Supervision	3-44
3.7	Station Features	3-45
3.7.1	Access Denied	3-46
3.7.2	All-Call and Zone Paging	3-47
3.7.3	Audible Monitoring	3-49
3.7.4	Automatic Hold	3-50
3.7.5	Automatic Privacy	3-51
3.7.6	Call Forward On Busy/Ring-No Answer	3-52
3.7.7	Call Origination Denied	3-54
3.7.8	Central Message Desk	3-54
3.7.9	Data Security Port	3-55
3.7.10	Dual Console Feature	3-55
3.7.11	Executive Override	3-56
3.7.12	Flexible Ringing Assignments	3-57
3.7.13	Flexible Station Numbering	3-60

<u>Section</u>	<u>Title</u>	<u>Page</u>
3.7.14	Group Call Pickup	3-60
3.7.15	Handset Volume Control On <i>Impact</i> Telephones.....	3-61
3.7.16	Headset Interface	3-62
3.7.17	Interactive Buttons.....	3-63
3.7.18	Idle Line Preference.....	3-64
3.7.19	Personal Ringing Tones	3-65
3.7.20	Prime Line, Prime Group, And Prime Intercom.....	3-66
3.7.21	Message Wait Originate	3-66
3.7.22	Ringing Line Preference	3-67
3.7.23	Subdued Off-Hook Voice Announce (SOHVA) Features	3-67
3.7.24	Service Observing.....	3-71
3.7.25	Station Disable.....	3-72
3.7.26	Station Name	3-72
3.7.27	Station To Station Port Reassignment	3-74
3.7.28	System Alarm Report Stations	3-75
3.7.29	Voice Announce Blocking.....	3-76
3.7.30	Block Programming.....	3-76
3.8	Button Mapping The Stations (Non-Square Configuration)	3-77
3.8.1	Account Code Button	3-78
3.8.2	Automatic Call-Back Button	3-78
3.8.3	Blank Buttons	3-79
3.8.4	Call Forward Button	3-79
3.8.5	Call Park Orbit Button	3-80
3.8.6	Do Not Disturb (DND) Button	3-80
3.8.7	DSS/BLF Button.....	3-81
3.8.8	Line Button	3-82
3.8.9	Line Group Button.....	3-82
3.8.10	Line Group Queue Button	3-83
3.8.11	Multiple Intercom Button	3-83
3.8.12	Privacy Button	3-84
3.8.13	Save Button.....	3-84
3.8.14	Voice Announce Block Button.....	3-85
3.8.15	Zone Page/All-Call Button	3-85

<u>Section</u>	<u>Title</u>	<u>Page</u>
3.9	Account Codes	3-86
3.9.1	Account Code Length	3-86
3.9.2	Account Code List	3-87
3.9.3	Enabled or Disabled Account Codes	3-88
3.9.4	Forced or Optional Entry Account Codes	3-88
3.9.5	Message Display Time For Account Codes	3-90
3.9.6	Verified Account Code Entry	3-91
3.10	The Industry-Standard Telephone Interface	3-92
3.10.1	IST Station Port Line Assignment	3-92
3.10.2	IST Distinctive Ringing	3-94
3.10.3	IST Through Dialing	3-94
3.11	Direct Department Calling	3-95
3.11.1	Access Codes For Direct Department Calling	3-96
3.11.2	Line Ports For Direct Department Calling	3-96
3.11.3	Station Ports For Direct Department Calling	3-97
3.11.4	Unanswered Call Transfer Recall Time For Direct Department Calling	3-98
3.11.5	Call Forward On Ring—No Answer	3-99
3.12	Direct Inward Station Dialing	3-100
3.12.1	Dial Time Limit	3-100
3.12.2	Inhibiting DISD Digit Dialing	3-101
3.12.3	DISD Assist Station	3-101
3.12.4	DISD Incoming Rings	3-102
3.12.5	Enable/Disable Call Waiting Tone	3-102
3.13	Data Printer Service	3-103
3.13.1	Enable Data Printer Operation	3-103
3.14	Voice Mail Interface	3-104
3.14.1	Voice Mail Port	3-105
3.14.2	Automatic Transfer of Voice Mail	3-108
3.14.3	Voice Mail Line ID	3-108
3.14.4	Voice Mail Transfer on Busy	3-109
3.14.5	Transferring Callers To Voice Mail	3-109
3.14.6	Positive Disconnect Supervision	3-110
3.14.7	Voice Mail Pause	3-110

Section	Title	Page
3.15	Versatile Voice Processing.....	3-111
3.15.1	Using Tracker Paging System With Versatile Voice Processing	3-111
3.15.2	Using Tracker For Message Notification	3-112
3.15.3	Transferring Callers To Voice Mail	3-112
3.15.4	Auto Station Logon	3-112
3.15.5	Visual Voice Mail Support	3-113
3.16	Integrated Call Costing	3-114
3.16.1	Call Costing Flow Diagram Examples	3-115
3.16.2	Exception Tables (Local Calls And Long Distance Calls)	3-121
3.16.3	Office Code Band Tables (Local Calls)	3-122
3.16.4	Zone Call Band Tables (Long Distance Calls)	3-123
3.16.5	Area Code Band Tables (Long Distance Calls).....	3-124
3.16.6	Call Rate Tables (Local And Long Distance Calls)	3-125
3.16.7	Discard Digits	3-127
3.16.8	Dialing Time And Answer Time	3-128
3.16.9	LCD Speakerphone Display Of Costed Calls.....	3-129
3.17	Specialized Route Access.....	3-130
3.17.1	Enable The SRA Feature	3-130
3.17.2	Enable SRA Office And Area Code Tables	3-131
3.17.3	Enable Special SRA Area Code Tables.....	3-133
3.17.4	Insert Digits For SRA	3-135
3.17.5	SRA Overflow Line Group.....	3-136
3.17.6	SRA Wait Time	3-137
3.18	Station Message Detail	
	Accounting/Reporting (SMDA/SMDR)	3-138
3.18.1	SMDA Department Numbers	3-139
3.18.2	SMDA Station Assignment	3-139
3.18.3	SMDA Printout	3-140
3.18.4	SMDR Printout	3-142
3.18.5	SMDA Records Deleted By The Attendant	3-143

<u>Section</u>	<u>Title</u>	<u>Page</u>
3.19	Toll Restriction Tables.....	3-144
3.19.1	Assign Entries To Toll Restriction Tables	3-145
3.19.2	Programming Toll Restriction Table Entries.....	3-146
3.19.3	Assign Toll Restriction Tables To Lines	3-147
3.19.4	Assign Toll Restriction Tables To Stations	3-147
3.19.5	Assign Toll Restriction Tables To Stations For Night Transfer (of ringing)	3-148
3.19.6	Assign Toll Restriction Tables To System Speed Dial Calls	3-148
3.19.7	Assign Toll Restriction Override (TRO) Code.....	3-149
3.19.8	Positive Disconnect Supervision	3-150
3.20	The Tracker Paging System	3-151
3.20.1	Preparing The System.....	3-152
3.20.2	Enabling The Tracker Paging System	3-152
3.20.3	Enabling The Tracker Pagers For Stations	3-153
3.20.4	Setting The Data Parameters	3-153
3.21	Digital Voice Announcing (DVA)	3-154
3.21.1	Programming For DCD Operation	3-155
3.21.2	DCD Department Transfers Before Disconnect	3-155
3.21.3	Programming For DISD Operation	3-156
3.21.4	Enabling/Disabling Digital Voice Announcing (DVA)	3-157
3.21.5	Programming The DVA Messages.....	3-158
3.22	The Data Interface Unit.....	3-160
3.22.1	Programming Data Buttons	3-160
3.22.2	Remote Data Station.....	3-161
3.22.3	Creating Data Security Groups.....	3-161
3.23	Caller ID Service Support	3-162
3.23.1	Assigning Caller ID Lines (required programming)	3-165
3.23.2	Assigning Caller ID Stations (required programming)	3-165
3.23.3	Configuring Com 2 Data Port (required programming)	3-166
3.23.4	Setting The Audible First Ring Feature (optional programming)	3-166
3.23.5	Setting The Caller ID Distribution (optional programming).....	3-167
3.23.6	Assigning A "SAVE" button (optional programming)	3-167

3.1 Using Chapter Three

Since Chapter 3 deals only with the programming of the system, each programming step includes only a brief explanation of that feature. Therefore, before you begin programming the system, familiarize yourself with all of the system's features that are discussed in Appendix A. By doing so, you can be certain that you are programming what the customer wants.

NOTE: *Prior to taking any programming action, determine all desired parameters and requirements. Record this data on the programming reference tables provided in Chapter 4.*

3.2 Understanding System Programming

While the Digital Telephone System offers many functional possibilities, it is your programming that determines the system's operation. You can program the system in two ways: using a telephone, or using a Video Display Terminal (VDT) or personal computer running communications software. The programming instructions in this manual detail the telephone programming method. The VDT programming menu is menu-driven and you can follow its on-screen directions.

3.2.1 Using A Telephone To Program The System

Perform Class of Service configuration programming from station port 10 or station port 12. The system will not accept programming commands from any other station port in the system. For best programming results, use an LCD speakerphone and a DSS/BLF console at station port 11 or 13 to see which features are assigned to individual stations. While you can install any non-LCD digital telephone and use it for programming, visual feedback of the programming operations will not be available. You must always keep the handset of the LCD speakerphone on-hook while you use this telephone to program the system.

NOTE: Be sure the system is not in the night transfer (of ringing) mode of operation when you perform the programming steps.

3.2.2 Supporting DigiTech Telephones (Revision I And Later)

There are several items that you need to consider when connecting revision I and later DigiTech telephones to the DSU II digital telephone system:

- Always program station ports to provide ringing line preference to revision I and later DigiTech telephones (and to all Impression and *Impact* telephones) that are connected there. This action is necessary to activate the orange LED feature on these telephones. The orange status light indicates a ringing line to distinguish it from lines that are in use or on hold.

3.2.3 Converting Button Designations

When you first power a new DSU II system with no telephones connected, it defaults its station ports as *Impact* 24-line speakerphones.

When you connect a telephone to a powered-up system or when you turn on the AC power to a system after you have connected a telephone to it, the system automatically button maps the telephone according to the type of software the system has. To change the button mapping default, install different software and master clear the system.

The buttons on *Impact* telephones are designated as L buttons; the buttons on DigiTech and Impression telephones are designated as A and B buttons. Table 3-1 lists each A and B button and its equivalent on an *Impact* telephone. The programming steps in this manual use A and B button designations; if you are programming from an *Impact* telephone, you must use the proper telephone programming overlay with the A and B designations. Telephone overlays are included with the literature package for the digital telephone system. You can also find sample overlays at the end of Chapter 4, Records.

Table 3-1: Impression, DigiTech And Impact Programming Buttons

Impression	DigiTech	Impact
A1	A1	L01
A2	A2	L02
A3	A3	L03
A4	A4	L04
A5	A5	L05
A6	A6	L06
A7	A7	L07
A8	A8	L08
A9	A9	L09
A10	A10	L10
A11	A11	L11
A12	A12	L12
A13	A13	L13
A14	A14	L14
A15	B9	L15
A16	B10	L16
B1	B1	L17
B2	B2	L18
B3	B3	L19
B4	B4	L20
B5	B5	L21
B6	B6	L22
	B7	L23
	B8	L24

When you perform class of service programming from stations 10 or 12 and you have placed an *Impact* telephone at the programming port, you should place the programming overlay on it.

This makes the button designations match the A and B designations called for in this system programming manual.

When button mapping using a telephone different from the telephones being programmed (cross-model button mapping), you may need either a programming overlay or Table 3–1 depending on the type of telephone installed at the programming port.

If all system telephones are the same type, when you press a button at the programming station, you select the same button on the telephone that you are mapping. No overlay or conversion chart is needed.

When you mix telephones on the same system and you are cross-model button mapping, you will need either an overlay or the conversion chart. The overlay works best when you are using an *Impact* telephone to button map an *Impression* or *DigiTech* telephone. The chart is more convenient when you are using a *DigiTech* or *Impression* telephone to button map an *Impact* telephone. In either case, when you map a line to a selected button, it is best if you choose the line by dialing its code rather than by pressing a button on the programming station to represent it. To choose lines 1 through 24, you must dial **01** through **024**.

The following examples explain when you need to use conversions.

- To select button **L21** for reprogramming on an *Impact* telephone using another *Impact* telephone at station 10 for programming, press button **L21** on the station 10 telephone. (No conversion is required in this example.)
- To select button **B5** for reprogramming on an *Impression* or *DigiTech* telephone while using an *Impact* telephone for programming, press the button designated as **B5** by the programming overlay on the *Impact* telephone at station 10 (this is actually L21 but the overlay did the conversion for you).
- To select button **L21** for reprogramming on an *Impact* telephone while using an *Impression* or *DigiTech* telephone for programming, press button **B5** on the *Impression* or *DigiTech* telephone at station 10. (You use the conversion chart to convert the B5 button to an L21 button.)

3.2.4 Using A VDT To Program The System

You can perform class of service programming using a Video Display Terminal (VDT) with an RS-232 compatible, serial interface. (You can use a personal computer running a communications software program in place of the VDT if you wish.) VDT programming is completely menu driven and easy to follow. It is arranged somewhat differently from station port programming categories to facilitate menu usage.

3.2.5 Using Block Programming

You can program a group of lines or stations to have the same configuration as one that you have already programmed. This block programming feature eliminates the need to individually program every line or station that requires the same configuration.

3.2.6 Master Clearing The System

After you have completely installed a telephone system for the first time or if a system that you previously installed has been turned off and placed out of service for a period of time (several weeks, for example), perform a master clear programming procedure before placing it into service. If you plan to perform a master clear procedure, perform it first before performing any other programming procedure. The master clear procedure clears all memory locations of any unwanted data that may be stored there. Master clearing also clears any previously programmed data, such as autodial numbers and defaults all class-of-service conditions. Therefore, never perform a master clear procedure on an existing installed system unless data loss and COS default are acceptable. Refer to the information provided in the procedure titled Master Clear for programming details.

3.2.7 Using Programming Overlays

The literature package with the system includes a programming overlay for use in identifying the buttons required for programming. The overlay fits over the buttons of the programming station. A full size copy of available programming overlays is also included at the end of Chapter 4. The overlays correspond to the programming steps listed for each feature, so when you are directed to press B1, for example, the overlay details which button is B1 for your telephone.

If you are programming the system from a VDT, it is best to allow the telephones to identify themselves to the system before you button map them. When you do this, the VDT presents the proper button designations in its prompt and you will not need an overlay or conversion chart. The system queries you to designate the telephone type for unoccupied station ports. Upon your response, the system presents the proper button designations in the prompts for these ports.

3.3 Master Clearing and Defaulting The System

You can return the entire programming configuration to the factory settings using the master clear procedure. You can also return the individual system, line, and station class of service configurations to their factory settings using the system, line, and station default procedures. The operating parameters and class of service values provided by the factory settings will provide satisfactory performance in a broad range of site applications.

CAUTION

Not only does the master clear procedure return ALL programmed variables to a known state of operation it also clears all currently stored autodial and speed dial numbers.

3.3.1 Master Clearing The System

Description: Returns entire system configuration to factory settings and clears all stored auto and speed dial numbers.

To Program:

1. Press **INTERCOM**, dial * # **7 4 6** *. "CONFIG. MODE"
2. Dial **90**. "MASTER CLEAR"
3. Dial **5 1 6 8 4** to clear the entire system.
System returns to normal operation mode automatically.

3.3.2 Defaulting The System

Description: Returns the system configuration features to factory settings.

To Program:

1. Press **INTERCOM**, dial * # **7 4 6** *. "CONFIG. MODE"
2. Dial **10**. "SYSTEM DEFAULT"
3. Press # to default system features.
System returns to configuration mode automatically.

3.3.3 Defaulting The Lines

Description: Returns the line configuration features to factory settings.

To Program:

1. Press **INTERCOM**, dial * # **7 4 6** *. "CONFIG. MODE"
2. Dial **30**. "LINE DEFAULT"
3. Press # to default line features.
System returns to configuration mode automatically.

3.3.4 Defaulting The Stations

Description: Returns the station configuration features to factory settings.

- To Program:**
1. Press **INTERCOM**, dial * # 7 4 6 *. "CONFIG. MODE"
 2. Dial **50**. "STATION DEFAULT"
 3. Dial **00** to default station ports system-wide
—OR—
select individual station port to be defaulted:
— Station 10-57 = Dial **10-57**.
 4. Dial * for next station to default
—OR—
dial * * for configuration mode or **SPEAKER** to quit.

3.3.5 Defaulting The Button Assignments

Description: Returns the button mapping of individual stations to its factory setting.

- To Program:**
1. Press **INTERCOM**, dial * # 7 4 6 *. "CONFIG. MODE"
 2. Dial **56**. "BUTTON MAPPING"
 3. Dial **01**. "BUTTON DEFAULT"
 4. Select station ports to be defaulted
—Station 10-57 = Dial **10- 57**.
 5. Dial * for next button mapping feature
—OR—
dial * * for configuration mode or **SPEAKER** to quit.

3.3.6 Defaulting The Toll Restriction Tables

Description: The system defaults two toll restriction tables with preprogrammed values and assigns them to the lines. You need only to assign them the stations to put them into effect. The preprogrammed values are as follows:

Table 1 (deny)

Entry 1 = 1

Entry 2 = 976

Entry 3 = 411

Entry 4 = 0

Table 2 (allow)

Entry 1= 1800

Entry 2 = 911

These values will provide satisfactory system performance in a broad range of site applications; however, they can be changed as needed to meet different toll restriction needs.

- To Program:**
1. Dial **70** "DEFAULT TOLL"
 2. Press # to default toll tables
 3. Dial * for configuration mode or **SPEAKER** to quit.

3.3.7 Programming Password Protection

Description: The system provides two different entry levels for programming and allows for a different password for each entry. You must use the VDT programming method to change them as needed to provide security against unauthorized program entries. The two programming entry levels are the installer level and the administrator level. You enter the installer level, using the installer password, to perform all programming functions including major changes such as master clearing or line type programming. Administrators enter the administrator level, using the administrator password, to perform most programming functions except those major changes just mentioned. You can make the two passwords different to limit access to either programming level to only certain special or authorized people. Additionally, you can construct a password that will prevent all COS programming entry from station 10.

Default Passwords

The default passwords are detailed in the following list:

VDT Installer	I*nnn* (nnn = 746)
VDT Administrator	I*nnn* (nnn = 236)
Station 10 Installer	INTERCOM *#nnn* (nnn = 746)
Station 10 Administrator	INTERCOM *#nnn* (nnn = 236)

Customized Passwords

Customized passwords can be alpha-numeric or numeric only (no spaces allowed) and must contain six characters. To retain the ability to enter programming from station 10, you must maintain the I*nnn* format in the VDT password and you must enter only numbers in the nnn entry; however, you must not enter a zero for the leading **n**.

Once you customize a password, it remains customized and you must use the new password to gain entry into the system for future programming tasks. Neither default nor master clear will erase the customized password. It is very important that you keep a hard copy of the customized password since it provides the only entry to system COS programming through either the VDT or station 10. If no one can remember the customized password, Comdial's Technical Services Department can provide emergency entry *but it charges a fee for this service*. Otherwise, you must disconnect all AC power and any battery back-up equipment, wait an extended period of time (up to several weeks) for the internal memory protection to completely discharge, and reprogram the system using the default password to gain entry.

NOTE: *Password protection programming is a Video Display Terminal feature only. You can not customize a password using station 10 programming entry.*

- To Program:**
1. From keyboard, type **I*746*** for the programming mode.
 2. From main COS programming menu,
—type **6** to change installer password
—OR—
—type **7** to change administrator password and press **RETURN**.
 3. At menu prompt, type customized password using any six alpha-numeric or numeric only characters.

*NOTE: To retain the ability to enter programming from station 10, you must maintain the I*nnn* format in the VDT password and you must enter only numbers in the nnn entry; however, you must not enter a zero for the leading n.*

4. As directed by next menu prompt, repeat step 3 to ensure that you entered correct code.
5. When finished, return to main menu and log out of programming.

3.4 System Features

Configuring the system means that you are setting the parameters that will be true system-wide. You should make a record in Chapter 4 of all programming decisions that you make—it will help you keep track of what you have done and will help you troubleshoot any problem that might arise later.

NOTE: *A lighted LED next to the programming button for the selection indicates the current configuration. When a single button provides a toggle (on/off) action, the lighted LED indicates the active feature.*

The first step in any programming sequence is to enter the base level. Once in this mode, you can dial the feature code for any desired configuration. Enter the base level with the following procedure: press **INTERCOM** then dial ***# 7 4 6***. When you want to end the programming, press the **SPEAKER** button to end the programming procedure and return the system to normal operation.

3.4.1 Automatic Station Relocation

Description: With this feature, the system will automatically recognize a particular station should that station be re-located to a different station port. The system will supply the same COS parameters at this new port as was programmed for the station at the original port. This feature allows users to relocate their telephone from one station port location to another yet retain their original telephone features.

NOTE: *If you turn this feature on, be sure to make the station users understand that their telephone parameters could change if they trade telephones from port to port. If you want automatic relocation to take place, do nothing and wait for the light to turn off on its own, or press the **HOLD** button to immediately accept the relocation. If you do not want automatic relocation to take place, press the **#** button while the message waiting light is flashing.*

To Program:

1. Dial **27**. “*AUTO STA RELOCAT*”
2. Press **A1** to toggle between enable and disable (LED On = Enable)
—OR—
dial **1** to Enable (A1 LED On)
dial **2** to Disable.
3. Dial ***** for configuration mode.

To change setting, repeat procedure and make opposite selection.

3.4.2 Data Baud Rate

Description: The speed or baud rate of the data bit stream, which carries the SMDR and configuration data between the system and an external data device, must be programmed to match the requirements of the data device.

NOTE: *If you use XMODEM protocol for data transfer between a PC and the common equipment, you must use 8-bit data.*

- To Program:**
1. Dial **15**. *“BAUD RATE”*
 2. Dial code for serial data port to be programmed:
 Dial **1** for COM 1,
 Dial **2** for COM 2,
 Dial **3** for COM 3,
 Dial **4** for COM 4.
 3. Choose baud rate

—Dial 01 or Press A1	<i>“W nD nS 110”</i>
—Dial 02 or Press A2	<i>“W nD nS 150”</i>
—Dial 03 or Press A3	<i>“W nD nS 300 ”</i>
—Dial 04 or Press A4	<i>“W nD nS 600”</i>
—Dial 05 or Press A5	<i>“W nD nS 1200”</i>
—Dial 06 or Press A8	<i>“W nD nS 2400”</i>
—Dial 07 or Press A9	<i>“W nD nS 4800”</i>
—Dial 08 or Press A10	<i>“W nD nS 9600”</i>
—Dial 09 or Press A11	<i>“W nD nS 19200”</i>
—Dial 10 or Press A7 for 7 data bits and 2 stop bits	<i>“W 7D 2S ZZZZZ”</i>
—Dial 11 or Press A14 for 8 data bits and 1 stop bit.	<i>“W 8D 1S ZZZZZ”</i>
 4. Dial * for next data port.
 5. Dial * * for configuration mode.
- To change setting, repeat procedure and make opposite selection.

3.4.3 Do Not Disturb (DND)

All of the following features are part of the Do Not Disturb (DND) application.

Do Not Disturb Button

Description: A telephone user can press a button (either one that you have mapped on that station or one that is provided by an interactive button on an LCD speakerphone) to set the station to a DND condition.

- To program:**
1. Dial **56**. *“BUTTON MAPPING ”*
 2. Dial **07**. *“ASSIGN DND CODE ”*
 3. Select button to be programmed
—Press **A1–A14, B1–B10**.
 4. Select station ports to be programmed with a DND button:
— Station 10–57 = Dial **10—57**, or press **C10–C57**.
 5. Dial * for further DND button assignment
—OR—
dial * * for next button mapping feature
—OR—
dial * * * for configuration mode.

To clear, dial **5604**, press button, dial # and repeat steps 4 and 5.

Do Not Disturb Inhibit

Description: You can inhibit the ability to set DND on a system-wide basis.

- To Program:**
1. Dial **19**. *“DND XXXXXXXX ”*
 2. Press **A1** to toggle between Enable and Disable (LED On = Enable)
—OR—
dial **1** to Enable (A1 LED On) *“DND ENABLED ”*
dial **2** to Disable. *“DND DISABLED ”*
 3. Dial * for configuration mode.

To change setting, repeat procedure and make opposite selection.

Do Not Disturb Override Capability

Description: A caller to a DND station can override a DND condition when you program the calling station to have the DND override feature.

- To Program:**
1. Dial **53**. *“STATION FEATURES”*
 2. Dial **03**. *“DND OVERRIDE”*
 3. Select station ports to be programmed
—Station 10–57 = Dial **10–57**, or press **C10–C57**.
 4. Dial * for next station feature
—OR—
dial * * for configuration mode.

To change setting, repeat procedure and make different selection.

3.4.4 Exclusive Hold

Description: This feature prevents a telephone user at one station from picking up a call that a user placed on hold at another station. You can enable or disable it system-wide using this procedure.

- To Program:**
1. Dial **23**. *“XXXXXXXX EXC HOLD”*
 2. Press **A1** to toggle between enable and disable (LED On = Enable)
—OR—
dial **1** to Enable (A1 LED On) *“ENABLE EXC HOLD”*
dial **2** to Disable. *“DISABLE EXC HOLD”*
 3. Dial * for configuration mode.

To change setting, repeat procedure and make opposite selection.

3.4.5 Music On Hold

Description: When you connect an external music source to the system, it will provide music to outside lines that are placed on hold. You can disable the music using this programming procedure. System attendants also have access to this feature

- To Program**
1. Press **04**. *“MOH XXXXXXXX”*
 2. Press **A1** to toggle between enable and disable (LED On = Enabled)
—OR—
dial **1** to Enable (A1 LED on) *“MOH ENABLED”*
dial **2** to Disable. *“MOH DISABLED”*
 3. Dial * for configuration mode.

To change setting, repeat procedure and make opposite selection.

3.4.6 LCD Messaging

Description: You can create messages that telephone users can set at their stations to be displayed by any LCD speakerphone that calls them on the intercom line. The system provides two standard messages but you can use this programming procedure to create up to 10 custom messages. System attendants also have access to this feature, but they must use station 10 or 12 to program messages.

- To Program:**
1. Dial **05**. *"LCD MESSAGES "*
 2. Dial **1-0** for message number. *"XXXX... "*
 3. Dial **#** to clear current message.
 4. Refer to the character code table, and compose message (maximum 16 characters).
 5. Dial two-digit codes to create message. *"YYYYYYY... "*
 —OR—
 dial **10** for pre-programmed message *"BACK AT "*
 —OR—
 dial **20** for pre-programmed message. *"CALL"*
 6. Dial ***** for next message location and repeat steps 2-5.
 7. Dial ****** for configuration mode.

Character Code Table

Character	Code	Character	Code	Character	Code
A	21	a	24	Space	12
B	22	b	25	-	15
C	23	c	26	;	17
D	31	d	34	/	18
E	32	e	35	“	19
F	33	f	36	.	27
G	41	g	44	,	28
H	42	h	45	:	29
I	43	i	46	1	01
J	51	j	54	2	02
K	52	k	55	3	03
L	53	l	56	4	04
M	61	m	64	5	05
N	62	n	65	6	06
O	63	o	66	7	07
P	71	p	74	8	08
Q	11	q	14	9	09
R	72	r	75	0	00
S	73	s	76		
T	81	t	84		
U	82	u	85		
V	83	v	86		
W	91	w	94		
X	92	x	95		
Y	93	y	96		
Z	13	z	16		

3.4.7 PA Port Options

The common equipment includes a special paging port that you can use to couple the system to a customer-supplied external paging amplifier. The following section details the programming features for the paging port.

Ringling Type

Description: You can assign lines to the PA port for direct ring, delayed ring, or night transfer (of ringing).

- To Program:**
1. Dial **60**. *“P.A. OPTIONS ”*
 2. Choose ringing assignment
 - Dial **1** for direct ring *“DIRECT RING”*
 - Dial **2** for delay ring *“DELAY RING”*
 - Dial **3** for night ring. *“NIGHT RING”*
 3. Select line ports
 - Line port 1–14 = Dial **01–14** or press **A1– A14**
 - Line port 15, 16 = Dial **15, 16** or press **B1, B2**
 - Line port 17–24 = Dial **17–24** or press **HOLD** then press **A1–A8**.

NOTE: *LEDs turn on when the line is assigned.*

4. Dial * for next PA option
 - OR—
 - dial * * for configuration mode.

To change setting, repeat procedure and make opposite selection.

Zone Paging

Description: You can also assign zone or all-call paging to the PA port.

- To Program:**
1. Dial **60**. *“P.A. OPTIONS ”*
 2. Dial **4** to assign zone paging. *“P.A. ZONES ”*
 3. Choose zone.
 - Press **A1** or dial **1** for zone 1
 - Press **A2** or dial **2** for zone 2
 - Press **A3** or dial **3** for zone 3
 - Press **A4** or dial **4** for all-call.

NOTE: *A1, A2, A3, or A4 LED turns on when a zone is assigned.*

4. Dial * for next PA option
 - OR—
 - dial * * for configuration mode.

To change setting, repeat procedure and make different selection.

Ringling Relay Tracking

Description: You can select the tracking source for the ringing relay to be either station 17 ringing or the ringing that you have assigned to the paging port. Making it track the ringing that you have assigned to the PA port provides relay control for the customer-supplied PA amplifier if needed.

- To Program:**
1. Dial **60**. *“P.A. PORT ”*
 2. Dial **5**. *“RELAY XXXXXXXX”*
 3. Choose relay tracking assignment
 - Press **A1** to toggle between paging port and station port 17 (LED On = paging port)
 - OR—
 - dial **1** for station port 17 *“RELAY STA. 17”*
 - dial **2** for paging port. *“RELAY P.A. PORT”*
 4. Dial ***** for next PA option
 - OR—
 - dial ****** for configuration mode.

To change setting, repeat procedure and make different selection.

Ringling Tones

Description: You can choose between the intercom tone and the DTMF tone for these PA port ringing tones. The intercom tone provides a soft tone and the DTMF provides a loud tone.

- To Program:**
1. Dial **60**. *“P.A. PORT ”*
 2. Dial **6**. *“P.A. XXXX TONE ”*
 3. Choose tone assignment
 - Press **A1** to toggle between intercom and DTMF tone (LED On = Intercom Tone)
 - OR—
 - Dial **1** for Intercom tone *“P.A. ITCM TONE ”*
 - Dial **2** for DTMF tone. *“P.A. DTMF TONE ”*

4. Dial ***** for next PA option
 - OR—
 - Dial ****** for configuration mode.
- To change setting, repeat procedure and make different selection.

3.4.8 Station Monitoring

You can enable two types of station monitoring: visual ring indication and audible monitoring.

Visual Ring Indication

Description: The DSS/BLF at a station provides idle, busy, and ringing status of all of the monitored stations. If users deem the flashing BLF lights associated with visual ring indication distracting, you can disable this visual indication system-wide using this procedure.

- To Program:**
1. Dial **20**. *“MONITOR XXXXXXXX”*
 2. Press **A1** to toggle between enable and disable (LED On = Enable)
—OR—
—dial **1** to Enable (A1 LED = On) *“MONITOR ENABLED”*
—dial **2** to Disable. *“MONITOR DISABLED”*
 3. Dial ***** for configuration mode.

To change setting, repeat procedure and make opposite selection.

Audible Monitoring (Station Monitoring)

Description: If you enable this visual ring indication, you can also enable audible indication of both direct and delayed ringing on a per-station basis if you wish.

- To Program:**
1. Dial **53**. *“STATION FEATURES”*
 2. Dial **20**. *“AUDIBLE MONITOR ”*
 3. Dial **1** for no audible monitoring. *“NONE”*
Dial **2** for direct ring monitoring *“DIRECT RING”*
Dial **3** for delayed ring monitoring. *“DELAYED RING”*
 4. Select stations for programming:
—Station 10-57 = Dial **10- 57**, or press **C10-C57**.
 5. Dial ***** next monitoring condition
—OR—
dial ****** for next station feature
—OR—
Dial ******* for configuration mode.

To change setting, repeat procedure and make different selection.

3.4.9 System Alarm Reporting

The system can send special codes that convey certain system alarm conditions to selected stations where they will show on their LCD displays.

System Alarm Report Enabling

Description: Enable the system alarm reporting on a system-wide basis using this feature.

- To Program:**
1. Dial **28**. *“ALARM REPORTS”*
 2. Press **A1** to toggle between enable and disable (LED On = Enable).
—OR—
dial **1** to enable *“MONITOR ENABLED”*
dial **2** to disable. *“MONITOR DISABLED”*
 3. Dial ***** for configuration mode.
- To change setting, repeat procedure and make different selection.

System Alarm Report Stations

Description: Enable the system alarm reporting on the desired stations using this feature.

- To Program:**
1. Dial **53**. *“STATION FEATURES”*
 2. Dial **28**. *“ALARM RECEIVE”*
 3. Select station ports for programming
—Station 10-57 = Dial **10-57**, or press **C10-C57**.
 4. Dial ***** for next station feature
—OR—
dial ****** for configuration mode.
- To change setting, repeat procedure and make different selection.

3.4.10 System Clock

Description: The system clock maintains current date and time information. The system provides this information to LCD speakerphones for display. Set the system time with this feature. The system attendant also has access to this feature.

- To Program:**
- | | |
|---|--|
| <ol style="list-style-type: none"> 1. Dial 01.
 <u>Long Form</u>
 —Dial 00-99 for yr.
 —Dial 01-12 for mo.
 —Dial 01-31 for day
 —Dial 00-23 for hr.
 —Dial 00-59 for min. 2. Dial * for configuration mode. <p>To change setting, repeat procedure and make different selection.</p> | <p>“<i>SET CLOCK</i>”</p> <p><u>Short Form</u>
 —Dial 00-23 for hr.
 —Dial 00-59 for min.
 —Dial # to assign hours and minutes</p> |
|---|--|

3.4.11 System Speed Dial

Description: The system speed dial is a system-wide list of numbers that all users can access for automatic dialing. Those users with two-line display LCD speakerphones can scroll through the list of names that you assign to the system speed dial numbers using their speakerphone’s display. After scrolling through the list, they can pick the name they wish to call, and automatically dial the number assigned to the name. The system scrolls this index of names in the sequence that you or the attendant sorted the entries; therefore, be sure to arrange the entries in a sequence that best meets the system user’s needs.

- To Program:**
- | | |
|---|--|
| <ol style="list-style-type: none"> 1. Dial 02. 2. Dial 01-99 for storage location. 3. Dial # to clear current entry. 4. Choose line, line group, or intercom to be used with speed dial number.
 —Line port 1-14 = Dial 01-14 or press A1-A14.
 —Line port 15, 16 = Dial 15, 16 or press B1, B2.
 —Line port 17-24 = Dial 17-24 or press HOLD, A1-A8.
 —Dial 90 for last line used or prime line.
 —Dial 91-94 for line group 1-4.
 —Press ITCM button for intercom line. 5. Dial number for storage (32 digits max).
 —If required, press HOLD button to store a pause.
 —If required, press TAP button to store a hookflash. 6. Press T/C button to program name. 7. Enter digits from character chart on the next page to spell name (up to 16 characters).
 —OR—
 Press T/C button to leave name blank. | <p>“<i>SYS SPEED DIAL</i>”</p> <p>“XXXXXXXXX...”</p> <p>“<i>LINE:</i>”</p> <p>“<i>LINE XX</i>”</p> <p>“<i>PRIME LINE</i>”</p> <p>“<i>LINE GROUP 1</i>”</p> <p>“XXXXX...”</p> |
|---|--|

8. Press **T/C** button to save the number and name.
9. Repeat steps 2-9 for all speed dial numbers.
—OR—
Press * for configuration mode.

Upper Case Character Chart	
Character	Code
A	21
B	22
C	23
D	31
E	32
F	33
G	41
H	42
I	43
J	51
K	52
L	53
M	61
N	62
O	63
P	71
Q	11
R	72
S	73
T	81
U	82
V	83
W	91
X	92
Y	93

Lower Case Character Chart	
Character	Code
a	24
b	25
c	26
d	34
e	35
f	36
g	44
h	45
i	46
j	54
k	55
l	56
m	64
n	65
o	66
p	74
q	14
r	75
s	76
t	84
u	85
v	86
w	94
x	95
y	96
z	16

Symbol And Number Character Chart	
Character	Code
SPACE	12
;	17
/	18
“	19
.	27
,	28
:	29
1	01
2	02
3	03
4	04
5	05
6	06
7	07
8	08
9	09

3.4.12 Tandem Attendant

Description: When you enable this feature, a recall from an unanswered call transfer or timed hold recall will ring at both attendant stations. When you disable it, only the attendant station that transferred the call will ring.

To Program:

1. Dial **24**. *“TANDEM ATTN XXX ”*
2. Press **A1** to toggle between enable and disable (LED On = Enable)
—OR—
dial **1** to Enable (A1 LED is on) *“TANDEM ATTN ON”*
dial **2** to Disable. *“TANDEM ATTN OFF ”*
3. Dial ***** for configuration mode.

To change setting, repeat procedure and make different selection.

3.4.13 Tone or Voice Signaling

Description: Intercom calls can be tone signaled or voice signaled. Use this programming feature to select the system’s signaling choice. With either method set as the system’s first choice, the user can choose the other method as needed.

To Program:

1. Dial **16**. *“XXXXXX ANN. FIRST”*
2. Press **A1** to toggle between Voice To Tone (LED On = voice signaling)
—OR—
dial **1** for Voice First *“VOICE ANN. FIRST”*
dial **2** for Tone First. *“TONE ANN. FIRST”*
3. Dial ***** for configuration mode.

To change setting, repeat procedure and make different selection.

3.4.14 Inhibiting System Features

Description: You can disable certain features system-wide to prevent unauthorized users from tampering with the system. You can performing the system default procedure to re-enable features that you disable with this feature inhibit procedure.

- To Program:**
1. Dial 29. *“FEATURE INHIBIT”*
 2. Select feature.
 - Dial 01 to disable Line Group 1
 - Dial 02 to disable Line Group 2
 - Dial 03 to disable Line Group 3
 - Dial 04 to disable Line Group 4
 - Dial 05 to disable Zone 1 Paging
 - Dial 06 to disable Zone 2 Paging
 - Dial 07 to disable Zone 3 Paging
 - Dial 08 to disable All Call
 - Dial 09 to disable Meet Me Page
 - Dial 10 to disable Night Transfer
 - Dial 11 to disable Background Music
 - Dial 12 to disable Voice Announce Block
 - Dial 13 to disable Message Waiting
 - Dial 14 to disable Call Pickup
 - Dial 15 to disable Call Forward
 - Dial 16 to disable Automatic Call Back
 - Dial 17 to disable Station-to-Station Messaging
 - Dial 18 to disable Line Group Queue
 - Dial 19 to disable Directed Station Hold
 - Dial 20 to disable Call Park orbit 1
 - Dial 21 to disable Call Park orbit 2
 - Dial 22 to disable Call Park orbit 3
 - Dial 23 to disable Call Park orbit 4
 - Dial 24 to disable Call Park orbit 5
 - Dial 25 to disable Call Park orbit 6
 - Dial 26 to disable Call Park orbit 7
 - Dial 27 to disable Call Park orbit 8
 - Dial 28 to disable Call Park orbit 9
 - Dial 29 to disable Call Waiting
 - Dial 30 to disable LCD Messaging
 - Dial 31 to disable Executive Override/Service Observing
 - Dial 32 to disable Account Code
 - Dial 33 to disable Personal Call Forward
 - Dial 34 to enable all features
 - Dial * for next item
 - Dial * * for configuration mode.

3.5 System Timing

The digital telephone system has several attributes that control timing dimensions of system operation. The following features set these various timing attributes.

3.5.1 Call Park Recall Time

Description: A call that remains in a parking orbit for a programmed length of time automatically returns to a timed hold recall condition at the parking station. Set the call park recall time with this programming feature.

- To Program:**
1. Dial **22**. *“C.P. RECALL X”*
 2. Select recall time (program button LED On = Selected Time)
 - Dial **1** or press **A1** = 1 min *“C.P. RECALL 1”*
 - Dial **2** or press **A2** = 2 min *“C.P. RECALL 2”*
 - Dial **3** or press **A3** = 3 min *“C.P. RECALL 3”*
 - Dial **4** or press **A4** = 4 min *“C.P. RECALL 4”*
 - Dial **5** or press **A5** = 5 min *“C.P. RECALL 5”*
 - Dial **6** or press **A8** = 6 min *“C.P. RECALL 6”*
 - Dial **7** or press **A9** = Never Recall. *“NEVER RECALL”*
 3. Dial ***** for configuration mode.

To change setting, repeat procedure and make different selection.

3.5.2 Extended DTMF Tones For Automatic Dialing

Description: When a telephone user dials a number automatically (autodial, saved number redial, etc), the duration of the generated DTMF tones are as you set them with this programming option. This feature is useful when automatically dialed numbers access answering machines, banking computers, or voice mail, for example, that require DTMF tones that are longer than standard tones.

- To Program:**
1. Dial **26**. *“DTMF DIALNG XXXX”*
 2. Choose DTMF tone length
 - Dial **01** or press **A1** = 60 msec *“DTMF DIALNG 60”*
 - Dial **02** or press **A2** = 80 msec *“DTMF DIALNG 80”*
 - Dial **03** or press **A3** = 100 msec *“DTMF DIALNG 100”*
 - Dial **04** or press **A4** = 120 msec *“DTMF DIALNG 120”*
 - Dial **05** or press **A5** = 160 msec *“DTMF DIALNG 160”*
 - Dial **06** or press **A6** = 240 msec *“DTMF DIALNG 240”*
 - Dial **07** or press **A7** = 320 msec *“DTMF DIALNG 320”*
 - Dial **08** or press **A8** = 400 msec *“DTMF DIALNG 400”*
 - Dial **09** or press **A9** = 480 msec *“DTMF DIALNG 480”*
 - Dial **10** or press **A10** = 560 msec *“DTMF DIALNG 560”*
 - Dial **11** or press **A11** = 720 msec *“DTMF DIALNG 720”*
 - Dial **12** or press **A12** = 880 msec *“DTMF DIALNG 880”*
 - Dial **13** or press **A13** = 1040 msec *“DTMF DIALNG 1040”*
 3. Dial ***** for configuration mode.

To change setting, repeat procedure and make different selection.

3.5.3 Pause Time

Description: During auto dials and speed dials, it is sometimes necessary to delay the sending of digits to give switching equipment time to prepare for receiving them. A pause is stored for this purpose whenever the user presses the **HOLD** button. You can set the length of the pause with this programming feature.

- To Program:**
- | | |
|--------------------------------------|--------------------------|
| 1. Dial 13 . | <i>“PAUSE TIME XXX”</i> |
| 2. Select time. | |
| —Dial 1 or Press A1 | <i>“PAUSE TIME 0.50”</i> |
| —Dial 2 or Press A2 | <i>“PAUSE TIME 1”</i> |
| —Dial 3 or Press A3 | <i>“PAUSE TIME 1.50”</i> |
| —Dial 4 or Press A4 | <i>“PAUSE TIME 2”</i> |
| —Dial 5 or Press A5 | <i>“PAUSE TIME 3”</i> |
| —Dial 6 or Press A8 | <i>“PAUSE TIME 5”</i> |
| —Dial 7 or Press A9 | <i>“PAUSE TIME 7.50”</i> |
| —Dial 8 or Press A10 | <i>“PAUSE TIME 10”</i> |
| —Dial 9 or Press A11 | <i>“PAUSE TIME 15”</i> |
| —Dial 0 or Press A12 . | <i>“PAUSE TIME 20”</i> |
| 3. Dial * for configuration mode. | |
- To change setting, repeat procedure and make different selection.

3.5.4 Recall/Flash

Description: The system can generate either a line disconnect (recall) or a host system feature access signal (flash) depending upon the programmed time.

- To Program:**
- | | |
|--------------------------------------|---------------------------|
| 1. Dial 12 . | <i>“RECALL/FLSH XXXX”</i> |
| 2. Select time. | |
| —Dial 1 or Press A1 | <i>“RECALL/FLSH 0.08”</i> |
| —Dial 2 or Press A2 | <i>“RECALL/FLSH 0.30”</i> |
| —Dial 3 or Press A3 | <i>“RECALL/FLSH 0.50”</i> |
| —Dial 4 or Press A4 | <i>“RECALL/FLSH 0.60”</i> |
| —Dial 5 or Press A5 | <i>“RECALL/FLSH 0.75”</i> |
| —Dial 6 or Press A8 | <i>“RECALL/FLSH 0.88”</i> |
| —Dial 7 or Press A9 | <i>“RECALL/FLSH 1”</i> |
| —Dial 8 or Press A10 | <i>“RECALL/FLSH 1.50”</i> |
| —Dial 9 or Press A11 | <i>“RECALL/FLSH 2”</i> |
| —Dial 0 or Press A12 . | <i>“RECALL/FLSH 3”</i> |
| 3. Dial * for configuration mode. | |
- To change setting, repeat procedure and make different selection.

3.5.5 Timed Hold Recall

Description: After a call has been on hold for a programmed length of time, the system will recall the station that placed the call on hold. Set the hold recall time with this programming procedure.

- To Program:**
1. Dial **14**. *“HOLD RECALL XXX”*
 2. Select time
 - Dial **1** or Press **A1** *“HOLD RECALL 30”*
 - Dial **2** or Press **A2** *“HOLD RECALL 60”*
 - Dial **3** or Press **A3** *“HOLD RECALL 90”*
 - Dial **4** or Press **A4** *“HOLD RECALL 120”*
 - Dial **5** or Press **A5** *“HOLD RECALL 180”*
 - Dial **6** or Press **A8** *“HOLD RECALL 240”*
 - Dial **7** or Press **A9** *“HOLD RECALL 300”*
 - Dial **8** or Press **A10** *“HOLD RECALL 360”*
 - Dial **9** or Press **A11** *“HOLD RECALL 420”*
 - Dial **0** or Press **A12**. *“HOLD RECALL 0”*
 3. Dial ***** for configuration mode.
To change setting, repeat procedure and make different selection.

3.5.6 Unanswered Call Transfer Recall Time

Description: A transferred call that remains unanswered after a programmed length of time will return to the transferring station for answering. Set the transfer recall time with this programming procedure.

- To Program:**
1. Dial **11**. *“TRANSFER RECALL ”*
 2. Dial **1** (station transfer recall) *“STA XFR RCL XXX ”*
 — OR —
 dial **2** (department transfer recall). *“DEPT XFR RCL XXX”*
 3. Choose transfer time.

—Dial 1 or Press A1	<i>“STA XFR RCL 10”</i>
—Dial 2 or Press A2	<i>“STA XFR RCL 20”</i>
—Dial 3 or Press A3	<i>“STA XFR RCL 25”</i>
—Dial 4 or Press A4	<i>“STA XFR RCL 30”</i>
—Dial 5 or Press A5	<i>“STA XFR RCL 45”</i>
— Dial 6 or Press A8	<i>“STA XFR RCL 60”</i>
—Dial 7 or Press A9	<i>“STA XFR RCL 90”</i>
—Dial 8 or Press A10	<i>“STA XFR RCL 120”</i>
— Dial 9 or Press A11	<i>“STA XFR RCL 180”</i>
—Dial 0 or Press A12 .	<i>“STA XFR RCL 400”</i>
 4. Press * for next transfer recall feature.
 5. Press * * for configuration mode.
- To change setting, repeat procedure and make different selection.

3.6 Line Programming

By using line configuration, you can program the parameters for individual lines. The programming decisions you make for a particular line will only be true for that line and not for the entire telephone system. You should make a record in Chapter 4 of all programming decisions that you make—it will help you keep track of what you have done and will help you troubleshoot any problem that might arise later.

NOTE: *A lighted LED next to the programming button for the selection indicates the current configuration. When a single button provides a toggle (on/off) action, the lighted LED indicates the active feature.*

The first step in any programming sequence is to enter the base level. Once in this mode, you can dial the feature code for any desired configuration. Enter the base level with the following procedure: press **INTERCOM** then dial ***#746***. The last step is to press the **SPEAKER** button to end the programming procedure and return the system to normal operation.

To make a line port selection, press a programming button or dial a selection number on the keypad as detailed in the following chart.

Table 3-3: Line Port Codes

LINE	PROG. BUTTONS	KEYPAD BUTTONS
1-14	A1-A14	01-14
15, 16	B1, B2	15, 16
17-24	HOLD plus A1-A8	17- 24

3.6.1 Abandoned Hold Release

Description: When a distant party abandons a hold condition and disconnects from a line (hangs up), the central office will send a forward disconnect signal to the digital telephone system. This signal can be either 50 ms. or 350 ms. in length. Find out from the telephone company what the signal length is, and program the all of the central office line ports to match it using this programming procedure.

- To Program:**
1. Dial **38**. *“HOLD RELEASE 50 ”*
 2. Select hold release time for line ports (LED On = 50 msec).
 - Line port 1-14 = Dial **01-14** or press **A1-A14**
 - Line port 15, 16 = Dial **15, 16** or press **B1, B2**
 - Line port 17-24 = Dial **17- 24** or press **HOLD** then press **A1-A8**.
 3. Dial ***** for configuration mode.

To change setting, repeat procedure and make different selection.

3.6.2 Automatic Privacy

You can make a line private or non-private. In the private mode, a station has exclusive use of a line during a call. Lines are private unless you re-program them and make them non-private.

Private Or Non-Private Lines

Description: Use this programming feature to set which lines are private or non-private.

- To Program:**
1. Dial **40**. *“PRIVACY RELEASE”*
 2. Select line ports to be non-private (LED On = Non Private)
 - Line port 1–14 = Dial **01–14** or Press **A1–A14**
 - Line port 15, 16 = Dial **15, 16** or press **B1, B2**
 - Line port 17–24 = Dial **17– 24** or press **HOLD** then press **A1–A8**.
 3. Dial * for configuration mode.

To change setting, repeat procedure and make different selection.

Automatic Privacy Release

Description: You can arrange for individual station to automatically release privacy while on certain lines. With this arrangement, other stations can join that particular station whenever it is on the privacy release line.

- To Program:**
1. Dial **54**. *“STA/LINE CONFIG.”*
 2. Dial **4**. *“PRIVACY RELEASE”*
 3. Select line ports:
 - Line port 1–14 = Dial **01–14** or Press **A1– A14**.
 - Line port 15, 16 = Dial **15, 16** or press **B1, B2**.
 - Line port 17–24 = Dial **17– 24** or press **HOLD** then press **A1–A8**.
 4. Dial # when all line ports are selected.
 5. Select station ports to be programmed
 - Station 10–57 = Dial **10–57**, or press **C10–C57**.
 6. Dial * when all station ports are selected
 - OR—
 - dial * * for next station/line feature
 - OR—
 - dial * * * for configuration mode.

To change setting, repeat procedure and make different selection.

3.6.3 Line Disable

Description: You can take a line port out of service when necessary (because of defect or some other reason) using this programming procedure.

- To Program:**
1. Dial **31**. *“DISABLE LINES”*
 2. Select line ports to be disabled.
 - Line port 1–14 = Dial **01–14** or Press **A1–A14**
 - Line port 15, 16 = Dial **15, 16** or press **B1, B2**
 - Line port 17–24 = Dial **17– 24** or press **HOLD** then press **A1–A8**.
 3. Dial * for configuration mode.

To enable a disabled line, use the procedure described in section 3.6.6, *Line Port Functions*, and program it as a central office line.

3.6.4 Line Groups

Description: Group outside lines of the same type together for dial-up outgoing access. Access codes for the line groups are as follows:

- Group 1 = Dial **9**
- Group 2 = Dial **81**
- Group 3 = Dial **82**
- Group 4 = Dial **83**.

NOTE: *When you perform this procedure, the system automatically arranges itself for hybrid operation. Remember, hybrid operation may incur a higher monthly tariff than what the key system operation incurs. Ask the local telephone company for details.*

- To Program:**
1. Dial **35**. *“ASSIGN LINE GRPS”*
 2. Dial 0 for no groups assigned *“NO LINE GROUP”*
 - OR—
 - Dial **1** for Line Group 1 *“LINE GROUP 1”*
 - Dial **2** for Line Group 2 *“LINE GROUP 2”*
 - Dial **3** for Line Group 3 *“LINE GROUP 3”*
 - Dial **4** for Line Group 4. *“LINE GROUP 4”*
 3. Select line ports to be assigned (LED On = Lines Assigned).
 - Line port 1–14 = Dial **01–14** or press **A1–A14**
 - Line port 15–16 = Dial **15–16** or press **B1–B2**
 - Line port 17–24 = Dial **17–24** or press **HOLD** then press **A1–A8**.
 4. Dial * for next group
 - OR—
 - dial ** for next feature
 - OR—
 - dial * * for configuration mode.

To change the settings, repeat procedure and make different selections.

3.6.5 Line Names

Description: You can name lines as to their function to identify them for use. Names such as WATTS, CO, etc., when appearing on the LCD speakerphone displays, make locating a desired line easier for the station user to do. A line name can contain up to five characters. See the chart on the following page for the line-name characters.

- To Program:**
1. Dial **34**. *“LINE NAME”*
 2. Select line ports to be assigned
 - Line port 1–14 = Dial **01–14** or press **A1–A14**
 - Line port 15, 16 = Dial **15, 16** or press **B1, B2**
 - Line port 17–24 = Dial **17– 24** or press **HOLD** then press **A1–A8**.
 3. Press **#** to clear current name.
 4. Dial line name character codes (5 characters maximum for each line port from the character code table shown on the next page—each character is represented by two digits).
 - Examples: —WATTS = Dial **91 21 81 81 73**
 - 0156 = Dial **00, 01, 05, 06**
 5. Dial ***** and repeat last three steps for next line
 - OR—
 - dial ****** for configuration mode.

To change setting, repeat procedure and make different selection.

Character Code Table

Character	Code	Character	Code	Character	Code
A	21	a	24	Space	12
B	22	b	25	-	15
C	23	c	26	;	17
D	31	d	34	/	18
E	32	e	35	“	19
F	33	f	36	.	27
G	41	g	44	,	28
H	42	h	45	:	29
I	43	i	46	1	01
J	51	j	54	2	02
K	52	k	55	3	03
L	53	l	56	4	04
M	61	m	64	5	05
N	62	n	65	6	06
O	63	o	66	7	07
P	71	p	74	8	08
Q	11	q	14	9	09
R	72	r	75	0	00
S	73	s	76		
T	81	t	84		
U	82	u	85		
V	83	v	86		
W	91	w	94		
X	92	x	95		
Y	93	y	96		
Z	13	z	16		

3.6.6 Line Port Functions

You can set individual line ports to function as auxiliary line ports, for a paging amplifier, for example, or to function with standard CO lines.

Auxiliary Lines

Description: You can condition a line port to serve as a port for an external paging amplifier.

- To program:**
1. Dial **32**. *“AUXILIARY LINES”*
 2. Select line ports to be assigned (LED On = Assigned).
 - Line port 1–14 = Dial **01–14** or Press **A1–A14**.
 - Line port 15, 16 = Dial **15, 16** or press **B1, B2**.
 - Line port 17–24 = Dial **17– 24** or press **HOLD** then press **A1–A8**.
 3. Dial ***** for configuration mode.
- To change setting, repeat procedure and make different selection.

Central Office Lines

Description: You can condition line ports to serve as a ports for standard telephone company supplied central office lines.

- To program:**
1. Dial **33**. *“C.O. LINES”*
 2. Select line ports to be assigned
 - Line port 1–14 = Dial **01–14** or Press **A1–A14**.
 - Line port 15, 16 = Dial **15, 16** or press **B1, B2**.
 - Line port 17–24 = Dial **17– 24** or press **HOLD** then press **A1–A8**.
 3. Dial ***** for configuration mode.
- To change setting, repeat procedure and make different selection.

3.6.7 Line To Line Port Re-Assignment

Description: You can reassign the programming attributes for a line that the installer has connected to a particular line port to a different line port with this programming action. This feature allows you to automatically exchange all software attributes for one line with those assigned to another at a different line port without physically re-locating the lines or reprogramming any of the attributes.

- To Program:**
1. Dial **41**. *“ASSIGN LOGICAL/PHYS ”*
 2. Select currently assigned line port number. *“PHYS LATCH XX”*
 - Line port 1–14 = Dial **01–14** or Press **A1–A14**.
 - Line port 15, 16 = Dial **15, 16** or press **B1, B2**.
 - Line port 17–24 = Dial **17– 24** or press **HOLD** then press **A1–A8**.
 3. Dial new line port number (**01–24** = line 1–24). *“LOGICAL LINE XX”*
 4. Dial **#** to make assignment.
 5. Repeat steps 2–4 for another assignment
—OR—
dial ***** for configuration mode.

To change setting, repeat procedure and make different selection or make same port selections in both steps 2 and 3 to match logical to physical assignment.

3.6.8 Pulse/Tone Switchable

You can configure individual lines to have tone dialing or pulse dialing at default.

Pulse Dialing

Description: If the installer has connected rotary dial lines to the system, you must condition those line ports as pulse dial ports.

NOTE: *The user can switch from pulse dialing (rotary dial signaling) to tone dialing (dual tone multiple frequency—DTMF) for accessing special circuits requiring DTMF tones, such as banking machines, when they need to do so from a rotary dial line.*

- To Program:**
1. Dial **36**. *“PULSE DIAL”*
 2. Select pulse dial line ports (LED On = Pulse):
 - Line port 1– 14 = Dial **01–14** or Press **A1–A14**.
 - Line port 15, 16 = Dial **15, 16** or press **B1, B2**.
 - Line port 17–24 = Dial **17– 24** or press **HOLD** then press **A1–A8**
 - OR—
 - dial **00** to default all lines to pulse dial.
 3. Dial ***** for configuration mode.

To change setting, repeat procedure and make different selection.

Tone Dialing

Description: If the installer has connected tone dial lines to the system, you must condition those line ports as tone dial ports.

- To Program:**
1. Dial **37**. *“TONE DIAL”*
 2. Select pulse dial line ports (LED On = Pulse):
 - Line port 1– 14 = Dial **01–14** or Press **A1–A14**.
 - Line port 15, 16 = Dial **15, 16** or press **B1, B2**.
 - Line port 17–24 = Dial **17– 24** or press **HOLD** then press **A1–A8**
 - OR—
 - dial **00** to default all lines to tone dial.
 3. Dial ***** for configuration mode.

To change setting, repeat procedure and make different selection.

3.6.9 Block Programming

Description: You can use this configuration procedure to assign those features that you have assigned to any one line (using the procedures detailed on the previous pages) to any other line or to an entire block of lines.

To Program: Line Button Method

1. Dial **42**. *“BLK PROGRAMMING”*
2. Select model line port. *“MODEL LINE XX”*
 Line port 1–14 = Press **A1–A14**
 Line port 15, 16 = Press **B1, B2**
 Line port 17–24 = Press HOLD then press **A1–A8**.
3. Select lines to match model line (as detailed above).
4. Dial * and repeat steps 2 and 3 for next model line.
 —OR—
 Dial ** for configuration mode.

Keypad Method

1. Dial **42**. *“BLK PROGRAMMING”*
2. Select model line port *“MODEL LINE XX”*
 Line port 1– 24 = Dial **01–24**.
3. Dial first line port in block (dial **01–24**).
4. Dial #.
5. Dial last line port in block (dial **01–24**).
6. Dial #.
7. Dial * for next model line.
 — OR—
 Dial ** for configuration mode.

NOTE: *The first, last, and all line ports in between will be block programmed like the model line port. To block program an individual line port, select the first line port and last line port to be the same number. For example: 01, 02#, 02# programs line 02 the same as line port 01 is programmed.*

3.6.10 Positive Disconnect Supervision

Description: When a station is on line with an outside caller and the caller hangs up, the CO may send a positive disconnect signal to the DSU II. You can enable the positive disconnect supervision feature on a per-line basis. If you enable positive disconnect supervision, when the system receives the CO's positive disconnect signal the system resets the toll restriction, releases the current call record, and creates a new call record in its place.

- To Program:**
1. Dial **48**. *“DIS. SUPERVISION”*
 2. Select line ports for disconnect supervision (LED On = lines selected to receive tables).
 - Line port 1–14 = Dial **01–04** or press **A1–A14**.
 - Line port 15, 16 = Dial **15, 16** or press **B1, B2**.
 - Line port 17–24 = Dial **17–24** or press **HOLD** then press **A1–A8**.
 3. Dial ***** for configuration mode.

3.7 Station Features

Station programming means that you are programming the functions for one particular station, or port. While it isn't necessary, it is a good idea to do station programming after you have done system and line programming. You should make a record in Chapter 4 of all programming decisions that you make—it will help you keep track of what you have done and will help you troubleshoot any problem that might arise later.

NOTE: *A lighted LED next to the programming button for the selection indicates the current configuration. When a single button provides a toggle (on/off) action, the lighted LED indicates the active feature.*

The first step in any programming sequence is to enter the base level. Once in this mode, you can dial the feature code for any desired configuration. Enter the base level with the following procedure: press **INTERCOM** then dial ***# 7 4 6 ***. The last step is to press the **SPEAKER** button to end the programming procedure and return the system to normal operation.

Make station port selection by dialing a selection number on the keypad or pressing the console button according the following reference table.

Station Port Codes

Station Ports	Keypad Buttons	Console Buttons
10-57	10-57	C10-57

3.7.1 Access Denied

Description: You can deny access to certain lines at certain stations. When you do this, a station user cannot select a denied line.

- To Program:**
1. Dial **54**. *“STA/LINE CONFIG.”*
 2. Dial **5**. *“ACCESS DENY”*
 3. Select line ports (LED On = Access Denied)
 - Line port 1–14 = Dial **01–14** or press **A1–A14**
 - Line port 15, 16 = Dial **15, 16** or press **B1, B2**
 - Line port 17–24 = Dial **17–24** or press **HOLD** then press **A1–A8**.
 4. Dial **#** when all line ports are selected.
 5. Select station ports (LED On = Feature Assigned)
 - Station 10–57 = Dial **10–57** or press **C10–C57**.
 6. Dial ***** when all station ports are selected
 - OR—
 - dial ****** for next station/line feature
 - OR—
 - dial ******* for configuration mode.

To change setting, repeat procedure and make different selection.

To clear current setting, repeat procedure.

3.7.2 All-Call and Zone Paging

You can program the system so that the users can make announcements to stations located in certain areas of the site or to all of the stations. Similarly, you can program a station with one-button access to the paging feature.

Assign All-Call Or Zone Paging Feature

Description: Telephone users can receive voice announcements through their telephone loudspeakers, or through an external paging amplifier and speaker connected to a PA port. They can transmit these voice announcements with their telephone handsets. You can arrange the programming so that the users can make announcements to stations located in certain areas of the site or to all of the stations. By default, All-Call Originate and Receive is available to all stations.

- To Program:**
1. Dial **55**. *“PAGING”*
 2. Choose paging assignment
 - Dial **1** for zone 1 originate *“ORIGINATE ZONE 1”*
 - Dial **2** for zone 2 originate *“ORIGINATE ZONE 2”*
 - Dial **3** for zone 3 originate *“ORIGINATE ZONE 3”*
 - Dial **4** for all-call originate *“ALL-CALL ORIG.”*
 - Dial **5** for zone 1 receive *“RECEIVE ZONE 1”*
 - Dial **6** for zone 2 receive *“RECEIVE ZONE 2”*
 - Dial **7** for zone 3 receive *“RECEIVE ZONE 3”*
 - Dial **8** for all-call receive *“ALL-CALL RECEIVE”*
 - Dial **9** to clear all assignments. *“CLEAR PAGING”*
 3. Select station ports (LED On = Feature Active).
 - Station 10– 57 = Dial **10–57** or press **C10–C57**.
 4. Dial * to assign other paging
 - OR—
 - dial * * for configuration mode.

To change setting, repeat procedure and make different selection.

Assign All-Call and Zone Paging Button

Description: If you wish, you can assign a paging button to provide a station with one-button access to the all-call and zone paging feature.

- To Program:**
1. Dial **56**. *“BUTTON MAPPING ”*
 2. Dial **09**. *“ASSIGN ZONE”*
 3. Select button to be programmed (LED On = Paging Button).
— Press **A1–A14, B1–B8**.
 4. Dial **1–3** for zone 1–3 *“ASSIGN ZONE X ”*
— OR—
dial **4** for all-call. *“ASSIGN ALL CALL ”*
 5. Select station ports (LED On = Button Assigned To Port)
— Station 10–57: Dial **10–57** or press **C10–C57**.
 6. Dial * for further paging button assignment
—OR—
dial * * for next button mapping feature
—OR—
dial * * * for configuration mode.

To clear a paging button, dial **5604**, press paging button, dial #, and repeat steps 5 and 6.

3.7.3 Audible Monitoring

The DSS/BLF at a multiline station provides a visual indication of idle, busy, and ringing status of the monitored stations. You can also provide audible indication of direct and delayed ringing for selected stations; however, you must first enable the station monitoring feature on a system-wide basis.

Enable Audible Monitoring

Description: Enable audible monitoring on a system-wide basis using this feature.

- To Program**
1. Dial **20**. *“MONITOR XXXXXXXX”*
 2. Press **A1** to switch between enable and disable (LED On = Enable)
—OR—
dial **1** to Enable *“MONITOR ENABLED”*
dial **2** to Disable. *“MONITOR DISABLED”*
 3. Dial ***** for configuration mode.
- To change setting, repeat procedure and make opposite selection.

Assign Audible Monitoring To Stations

Description: Once you have enabled audible monitoring system wide, you must select each station and the type of audible monitoring that you want to program.

- To Program:**
1. Dial **53**. *“STATION FEATURES”*
 2. Dial **20**. *“AUDIBLE MONITOR ”*
 3. Select monitoring type.
—Dial **1** for no audible monitoring *“NONE”*
—Dial **2** for direct ring monitoring *“DIRECT RING”*
— Dial **3** for delayed ring monitoring. *“DELAYED RING ”*
 4. Select stations ports (LED On = Feature Assigned)
—Station 10-57: Dial **10-57** or press **C10-C57**.
 5. Dial ***** next monitoring condition
—OR—
dial ****** for next station feature
—OR—
dial ******* for configuration mode.

To change setting, repeat procedure and make different selection.

3.7.4 Automatic Hold

You can give station users the ability to place an existing line or intercom call on hold when she or he presses another line button.

Automatic Hold With Line Calls

Description: When you enable this feature, the telephone user can automatically place an existing line call on hold when she or he presses another line button to answer a second call.

- To Program:**
1. Dial **53**. *“STATION FEATURES”*
 2. Dial **11**. *“AUTO HOLD ”*
 3. Select station ports (LED On = Feature Assigned).
—Station 10-57: Dial **10-57** or press **C10-C57**.
 4. Dial * for next station feature
—OR—
dial * * for configuration mode.

To clear current setting, repeat procedure.

Automatic Hold With Intercom Calls

Description: If you want the telephone user to also have the automatic hold feature while he or she is on an existing intercom call and presses another intercom button or a line button, take this additional programming action.

- To Program:**
1. Dial **53**. *“STATION FEATURES”*
 2. Dial **12**. *“ITCM AUTO HOLD”*
 3. Select station ports (LED On = Feature Assigned)
—Station 10-57: Dial **10-57** or press **C10-C57**.
 4. Dial * for next station feature
—OR—
dial * * for configuration mode.

To clear current setting, repeat procedure.

3.7.5 Automatic Privacy

You can make a line private or non-private. In the private mode, a station has exclusive use of a line during a call. You can arrange for individual stations to automatically release privacy while on private lines.

Make A Line Private Or Non-Private

Description: Use this feature to make a particular line private or non-private.

- To Program:**
1. Dial **40**. *“PRIVACY RELEASE ”*
 2. Select line ports to be non-private (LED On = Non Private Port)
 - Line port 1–14 = Dial **01–14** or Press **A1–A14**
 - Line port 15, 16 = Dial **15, 16** or press **B1, B2**
 - Line port 17–24 = Dial **17–24** or press **HOLD** then press **A1–A8**.
 3. Dial ***** for configuration mode.
- To clear current setting, repeat procedure.

Arrange Station To Automatically Release Privacy On Private Line

Description: You can arrange for individual stations to automatically release privacy while on private lines. With this arrangement, other stations can join the programmed station whenever it is on the line that you have assigned as a privacy release line.

- To Program:**
1. Dial **54**. *“STA/LINE CONFIG.”*
 2. Dial **4**. *“PRIVACY RELEASE”*
 3. Select privacy release line ports (LED On = Selected Ports).
 - Line port 1–14 = Dial **01–14** or press **A1–A14**
 - Line port 15, 16 = Dial **15, 16** or press **B1, B2**
 - Line port 17–24 = Dial **17–24** or press **HOLD** then press **A1–A8**.
 4. Dial **#** when all line ports are selected.
 5. Select station ports (LED On = Feature Assigned)
 - Station 10–57: Dial **10–57** or press **C10–C57**.
 6. Dial ***** when all station ports are selected
 - OR—
 - dial ****** for next station/line feature
 - OR—
 - dial ******* for configuration mode.
- To clear current setting, repeat procedure.

3.7.6 Call Forward On Busy/Ring-No Answer

The system can automatically forward busy and/or ring-no answer (RNA) calls to a new station. The system sends these calls to any idle station associated either by intercom hunt group or by department with the called station. Use this feature to arrange for calls to cycle rapidly through such associated stations by testing each one in turn with several rings.

Call Forwarding Of RNA Calls

Description: Enable call forward of RNA calls for individual stations using this programming feature.

NOTE: *If you enable this feature, also program the system intercom signaling as tone for the first choice.*

- To Program:**
1. Dial **53**. *“STATION FEATURES”*
 2. Dial **21**. *“CALL FWD RNA ”*
 3. Dial **0-9** for 0-9 rings before forwarding. *“RING S= X”*
 4. Select station ports (LED On = Feature Assigned)
—Station 10-57: Dial **10-57** or press **C10-C57**.
 5. Dial * for for additional station ring assignments,
—OR—
dial * * for next station feature,
—OR—
dial * * * for configuration mode.

To remove call forwarding from a station, assign 0 rings.

Call Forwarding Of Busy Calls

Description: Enable call forward of busy calls for individual stations using this programming feature.

- To Program:**
1. Dial **53**. *“STATION FEATURES”*
 2. Dial **41**. *“CALL FWD BUSY”*
 3. Select station ports (LED On = Feature Assigned)
—Station 10-57: Dial **10-57** or press **C10-C57**.
 4. Dial * for next station feature
—OR—
dial * * for configuration mode.

Set Tone First Intercom Signaling

Description: You must set the first choice intercom signaling method to tone first to ensure forwarding of calls that encounter a busy signal or a ring with no answer.

- To Program:**
1. Dial **16**. *“XXXXX ANN. FIRST”*
 2. Press **A1** to toggle from Voice To Tone (LED Off = Tone)
— OR—
dial **2** for Tone First. *“TONE ANN. FIRST”*
 3. Dial ***** for configuration mode.

To change setting, repeat procedure and make opposite selection.

Intercom Hunt Group

Description: You can link stations together to form intercom hunt groups. Calls to a busy station that is in a hunt group will search the group for an idle station to ring.

- To Program:**
1. Dial **53**. *“STATION FEATURES”*
 2. Dial **18**. *“HUNT LINK”*
 3. Select first linking station
— Station 10-57 = Dial **10-57** or press **C10-C57**.
 4. Select second linking station
— Station 10-57 = Dial **10-57** or press **C10-C57**.
 5. Dial ***** for another link
(Example A: 17 to 16, 18 to 16 and 19 to 16)
(Example B: 16 to 17, 17 to 18, and 18 to 16)
—OR—
dial ****** for next station feature
—OR—
dial ******* for configuration mode.

To clear current setting, hunt link station to itself.

3.7.7 Call Origination Denied

Description: You can deny users of selected stations the ability to originate calls on specified lines. This feature does not prevent the user from answering incoming calls on these lines.

- To Program:**
1. Dial **54**. *“STA/LINE CONFIG.”*
 2. Dial **6**. *“ORIGINATION DENY”*
 3. Select line ports (LED On = Selected Ports).
 - Line port 1–14 = Dial **01–14** or press **A1–A14**
 - Line port 15, 16 = Dial **15, 16** or press **B1, B2**
 - Line port 17–24 = Dial **17–24** or press **HOLD** then press **A1–A8**.
 4. Dial **#** when all line ports are selected.
 5. Select station ports (LED On = Feature Assigned)
 - Station 10–57: Dial **10–57** or press **C10–C57**.
 6. Dial ***** when all station ports are selected
 - OR—
 - dial ****** for next station/line feature
 - OR—
 - dial ******* for configuration mode.
- To clear current setting, repeat procedure.

3.7.8 Central Message Desk

Description: Use this feature to designate one station in the system as the central message desk. When you do this, the system automatically arranges for the central message desk station to have message wait originate capability so that it can control message waiting lights at other stations.

- To Program:**
1. Dial **53**. *“STATION FEATURES”*
 2. Dial **08**. *“MSG DESK”*
 3. Select station ports (LED On = Feature Assigned)
 - Station 10–57: Dial **10–57** or press **C10–C57**.
 4. Dial ***** for next station feature
 - OR—
 - dial ****** for configuration mode.
- To clear current setting, repeat procedure.

3.7.9 Data Security Port

Description: While port is active on a call, this feature prevents any incoming tones associated with other system features from interrupting the call.

- To Program:**
1. Dial **53**. *“STATION FEATURES”*
 2. Dial **26**. *“DATA SECURE PORT”*
 3. Select station port (LED On = Feature Assigned)
—Station 10–57: Dial **10-57** or press **C10-C57**.
 4. Dial * for next station feature
—OR—
dial * * for configuration mode.

To clear current setting, repeat procedure.

3.7.10 Dual Console Feature

Description: The dual console feature allow users to have two DSS/BLF consoles to complement one telephone.

- To program:**
1. Dial **53** for station features. *“STATION FEATURES”*
 2. Dial **34** to enable second console. *“SECOND CONSOLE ”*
 3. Select console port
—Station 10–57: Dial **10-57** or press **C10-C57**.
 4. Select station port that console is to complement
—Station 10–57: Dial **10-57** or press **C10-C57**.
 5. Dial * for next station feature
—OR—
dial * * for configuration mode.

To clear second-console assignment, perform the following steps:

- (a) Repeat steps 1 through 3 above
- (b) Type console port number twice
- (c) Dial * * for configuration mode.

3.7.11 Executive Override

Description: You can provide selected stations with busy override. This feature allows the station to override a busy condition at a station, sound a warning tone, and gain access to the existing conversation.

- To Program:**
1. Dial **53**. *“STATION FEATURES”*
 2. Dial **02**. *“EXEC. OVERRIDE ”*
 3. Select station ports (LED On = Feature Assigned)
—Station 10-57: Dial **10-57** or press **C10-C57**.
 4. Dial * for next station feature
—OR—
Dial * * for configuration mode.

To clear current setting, repeat procedure.

3.7.12 Flexible Ringing Assignments

You can enable different ringing assignments for individual lines and stations.

Direct/Delayed Ringing

Description: You must program ringing assignments on a per station/per line basis. You can control ringing for every line that has appearance at a station assigning immediate, or direct, ringing to some lines and delayed ringing to others.

NOTE: *Do not program direct ringing for lines that you assign to the direct department calling feature.*

To Program:	1. Dial 54 .	“ <i>STA/LINE CONFIG.</i> ”
	2. Dial 1	“ <i>DIRECT RING</i> ”
	—OR—	
	Dial 2 .	“ <i>DELAY RING</i> ”

NOTE: *For no station ringing, skip step 3 and make no line selection.*

3. Select line ports for ringing (LED On = Selected Ports).
 - Line port 1–14 = Dial **01–14** or press **A1–A14**
 - Line port 15, 16 = Dial **15, 16** or press **B1, B2**
 - Line port 17–24 = **Dial 17–24** or press **HOLD** then press **A1–A8**.
4. Dial # when all line ports are selected.
5. Select station ports (LED On = Feature Assigned)
 - Station 10–57: Dial **10–57** or press **C10–C57**.
6. Dial * when all station ports are selected
 - OR—
 - dial * * for next station/line ringing assignment
 - OR—
 - dial * * * for configuration mode.

To clear current setting, repeat procedure.

Night Transfer (Of Ringing)—Line/Station Assignments

Description: You or the system attendant can place the system into the night transfer (of ringing) mode of operation. While in this mode of operation, the system will activate special line/station ringing assignments. Use this procedure to program these assignments.

- To Program:**
1. Dial **54**. *“STA/LINE CONFIG”*
 2. Dial **3**. *“NIGHT RING”*
 3. Select line ports for night ringing (LED On = Selected Ports)
 - Line port 1–14 = Dial **01–14** or press **A1–A14**
 - Line port 15, 16 = Dial **15, 16** or press **B1, B2**
 - Line port 17–24 = Dial **17–24** or press **HOLD** then press **A1–A8**.
 4. Dial # when all line ports are selected.
 5. Select station ports (LED On = Feature Assigned)
 - Station 10–57 = Dial **10 - 57** or press **C10–C57**.
 6. Dial * when all station ports are selected
 - OR—
 - dial * * for next station/line feature
 - OR—
 - dial * * * for configuration mode.
- To clear current setting, repeat procedure.

Night Transfer (Of Ringing)—Operation

Description: After you have assigned Night Transfer (Of Ringing) to all desired the stations and lines, you must enable the feature operation with this procedure.

- To Program:**
1. Dial **03**. *“NIGHT XFER XXX ”*
 2. Press **A1** to toggle between enable and disable (LED On = Enabled)
 - OR—
 - dial **1** to Enable (A1 LED on) *“NIGHT XFER ON ”*
 - dial **2** to Disable. *“NIGHT XFER OFF”*
 3. Dial * for configuration mode.

To change setting, repeat procedure and make opposite selection.

Delayed Ringing Times

Description: You assign delayed ringing to stations for specific lines, you can also set the time length of the delay.

- To Program:**
1. Dial **17**. *“SYSTEM FEATURES ”*
 2. Dial **05**. *“DELAY RING XX”*
 3. Select delay time (LED On = Selected Time)
 - Dial **1** or press **A1** = 6 seconds *“DELAY RING 6”*
 - Dial **2** or press **A2** = 12 seconds *“DELAY RING 12”*
 - Dial **3** or press **A3** = 18 seconds *“DELAY RING 18”*
 - Dial **4** or press **A4** = 24 seconds *“DELAY RING 24”*
 - Dial **5** or press **A5** = 30 seconds *“DELAY RING 30”*
 - Dial **6** or press **A8** = 36 seconds *“DELAY RING 36”*
 - Dial **7** or press **A9** = 42 seconds *“DELAY RING 42”*
 - Dial **8** or press **A10** = 48 seconds *“DELAY RING 48”*
 - Dial **9** or press **A11** = 54 seconds *“DELAY RING 54”*
 - Dial **0** or press **A12** = 60 seconds *“DELAY RING 60”*
 4. Dial ****** for configuration mode.
 5. Press **SPEAKER** to end.

To clear current setting, repeat procedure and make different selection.

Allow Ringer Off

Description: With the operating system parameters set to default, the rocker switch volume control on DigiTech and *Impact* and *Impression* multiline telephones sets the ringer volume level between off and a maximum level. You can disable the allow ringer off on a system-wide basis. When you do this, users can set the ringer volume of their telephones between a minimum and a maximum level, but can not completely silence it.

- To Program:**
1. Dial **17**. *“SYSTEM FEATURES ”*
 2. Dial **04**. *“RING OFF XXXXXX”*
 3. Press **A1** to toggle between ringer off allow and not allow.
(LED On = Ringer Off allowed)
—OR—
Dial **1** to allow ringer off. *“RING OFF ENABLE”*
Dial **2** to not allow ringer off. *“RING OFF DISABLE”*
 4. Dial ****** for configuration mode.
 5. Press **SPEAKER** to end.

3.7.13 Flexible Station Numbering

Description: The system supports a flexible station numbering plan for calling individual stations and departments. You can program each station port to respond to the dialing of any available number between 10 and 7999; however, the system will not allow you to assign the same dialing code as both a station extension number and a department access code, nor will the system allow you to assign an extension number or access code conflict such as 15 and 1500.

- To Program:**
1. Dial **52**. "ACCESS CODE"
 2. Dial **1** to assign extension number. "ASSIGN EXT. NUM"
 3. Select station port "EXT. XXXX "
 - Station 10-57 = Dial **10-57** or press **C10-C57**.
 4. Dial new extension number. "EXT. XXXX YYYY "

NOTE: *Extension number can be max. of four digits. If less than four digits, leading zeros must be dialed before number. (Example: For ext. no. 15, dial 0015).*

5. Select next station number and assign extension number
— OR—
dial * for configuration mode.

To change setting, repeat procedure and make a different selection.

3.7.14 Group Call Pickup

Description: If a call rings to any station in a prearranged group, a user at another station in that group can dial a group pickup code and answer the call. Assign the stations to call pickup groups using this procedure.

- To Program:**
1. Dial **53**. "STATION FEATURES"
 2. Dial **16**. "GRP. CALL PICKUP"
 3. Dial 0 for no group
—OR—
dial **1-4** for group 1-4. "GROUP X "
 4. Select station ports (LED On = Feature Assigned)
—Station 10-57 = Dial **10-57** or press **C10-C57**.
 5. Dial * for next group
— OR—
dial * * for next station feature
— OR—
dial * * * for configuration mode.

To remove station from call pickup group, assign it to group 0.

3.7.15 Handset Volume Control On Impact Telephones

Description: *Impact* and *Impression* telephones have 8 handset volume settings at default. You may increase the number of volume settings to 13 on an individual station basis.

- To Program:**
1. Dial **53**. *“STATION FEATURES”*
 2. Dial **38**. *“HANDSET VOLUME”*
 3. Select station ports (LED on = Feature Assigned):
—Station 10–57: Dial **10–57** or press **C10–C57**.
 4. Dial * for next station feature
—OR—
dial * * for configuration mode.

To change setting, repeat procedure and make different selection.

3.7.16 Headset Interface

You can program LCD speakerphones equipped with the optional headset jack to use a headset as well as the handset or speakerphone.

NOTE: *The system delivers subdued off-hook voice announcements (SOHVA) to the headset. Because a headset exhibits a coupling effect between the earpiece and microphone, it may allow the outside party to hear a SOHVA message. You should inform the user of this possibility.*

Headset Operation As A Class Of service

Description: When employing DigiTech speakerphones (models 7700S, rev. H and earlier, and 7016S only), you must use this programming procedure to arrange for a station port to allow headset operation.

- To Program:**
1. Dial **53**. “STATION FEATURES”
 2. Dial **13**. “HEADSET MODE”
 3. Select station ports (LED On = Feature Assigned)
—Station 10-57: Dial **10-57** or press **C10-C57**.
 4. Dial * for next station feature
—OR—
dial * * for configuration mode.

To change setting, repeat procedure and make opposite selection.

Headset Operation As A User Function

Description: To arrange for headset operation at a user's telephone (DigiTech models 7700S, rev. I and later, *Impact* model 8024S, and *Impression* models 20nnn and 21nnn) you must program a headset button at the LCD speakerphone to activate the headset option.

- To Program:**
1. Press **INTERCOM** at the user's telephone.
 2. Dial * * **1**.
 3. Select button to be programmed.
—Press **A1-A14, B1-B10**.
 4. Dial **94**.
 5. Press **SPEAKER** to end.

NOTE: *On Impression telephones (models 20nnn and 21nnn) you must disconnect the handset and plug the headset cord in its place.*

3.7.17 Interactive Buttons

Description: The digital telephone system supports the operation of interactive buttons on all currently produced Comdial proprietary LCD speakerphones. Interactive buttons provide users with quick, easy access to system features and an expanded display that prompts them on feature operation and progress. DigiTech and *Impact* LCD speakerphones provide interactive buttons to the user at all times; however, the DigiTech LCD speakerphones (revision H and earlier) do not provide interactive buttons at default and you must take this programming action to enable them.

- To Program:**
1. Dial **53**. *“STATION FEATURES”*
 2. Dial **17**. *“SOFT KEYS”*
 3. Select station ports (LED on = Feature Assigned):
—Station 10–57: Dial **10–57** or press **C10–C57**.
 4. Dial ***** for next station/line feature.
—OR—
Dial ****** for configuration mode.
 5. Press **SPEAKER** to end.

3.7.18 Idle Line Preference

Description: When you enable idle line preference, a station will automatically connect to any assigned and idle line that you have programmed for this purpose when the user takes the station off hook.

- To Program:**
1. Dial **54**. *“STA/LINE CONFIG.”*
 2. Dial **7**. *“IDLE LINE PREF.”*
 3. Select line ports (LED On = Selected Port)
 - Line port 1–14 = Dial **01–14** or press **A1–A14**
 - Line port 15, 16 = Dial **15, 16** or press **B1, B2**
 - Line port 17–24 = Dial **17–24** or press HOLD then press **A1–A8**.
 4. Dial # when all line ports are selected.
 5. Select station ports (LED On = Feature Assigned)
 - Station 10–57: Dial **10–57** or press **C10–C57**.
 6. Dial * when all station ports are selected
 - OR—
 - dial * * for next station/line feature
 - OR—
 - dial * * * for configuration mode.

To clear current setting, repeat procedure.

3.7.19 Personal Ringing Tones

Description: You can program stations to ring in one of six distinctive tones:

1. 666/571 Hz @ 16 Hz warble
2. 1000/800 Hz @ 16 Hz warble
3. 666/571 Hz @ 23 Hz warble
4. 1000/800 Hz @ 23 Hz warble
5. 500/444 Hz @ 16 Hz warble
6. 500/444 Hz @ 23 Hz warble

- To Program:**
1. Dial **53**. *“STATION FEATURES”*
 2. Dial **14**. *“RINGING TONE”*
 3. Select ringing tone
 - Dial **1** for tone 1 *“RINGING TONE 1”*
 - Dial **2** for tone 2 *“RINGING TONE 2”*
 - Dial **3** for tone 3 *“RINGING TONE 3”*
 - Dial **4** for tone 4 *“RINGING TONE 4”*
 - Dial **5** for tone 5. *“RINGING TONE 5”*
 - Dial **6** for tone 6. *“RINGING TONE 6”*
 4. Select station ports (LED On = Feature Assigned)
 - Station 10-57 = Dial **10-57** or press **C10-C57**.
 5. Dial * for next ringing tone assignment
 - OR—
 - press * * for next station feature
 - OR—
 - Press * * * for configuration mode.

To change setting, repeat procedure and make different selection.

3.7.20 Prime Line, Prime Group, And Prime Intercom

Description: If you assign a group of lines, an intercom line, or one individual line to a particular station for use as its prime line, the station automatically selects it for use when the user takes it off-hook.

- To Program:**
1. Dial **53**. *“STATION FEATURES”*
 2. Dial **15**. *“PRIME LINE ”*
 - 3a. Assign prime line *“PRIME LINE XX”*
 - Line port 1– 14 = Dial **01–14** or press **A1–A14**
 - Line port 15, 16 = Dial **15, 16** or press **B1, B2**
 - Line port 17–24 = Dial **17–24** or press **HOLD** then press **A1–A8**.
 - 3b. Assign prime group, dial **51–54** for groups 1–4. *“PRIME LINE GRP X”*
 - 3c. Assign prime intercom, Dial **50** for intercom line. *“PRIME INTERCOM”*
 4. Select station ports (LED On = Feature Assigned)
 - Station 10–57 = Dial **10–57** or press **C10–C57**.
 5. Dial * for next prime line, group, or intercom assignment
 - OR—
 - press * * for next station feature
 - OR—
 - press * * * for configuration mode.
- To clear current setting, repeat procedure.

3.7.21 Message Wait Originate

Description: Any station that you program with this feature can control the message waiting light at other stations in the system. When a station user observes the message waiting light turn on, he or she can press **INTERCOM** and then **HOLD** to call the station that controlled the light.

- To Program:**
1. Dial **53**. *“STATION FEATURES”*
 2. Dial **06**. *“MSG. WAIT ORIG.”*
 3. Select station ports (LED On = Feature Selected).
 - Station 10–57: Dial **10–57** or press **C10–C57**.
 4. Dial * for next station feature
 - OR—
 - dial * * for configuration mode.
- To clear current setting, repeat procedure.

3.7.22 Ringing Line Preference

Description: When you assign this feature to a station, it will automatically answer a ringing line when its user takes it off-hook.

To Program:

1. Dial **53**. *“STATION FEATURES”*
2. Dial **09**. *“RING LINE PREF.”*
3. Select station ports (LED On = Feature Selected)
—Station 10-57: Dial **10-57** or press **C10-C57**.
4. Dial * for next station feature
—OR—
dial * * for configuration mode.

To clear current setting, repeat procedure.

3.7.23 Subdued Off-Hook Voice Announce (SOHVA) Features

With the subdued off-hook voice announce feature, a user can make an announcement to another station that is busy with a call. The station receiving the SOHVA can hear the message, while the distant party cannot. A station using the speakerphone cannot receive a SOHVA.

SOHVA Disable

Description: The SOHVA feature is standard for every station; however, you can disable it for selected stations with this programming selection.

To Program:

1. Dial **53**. *“STATION FEATURES”*
2. Dial **24**. *“SOHVA”*
3. Select station port (LED On = Feature Assigned)
—Station 10- 57 = Dial **10-57** or press **C10-C57**.
4. Dial * for next station feature
—OR—
dial * * for configuration mode.

To clear current setting, repeat procedure.

SOHVA Groups

Description: Use this procedure to arrange station ports to originate and/or receive SOHVA calls by assigning SOHVA calling groups to them. Also provide selective SOHVA calling to the system by arranging certain station ports together into groups for SOHVA calling between one another while excluding other station ports in the system. The system provides eight different fixed-configuration SOHVA groups.

- To Program:**
1. Dial **53**. *“STATION FEATURES”*
 2. Dial **30**. *“SOHVA GROUP”*
 3. Dial **1-8** for group 1-8. *“SOHVA GROUP X ”*
 4. Select all station ports to receive SOHVA group (LED On = Feature Assigned)
—Station 10-57: Dial **10-57** or press **C10-C57**.
 5. Dial ***** and repeat steps 4 and 5 for additional SOHVA group/station assignments
—OR—
dial ****** for next station feature
—OR—
dial ******* for configuration mode.

To remove station from SOHVA group, assign it to group 0.

Fixed SOHVA Groups

SHOVA Group	Group Configurations							
Group 1	1	2	3	4	5	6	7	8
Receive From	X							
Originate To	X	X	X	X				
Group 2	1	2	3	4	5	6	7	8
Receive From	X	X						
Originate To		X	X	X				
Group 3	1	2	3	4	5	6	7	8
Receive From	X	X	X					
Originate To			X	X				
Group 4	1	2	3	4	5	6	7	8
Receive From	X	X	X					
Originate To								
Group 5	1	2	3	4	5	6	7	8
Receive From					X			
Originate To					X			
Group 6	1	2	3	4	5	6	7	8
Receive From						X		
Originate To						X		
Group 7	1	2	3	4	5	6	7	8
Receive From							X	
Originate To							X	
Group 8	1	2	3	4	5	6	7	8
Receive From								X
Originate To								X

SOHVA Tone Burst Quantities

Description: Use this procedure to set the number of SOHVA tone bursts that sounds at the system stations. You can choose from one to six tone bursts, and the choice that you make here affects all stations that receive SOHVA calls.

- To Program:**
1. Dial **17**. *“SYSTEM FEATURES ”*
 2. Dial **03**. *“SOHVA TONES n ”*
 3. Select the quantity of tone bursts.
—Dial **1–6** or press **A1–A5, A8** (LED On = enabled)
 4. Dial ***** for configuration mode.
 5. Press **SPEAKER** to end.

To change setting, repeat procedure and make a different selection.

3.7.24 Service Observing

You can give selected stations the capability to monitor, in an un-announced manner, an active call at another station.

Assign Service Observing

Description: Select stations to have the service observe feature using this programming.

NOTE: *Since this feature requires the executive override feature to function, the system automatically enables that feature for the station when you enable service observing. You can also arrange selected stations so that they cannot be service observed.*

- To Program:**
1. Dial **53**. "STATION FEATURES"
 2. Dial **10**. "SERVICE OBSERVE "
 3. Select station ports (LED On = Feature Assigned).
—Station 10-57: Dial **10-57** or press **C10-C57**.
 4. Dial * for next station feature
—OR—
dial * * for configuration mode.

To clear current setting, repeat procedure.

Block Service Observing

Description: You can block a user's capability to use service observing.

- To Program:**
1. Dial **53**. "STATION FEATURES"
 2. Dial **29**. "UNOBSERVABLE "
 3. Select station ports (LED On = Feature Assigned)
—Station 10-57 = Dial **10-57** or press **C10-C57**.
 4. Dial * for next station feature
—OR—
dial * * for configuration.

To clear current setting, repeat procedure.

3.7.25 Station Disable

Description: You can disable station ports on a per station basis.

- To Program:**
1. Dial **59**. *“DISABLE STATIONS”*
 2. Select station ports to be disabled (LED On = Disabled)
— Station 10-57: Dial **10-57** or press **C10-C57**.
 3. Dial * for configuration mode.
- To enable station, repeat procedure and make opposite selection.

3.7.26 Station Name

Description: You can assign individual names or category names to stations. These names will then be displayed by LCD speakerphones when they are called by the named stations. Typical names could be TEC SER, MKT 1, J Smith. System attendants also have access to this station naming feature.

- To Program:**
1. Dial **06**. *“STATION NAMES ”*
 2. Select station port (LED On = Selected). *“XXXXXX ”*
—Station 10-57: Dial **10-57** or press **C10-C57**.
 3. Dial # to clear current station name.
 4. Refer to character code table, and compose station name (7 digits maximum).
 5. Dial two-digit codes to form station name. *“XXXXXXXX YYYYYYY”*
 6. Dial * for next station and repeat steps 2-5
—OR—
dial * * for configuration mode.

To change setting, repeat procedure and make different selection.

Character Code Table

Character	Code	Character	Code	Character	Code
A	21	a	24	Space	12
B	22	b	25	-	15
C	23	c	26	;	17
D	31	d	34	/	18
E	32	e	35	“	19
F	33	f	36	.	27
G	41	g	44	,	28
H	42	h	45	:	29
I	43	i	46	1	01
J	51	j	54	2	02
K	52	k	55	3	03
L	53	l	56	4	04
M	61	m	64	5	05
N	62	n	65	6	06
O	63	o	66	7	07
P	71	p	74	8	08
Q	11	q	14	9	09
R	72	r	75	0	00
S	73	s	76		
T	81	t	84		
U	82	u	85		
V	83	v	86		
W	91	w	94		
X	92	x	95		
Y	93	y	96		
Z	13	z	16		

3.7.27 Station To Station Port Reassignment

Description: Use this procedure to reassign the programming attributes for a station connected to a particular station port to a different station port (logical to physical reassignment). This feature allows you to automatically exchange all software attributes for a station (logical assignment) connected at one station port with those attributes assigned to another station at a different station port without physically relocating the stations (physical assignment) or reprogramming any of the attributes.

You can use this programming action to reassign the extension number and all other programmable attributes that you have assigned to one station port to a different port. This feature allows you to make adds, moves, and changes without relocating the station wiring.

NOTE: *Do not confuse this feature with the automatic station relocation feature discussed in the system configuration portion of these programming procedures. Also note that the system will not allow you to reassign the station 10/station port 10 assignment.*

- To Program:**
1. Dial **57** to re-assign station to port. "ASSIGN STA/PORT "
 2. Dial station extension number, **0010-7999**. "PHYS POR T XX"
 3. Dial physical port number **10-57**. "LOGICAL STA XX "
 4. Dial **#** to make assignment.
 5. Dial ***** for configuration mode.

To change setting, repeat procedure and make different selection.

3.7.28 System Alarm Report Stations

You can program the system to report any system alarms to designated stations.

Enable Alarm Reporting

Description: If you arrange the system to report alarms, also use this programming feature to enable stations to display alarm reports after the station user takes appropriate action.

- To Program:**
1. Dial **28**. *“ALARM REPORTS ”*
 2. Press **A1** to toggle between enable and disable (LED On = Enable)
—OR—
dial **1** to enable
dial **2** to disable.
 3. Dial ***** for configuration mode.

To change setting, repeat procedure and make different selection.

Select Alarm Reporting Stations

Description: After you turn on the alarm reporting feature, use this procedure to select the alarm reporting station.

- To Program:**
1. Dial **53**. *“STATION FEATURES”*
 2. Dial **28**. *“ALARM RECEIVE ”*
 3. Select station ports (LED On = Selected)
—Station 10-57: Dial **10-57** or press **C10-C57**.
 4. Dial ***** for next station feature
—OR—
dial ****** for configuration mode.

To clear current setting, repeat procedure.

3.7.29 Voice Announce Blocking

Description: This feature allows a station user to block voice-sigaled intercom calls.

- To Program:**
1. Dial **53**. *“STATION FEATURES”*
 2. Dial **04**. *“VOICE BLOCK”*
 3. Select station ports (LED On = Selected).
—Station 10-57 = Dial **10-57** or press **C10-C57**.
 4. Dial * for next station feature
— OR—
dial * * for configuration mode.
- To clear current setting, repeat procedure.

3.7.30 Block Programming

Description: You can use this station configuration procedure to assign those features that you have assigned to any one station to any other station or to an entire block of stations. Block programming includes any mapped button attributes (see section 3.8, *Button Mapping The Stations*) that you have assigned to the model station port.

- To Program:**
1. Dial **58**. *“BLK PROGRAMMING ”*
 2. Select model station port (LED On = Selected)
— Station 10- 57 = dial **10-57** or press **C10-C57**. *“MODEL STA XX”*
 3. Dial first station port in block (dial code as above).
 4. Dial #.
 5. Dial last station port in block (dial code as above).
 6. Dial #.
 7. Dial * for further block programming
—OR—
dial * * for configuration mode.

NOTE: *The first, last and all station ports in between will be block programmed like the model station port. To block program an individual station port, select the first and last port to be the same number. (For example: 25, 26# 26# programs station 26 exactly as 25 .)*

3.8 **Button Mapping The Stations** (Non-Square System Configuration)

You can assign (map) every programmable button at each digital station to be line-select buttons so that they provide access to outside lines; to be direct station select (DSS) buttons so that they provide quick access to system stations; to be special purpose buttons so that they provide telephone users with one-button access to features; or to be idle buttons so that they provide autodial locations for the station user.

Three idle (unmapped) buttons serve as dynamic line buttons. Dynamic line buttons provide a location for the system to temporarily assign a line appearance to a station that normally does not have that particular line assigned to it. While a line is in appearance there, the user can perform any normal call handling operations that he or she wishes to perform. The lines are identified as follows: B1, B2, and B3 on DigiTech telephones (product codes 7700S, 7714X, and 7114S), B1, B2, and B3 on Impression telephones (product codes 2022S, 2122S, 2122X, and 2101N), or L1, L2, and L3 on *Impact* telephones (product codes 8012S, 8024S, 8112N, 8112S, and 8124S). Refer to section 4.4, *Recording The Station Configurations*, for button illustrations.

When you map a button at a station port, press the corresponding button on the programming station to select the button to be mapped. If you must map buttons at a station port while using a programming telephone that does not provide a full complement of buttons, you can dial a 3-digit code to select a button. The table below lists the 3-digit codes and their corresponding buttons.

Button Codes For Impression, DigiTech, and Impact Telephones

Code	Impression	DigiTech	Impact
120	A1	A1	L01
118	A2	A2	L02
116	A3	A3	L03
114	A4	A4	L04
112	A5	A5	L05
110	A6	A6	L06
108	A7	A7	L07
121	A8	A8	L08
119	A9	A9	L09
117	A10	A10	L10
115	A11	A11	L11
113	A12	A12	L12
111	A13	A13	L13
109	A14	A14	L14
122	A15	B9	L15
123	A16	B10	L16
100	B1	B1	L17
101	B2	B2	L18
102	B3	B3	L19
103	B4	B4	L20
104	B5	B5	L21
105	B6	B6	L22
106		B7	L23
107		B8	L24

3.8.1 Account Code Button

Description: Press the account code button and then dial an account code to record a call into a particular category without interrupting the call.

- To Program:**
1. Dial **56**. *“BUTTON MAPPING”*
 2. Dial **17**. *“ASSIGN ACCT KEY ”*
 3. Select button to be programmed
—Press **A1–A14, B1–B10**.
 4. Select station ports (LED On = Selected)
—Station 10–57 = Dial **10–57** or dial **C10–C57**.
 5. Dial * for further ACCOUNT CODE button assignment
—OR—
dial * * for next button mapping feature
—OR—
dial * * * for next configuration mode.

To clear assignment , dial **5604**, press button, dial # select station, and dial ***.

3.8.2 Automatic Call-Back Button

Description: When a user presses this button after they encounter a busy tone, the system will automatically ring both the called station and the user’s station when the called station becomes idle.

- To Program:**
1. Dial **56**. *“BUTTON MAPPING”*
 2. Dial **10**. *“ASSIGN CALL BACK”*
 3. Select button to be programmed
—Press **A1–A14, B1–B10**.
 4. Select station ports (LED On = Selected)
—Station 10–57: Dial **10–57** or press **C10–C57**.
 5. Dial * for next AUTO CALL-BACK button assignment
—OR—
dial * * for next button mapping feature
—OR—
dial * * * for configuration mode.

To clear assignment , dial **5604**, press button, dial # select station, and dial ***.

3.8.3 Blank Buttons

Description: Blank those buttons that you want to be dynamic line buttons or autodial buttons.

NOTE: *When blanking buttons, be sure a previously assigned button is idle (feature not selected by user) before you blank it.*

- To Program:**
1. Dial **56**. *“BUTTON MAPPING”*
 2. Dial **04**. *“BLANK/AUTODIAL”*
 3. Select all buttons to be programmed
—Press **A1–A14, B1– B10**.
 4. Dial #.
 5. Select station ports (LED On = Selected).
—Station 10–57 = Dial **10–57** or press **C10–C57**.
 6. Dial * for further button blanking
—OR—
dial * * for next button mapping feature
—OR—
dial * * * for configuration mode.

3.8.4 Call Forward Button

Description: This button provides one-button forwarding of all calls to another extension.

- To Program:**
1. Dial **56**. *“BUTTON MAPPING”*
 2. Dial **11**. *“ASSIGN CALL FWD ”*
 3. Select button to be programmed
—Press **A1–A14, B1–B10**.
 4. Select station ports (LED On = Selected).
—Station 10–57 = Dial **10– 57** or press **C10–C57**.
 5. Dial * for next CALL FORWARD button assignment
—OR—
dial * * for next button mapping feature
—OR—
dial * * * for configuration mode.
- To clear assignment , dial **5604**, press button, dial # select station, and dial * * *.

3.8.5 Call Park Orbit Button

Description: The call park orbit button will automatically park an active call in orbit when the user presses it.

- To Program:**
1. Dial **56**. *“BUTTON MAPPING ”*
 2. Dial **12**. *“ASSIGN CALL PK”*
 3. Select button to be programmed
—Press **A1–A14, B1–B10**.
 4. Dial **1–9** for parking orbit 1–9. *“ASSIGN CALL PK X”*
 5. Select station ports (LED On = Selected).
—Station 10–57: Dial **10–57** or press **C10–57**.
 6. Dial * for next CALL PARK ORBIT button assignment
—OR—
dial * * for next button mapping feature
—OR—
dial * * * for configuration mode.

To clear assignment, dial **5604**, press button, dial # select station, and dial ***.

3.8.6 Do Not Disturb (DND) Button

Description: Pressing the DND button prevents other stations from calling the DND station.

- To Program:**
1. Dial **56**. *“BUTTON MAPPING”*
 2. Dial **07**. *“ASSIGN DND CODE”*
 3. Select button to be programmed
—Press **A1–A14, B1–B10**.
 4. Select station ports (LED On = Selected)
—Station 10–57 = Dial **10–57** or press **C10–C57**.
 5. Dial * for further DND button assignment
—OR—
dial * * for next button mapping feature
—OR—
dial * * * for configuration mode.

To clear assignment , dial **5604**, press button, dial # select station, and dial ***.

3.8.7 DSS/BLF Button

Description: DSS buttons provide quick access to system stations and their lights and show the busy status of the monitored stations.

- To Program:**
1. Dial **56**. *“BUTTON MAPPING”*
 2. Dial **03**. *“ASSIGN DSS/BLF”*
 3. Select button to be programmed
—Press **A1–A14, B1–B10**.
 4. Select station port (LED On = Selected).
—Station 10–57 = Dial **10–57** or press **C10–C57**.
 5. Repeat steps 3 and 4 until all ports are assigned.
 6. Dial #.
 7. Select station ports (LED On = Selected)
—Station 10–57 = Dial **10–57** or press **C10–C57**.
 8. Dial * for further DSS/BLF button assignment
—OR—
dial * * for next button mapping feature
—OR—
dial * * * for configuration mode.

To clear assignment , dial **5604**, press button, dial # select station, and dial ***.

3.8.8 Line Button

Description: Line select buttons provide access to outside lines.

- To Program:**
1. Dial **56**. *“BUTTON MAPPING”*
 2. Dial **02**. *“ASSIGN LINE”*
 3. Select button to be programmed:
—Press **A1–A14, B1–B10**.
 4. Select line ports to be assigned.
—Line port **1–14** = Dial **01–14** or Press **A1–A14**
—Line port **15, 16** = Dial **15–16** or Press **B1, B2**
—Line port **17–24** = Dial **17–24** or press **HOLD** then press **A1–A8**.
 5. Repeat steps 3 and 4 until all lines are assigned.
 6. Dial **#** to finish button mapping.
 7. Select station port (LED On = Selected)
—Station 10–57: Dial **10–57** or press **C10–C57**.
 8. Dial ***** for further LINE/BUTTON assignment
—OR—
dial ****** for next button mapping feature
—OR—
dial ******* for configuration mode.
- To clear assignment , dial **5604**, press button, dial **#** select station, and dial *******.

3.8.9 Line Group Button

Description: This button provides one-button access to a line group.

- To Program:**
1. Dial **56**. *“BUTTON MAPPING ”*
 2. Dial **13**. *“ASSIGN LINE GRP”*
 3. Select button to be programmed
—Press **A1–A14, B1–B10**.
 4. Dial **1–4** for line group 1–4. *“ASSIGN LINE GRP X”*
 5. Select station ports (LED On = Selected)
—Station 10–57 = Dial **10–57** or press **C10–C57**.
 6. Dial ***** for next LINE GROUP button assignment
—OR—
dial ****** for next button mapping feature
—OR—
dial ******* for configuration mode.
- To clear assignment, dial **5604**, press button, dial **#** select station, and dial *******.

3.8.10 Line Group Queue Button

Description: A station user can queue for a busy line by pressing a line group queue button.

- To Program:**
1. Dial **56**. *“BUTTON MAPPING ”*
 2. Dial **15**. *“ASSIGN LINE GRP Q”*
 3. Select button to be programmed
—Press **A1–A14, B1–B10**.
 4. Select station ports (LED On = Selected).
—Station 10–57 = Dial **10–57** or press **C10–C57**.
 5. Dial * for next LINE GROUP QUEUE button assignment
—OR—
dial * * for next button mapping feature
—OR—
dial * * * for configuration mode.

To clear assignment, dial **5604**, press button, dial # select station, and dial ***.

3.8.11 Multiple Intercom Button

Description: You can assign a second intercom button to stations that may make many intercom calls.

- To Program:**
1. Dial **56**. *“BUTTON MAPPING ”*
 2. Dial **05**. *“ASSIGN 2ND INTERCOM ”*
 3. Select button to be programmed:
—Press **A1–A14, B1–B10**.
 4. Select station ports (LED On = Selected)
—Station 10–57: Dial **10–57** or press **C10–C57**.
 5. Dial * for further MULTIPLE INTERCOM button assignment
—OR—
dial * * for next button mapping feature
—OR—
dial * * * for configuration mode.

To clear assignment, dial **5604**, press button, dial # select station, and dial ***.

3.8.12 Privacy Button

Description: A user engaged in a private call can press the privacy button to change a current call into a non-private one.

- To Program:**
1. Dial **56**. *“BUTTON MAPPING ”*
 2. Dial **06**. *“ASSIGN PRIVACY ”*
 3. Select button to be programmed
—Press **A1–A14, B1–B10**.
 4. Select station ports (LED On = Selected)
—Station 10–57: Dial **10–57** or press **C10–C57**.
 5. Dial * for further PRIVACY button assignment
—OR—
dial * * for next button mapping feature
—OR—
dial * * * for configuration mode.

To clear assignment , dial **5604**, press button, dial # select station, and dial ***.

3.8.13 Save Button

Description: A telephone user can press the SAVE button to store the last dialed number for later redial.

- To Program:**
1. Dial **56**. *“BUTTON MAPPING”*
 2. Dial **08**. *“ASSIGN SAVE”*
 3. Select button to be programmed
—Press **A1–A14, B1–B10**.
 4. Select station ports (LED On = Selected)
—Station 10–57 = Dial **10–57** or press **C10–C57**.
 5. Dial * for further SAVE button assignment
—OR—
dial * * for next button mapping feature
—OR—
dial * * * for configuration mode.

To clear assignment, dial **5604**, press button, dial # select station, and dial ***.

3.8.14 Voice Announce Block Button

Description: Telephone users can block voice announced intercom calls and station paging by pressing this button.

- To Program:**
1. Dial **56**. *“BUTTON MAPPING ”*
 2. Dial **14**. *“ASSIGN V. A. B.”*
 3. Select button to be programmed
—Press **A1–A14, B1–B10**.
 4. Select station ports (LED On = Selected)
—Station 10–57 = Dial **10–57** or press **C10–C57**.
 5. Dial * for next VOICE ANNOUNCE BLOCK button assignment
—OR—
dial * * for next button mapping feature
—OR—
dial * * * for configuration mode.

To clear assignment , dial **5604**, press button, dial # select station, and dial * * *.

3.8.15 Zone Page/All-Call Button

Description: This button will provide a station with one-button access to all-call and zone paging.

- To Program:**
1. Dial **56**. *“BUTTON MAPPING ”*
 2. Dial **09**. *“ASSIGN ZONE”*
 3. Select button to be programmed
—Press **A1–A14, B1–B10**.
 4. Dial **1–3** for zone 1–3 *“ASSIGN ZONE X”*
— OR—
dial **4** for all-call. *“ASSIGN ALL CALL ”*
 5. Select station ports (LED On = Selected)
Station 10–57 = Dial **10–57** or press **C10–C57**.
 6. Dial * for further paging button assignment
—OR—
dial * * for next button mapping feature
—OR—
dial * * * for configuration mode.

To clear assignment, dial **5604**, press button, dial #, select station, and dial * * *.

3.9 Account Codes

The digital telephone system uses account codes to identify calls by category, or by any other desired grouping, so that it can record the cost of the calls by that category or grouping. The account code can be either verified or not verified by the system; plus, the system can either force the users to use the account codes or make their use of it optional. When you enable account code verification, the system compares the account code entered by a station user with the account entries that you have programmed. If the system does not find a match and the account code entry is optional, the system sounds an error tone through the telephone but does not prevent dialing; however, if forced entry is enabled, the system prevents further dialing until the user enters a matching account code.

You should make a record in Chapter 4 of all programming decisions that you make—it will help you keep track of what you have done and will help you troubleshoot any problem that might arise later.

NOTE: *A lighted LED next to the programming button for the selection indicates the current configuration. When a single button provides a toggle (on/off) action, the lighted LED indicates the active feature.*

The first step in any programming sequence is to enter the base level. Once in this mode, you can dial the feature code for any desired configuration. Enter the base level with the following procedure: press **INTERCOM** then dial ***# 7 4 6 ***. When you want to end the programming, press the **SPEAKER** button to end the programming procedure and return the system to normal operation.

3.9.1 Account Code Length

Length For Verified Account Codes

Description:

This feature defines the number of digits that the system will verify before it accepts the account code as valid. Verified account code length also defines the number of valid account codes that the system will store (as shown in the following table). *Be aware that when you change the verified account code length, the system empties the current list of valid account codes.*

Account Code Lengths

Digits Verified	Number Of Codes
3	1000
4	400
5, 6	266
7, 8	200
9, 10	160
11, 12	133
13, 14	114
15, 16	100

To Program: To specify the number of verifiable account code digits,

1. Dial **75**. “*SMDA PROGRAMMING*”
2. Dial **15**. “*DIGITS VALID X* ”
3. Dial number of digits **3–16** to be verified.
4. Dial *** *** for configuration mode.

To change setting, repeat procedure and make different selection.

Length For Entered Account Codes

Description: This feature defines the number of account code digits that a user must enter before the system will accept the code. Account code length can range from 3 to 16 digits; however, its length must always be equal to or greater than the current verified account code length.

To Program: To specify the number of entered account code digits,

1. Dial **75**. "SMDA PROGRAMMING"
2. Dial **09**. "MAX ACCT CODE X "
3. Dial number of digits (**3—16**) for account code length.

NOTE: *The entered digits must be equal to or greater than the verifiable digits specified in Section 3.9.1 but can not be greater than 16.*

4. Dial * * for configuration mode.

To change setting, repeat procedure and make different selection.

3.9.2 Account Code List

Description: Use this programming feature to create the list of account codes for use.

- To Program:**
1. Dial **75**. "SMDA PROGRAMMING"
 2. Dial **05**. "SET ACCT. CODE "
 3. Dial account code digits. Maximum number of digits must be equal to number of account code digits specified in *Section 3.9.1*.
 4. To enter another account code, dial #, then dial its number.
 5. Dial ** for configuration mode.

To remove account codes from list,

1. Dial **75**. "SMDA PROGRAMMING"
2. Dial **06**. "CLEAR ACCT. CODE"
3. Dial account code to be removed.
4. To remove another account code, dial #, then dial its number.
5. Dial * * for configuration mode.

3.9.3 Enabled or Disabled Account Codes

Description: Use this procedure to enable or disable the account code feature for the system.

- To Program:**
1. Dial **75**. *“SMDA PROGRAMMING”*
 2. Dial **07**. *“XXXXXXXXX ACCOUNT”*
 3. Press **A1** to toggle the feature on or off (LED On = Enabled).
—OR—
Dial **1** to enable account codes. *“ENABLE ACCOUNT”*
Dial **2** to disable account codes. *“DISABLE ACCOUNT”*
 4. Dial * * for configuration mode.

To change setting, repeat procedure and make opposite selection.

3.9.4 Forced or Optional Entry Account Codes

Description: Use this programming procedure to arrange for the system to either force the user’s to enter account codes before they can make calls or to make the enter of account codes an optional condition.

- To Program:**
1. Dial **53**. *“STATION FEATURES”*
 2. Dial **35**. *“FORCE ACCT. CODE”*
 3. Press **A1** for forced account codes on all stations
—OR—
press **A2** for optional account codes on all stations.
 4. Select station ports to be exempted (LED On = Forced, Off = Optional)
—Dial **10-57** or press **C10-C57**.
 5. Dial * * for configuration mode.
 6. To change setting, repeat procedure and make opposite selection.

Forced Account Code Emergency Numbers

Description: Even if you arrange for the system to force account code entries, users can always dial emergency numbers without first entering an account code. Use this programming feature to enter up to 10 emergency numbers. Each number can be a minimum of 1 digit and a maximum of 12 digits.

- To Program:**
1. Dial **75**. *“SMDA PROGRAMMING”*
 2. Dial **16**. *“SET EMER. NUMBER”*
 3. Dial emergency number (up to 12 digits).
 4. To enter another emergency number, dial #, then dial number.
 5. Dial ** for configuration mode.

To clear emergency numbers

1. Dial **53**. *“STATION FEATURES”*
2. Dial **17**. *“CLR EMER. NUMBER”*
3. Dial emergency number to be cleared (up to 12 digits).
4. To clear another number, dial #, then dial number.
5. Dial * * for configuration mode.

3.9.5 Message Display Time For Account Codes

Description: When you enable the account code feature, LCD speakerphones prompt users to enter an account code with a displayed message that the system clears at the end of a programmable display time. Use this procedure to set the length of time for the display within the range of 1 to 20 seconds. (The default setting is 5 seconds.) If account codes are forced, the system drops the line if the user fails to enter a valid account code during the display period. You also can make this prompting message appear in the telephone display when the user answers an incoming call. This prompting feature will remind users to enter account codes for answered calls.

To Program:

1. Dial **75**. *“SMDA PROGRAMMING”*
2. Dial **10**. *“DISPLAY TIME X ”*
3. Dial **1–20** to select new display time (in seconds).
4. Dial *** *** for configuration mode.

To change setting, repeat procedure and make different selection.

Incoming And Outgoing Call Prompt For Account Code Entries

Description: You must enable or disable the account code message display time for both incoming and outgoing calls.

To Program:

1. Dial **75**. *“SMDA PROGRAMMING”*
2. Dial **11** for Incoming Calls *“XXXXXXXX INCOMING”*
 —OR—
 dial **12** for Outgoing Calls. *“XXXXXXXX OUTGOING”*
3. Press **A1** to toggle feature on or off (LED On = Enabled)
 —OR—
 dial **1** to enable *“ENABLE INCOMING”*
 dial **2** to disable. *“DISABLE INCOMING”*
4. dials for configuration mode.

To change setting, repeat procedure and make opposite selection.

3.9.6 Verified Account Code Entry

Description: Use this programming procedure to arrange for the system to either verify or not verify the account codes that users enter.

- To Program:**
1. Dial **75**. *“SMDA PROGRAMMING”*
 2. Dial **08**. *“VERIFICATION XXX*
 3. Press **A1** to toggle the feature on or off (LED On = Verified)
—OR—
dial **1** to enable verification *“VERIFICATION ON ”*
dial **2** to disable verification. *“VERIFICATION OFF”*
 5. Dial * * for configuration mode.
- To change setting, repeat procedure and make opposite selection.

3.10 The Industry-Standard Telephone (IST) Interface

The JM008 Expansion Module

The JM008 expansion module is an optional accessory cabinet that you mount on the DSU II's common equipment cabinet to provide the system with an interface for eight IST devices.

The Analog Terminal Interface

The Analog Terminal Interface device (ATI-D) is a multipurpose *on-premise* accessory. It has dual circuits that allows the connection of two IST devices to the DSU II system.

NOTE: *Connect the first ATI-D port to an even station port. All ATI-D ports must be paired.*

Understanding The Programming Requirements For The IST Interface

The IST provides basic intercom service coupled with the ability to access outside lines. Through programming, the IST acts as either an intercom-only telephone or as a full-featured business telephone. You can program the station port through which the IST is being interfaced either for prime intercom or for prime line automatic and idle line preference. (Default is for prime intercom.) You can also program the station port for distinctive ringing and to match the type of dialing method employed by the IST.

You should make a record in Chapter 4 of all programming decisions that you make—it will help you keep track of what you have done and will help you troubleshoot any problem that might arise later.

NOTE: *A lighted LED next to the programming button for the selection indicates the current configuration. When a single button provides a toggle (on/off) action, the lighted LED indicates the active feature.*

The first step in any programming sequence is to enter the base level. Once in this mode, you can dial the feature code for any desired configuration. Enter the base level by pressing **INTERCOM**, then dialing ***# 7 4 6 ***. Press the **SPEAKER** button to end the programming procedure and return the system to normal operation.

3.10.1 IST Station Port Line Assignment

Description: **When you program the port through which the IST is interfaced for prime intercom**, the affect on the user is different depending upon whether the system is operating as a key system or as a hybrid system

- On key configured systems, proprietary telephone users give the IST access to outside lines for call origination through the use of the call transfer feature. You can assign outside line ringing to the station port for IST call answering purposes by programming the station port for the ringing line preference feature and enable ringing for all desired lines.
- On hybrid configured systems, the system gives the IST access to outside lines through line group access. With line group access, IST users dial the group access code over the intercom line to access an outside line for use. The common equipment then selects one of the grouped idle lines for use in the order from the highest numbered line to the lowest numbered line.

When you program the port through which the IST is interfaced for Prime Line Automatic And Idle Line Preference, program an outside line as a prime line at the station port, or program the station port for idle line preference and then program one of the assigned idle lines as a prime line. With both the prime line automatic and the idle

line preference features, the IST has outside line dial tone when users lift the handset. You can assign outside line ringing to the station port for IST call answering purposes or you can enable the ringing line preference feature for the station port. The intercom line is available to an IST even though you have arranged it to have outside line access. After going off-hook, IST users obtain intercom dial tone by performing a hookflash. To perform a hookflash, they must press and release the hookswitch. This action either drops the outside line (if no digits are dialed after lifting the handset) or places it on hold (if digits were dialed) and provides intercom dial tone.

To Program: To assign a prime intercom or assign a prime line (prime line automatic),

1. Dial **53**. *“STATION FEATURES”*
2. Dial **15**. *“PRIME LINE ”*
- 3a. Assign prime line *“PRIME LINE XX”*
 - Line port 1– 14 = Dial **01–14** or press **A1–A14**
 - Line port 15, 16 = Dial **15, 16** or press **B1, B2**
 - Line port 17–24 = Dial **17–24** or press **HOLD** then press **A1–A8**.
- 3b. Assign prime group, dial **51–54** for groups 1–4. *“PRIME LINE GRP X”*
- 3c. Assign prime intercom, Dial **50** for intercom line. *“PRIME INTERCOM”*
4. Select station ports (LED On = Feature Assigned)
 - Station 10–57 = Dial **10–57** or press **C10–C57**.
5. Dial * for next prime line, group, or intercom assignment
 - OR—
 - press * * for next station feature
 - OR—
 - press * * * for configuration mode.

To enable idle line preference,

1. Dial **54**. *“STA/LINE CONFIG.”*
2. Dial **7**. *“IDLE LINE PREF.”*
3. Select line ports (LED On = Selected Port)
 - Line port 1–14 = Dial **01–14** or press **A1–A14**
 - Line port 15, 16 = Dial **15, 16** or press **B1, B2**
 - Line port 17–24 = Dial **17–24** or press **HOLD** then press **A1–A8**.
4. Dial # when all line ports are selected.
5. Select station ports (LED On = Feature Assigned)
 - Station 10–57: Dial **10–57** or press **C10–C57**.
6. Dial * when all station ports are selected
 - OR—
 - dial * * for next station/line feature
 - OR—
 - dial * * * for configuration mode.

3.10.2 IST Distinctive Ringing

Description: Intercom calls that ring at IST equipment have a different cadence than outside calls. For the JM008 interface, the intercom ring cadence is: 0.5 sec. on, .1 sec. off, 0.5 sec. on, 4 sec. off, and the outside call ring cadence is: 2 sec. on, 4 sec. off. For the ATI-D interface, the intercom ring cadence is: 1 sec. on, .5 sec. off, 1 sec. on, 3.5 sec. off, and the outside call ring cadence is: 2 sec. on, 4 sec. off.
If needed, you can disable this distinctive ringing feature to make the intercom ring cadence the same as that for outside calls.

- To Program:**
1. Dial **53**. *“STATION FEATURES”*
 2. Dial **33**. *“DIST. RING XX ”*
 3. Press **A1** to toggle between enable and disable (LED On = Enable)
—OR—
dial **1** to Enable (A1 LED = Enable) *“DIST. RING ON”*
dial **2** to Disable. *“DIST. RING OFF ”*
 4. Dial ***** for next feature
—OR—
dial ****** for configuration mode.

To change setting, repeat procedure and make opposite selection.

3.10.3 IST Through Dialing

Description: With this programming feature enabled, any DTMF signaling tones that are generated by the IST equipment pass through the JM008 or ATI-D, the common equipment, and any line connection into the switched network. The system automatically enables this feature when you connect the JM008 or ATI-D to the DSU II. Equipment such as the proprietary voice mail systems and the 2500 tone dial telephone require thru dialing; however, you should disable this feature for equipment such as model 500 rotary-dial telephones.

- To Program:**
1. Dial **53**. *“STATION FEATURES”*
 2. Dial **07**. *“ATI THRU DIALING”*
 3. Select station ports (LED On = Selected)
—Station 10-57 = Dial **10-57** or press **C10-C57**.
 4. Dial ***** for next feature
—OR—
dial ****** for configuration mode.

To clear current setting, repeat procedure.

3.11 Direct Department Calling

Direct department calling allows the system to assign lines to one of four different departments. Calls received on department lines and calls that are transferred to a department from within the system search for an idle station in that department.

The system distributes department calls evenly throughout the department stations. It does this by placing newly received calls, transferred calls, and held calls in a queue for servicing, assigning these calls a time stamp to ensure that they are serviced in the order of their arrival, and routing them to the department stations in an orderly manner.

The system allows you to create a maximum of four departments with a maximum of 16 stations and a minimum of 3 stations (plus one overflow station) in each department. Since you can assign a station to more than one department, you can add the attendant station to serve as the overflow station in every department. You can also assign separate access codes (extension numbers) to each department. The users can use these access codes for making intercom calls or doing call transfers to the department.

You must assign lines and stations to a department but you do not need to assign department lines to appear at line buttons on department stations. If a site requires that a particular department line appear at a particular department station, you can assign it; however, you must disable both direct and delayed ringing for that line at that station.

Always program the department stations to have a short RNA time to allow a call to search rapidly through a department for an answer. Further, map a Do Not Disturb (DND) button for each department station so that users can press it to place their stations in an off-duty condition.

Understand, that the departments that you form for use with this direct department calling feature are not the same departments that you form for SMDA reporting.

You should make a record in Chapter 4 of all programming decisions that you make—it will help you keep track of what you have done and will help you troubleshoot any problem that might arise later.

NOTE: *A lighted LED next to the programming button for the selection indicates the current configuration. When a single button provides a toggle (on/off) action, the lighted LED indicates the active feature.*

The first step in any programming sequence is to enter the base level. Once in this mode, you can dial the feature code for any desired configuration. Enter the base level with the following procedure: press **INTERCOM** then dial ***# 7 4 6 ***. When you want to end the programming, press the **SPEAKER** button to end the programming procedure and return the system to normal operation.

3.11.1 Access Codes For Direct Department Calling

Description: You can program department access codes to be any number between 10 and 7999; however, the system will not allow you to assign the same dialing code as both a station extension number and a department access code; nor will the system allow an extension number conflict such as 15 and 1500. Further, with system defaulted extension numbers, the assigned department access codes must start at 0058 or larger.

To Program:

1. Dial **52**. "ACCESS CODE"
2. Dial **2** to assign access codes to departments. "DEPT. CALLING "
3. Dial **1-4** for department 1-4. "DEPT X YYYY "
4. Dial new access code. "DEPT X YYYY ZZZZ"

NOTE: *New code can be maximum of four digits. If less than four digits, leading zeros must be dialed before number. Code cannot conflict with station extension numbers.*

5. Dial next department number and program access code
—OR—
dial * for next access code feature
—OR—
dial ** for configuration mode.

3.11.2 Line Ports For Direct Departmental Calling

Description: You can assign outside lines to one of four different departments if you wish. If you do this, calls received on a line that you have assigned to a department will hunt for any idle station in that department to ring.

To Program:

1. Dial **39**. "DEPT. CALLING "
2. Select department
—Dial **0** for none "NO DEPARTMENT "
—Dial **1** for department 1 "DEPARTMENT 1"
—Dial **2** for department 2 "DEPARTMENT 2"
—Dial **3** for department 3 "DEPARTMENT 3"
—Dial **4** for department 4. "DEPARTMENT 4"
3. Select line ports to be assigned (LED On = Assigned)
—Line port **1-14** = Dial **01-14** or Press **A1-A14**
—Line port **15, 16** = Dial **15, 16** or press **B1, B2**
—Line port **17-24** = Dial **17-24** or press **HOLD** then press **A1-A8**.
4. Dial * for next department
—OR—
dial * * for configuration mode.

3.11.3 Station Ports For Direct Department Calling

Description: You can group stations by department to allow a call to search for an idle station within a department. This search occurs when a busy or RNA is encountered at a called department station. The system allows up to four departments with up to 16 stations and a minimum of 3 stations in each one. You can place one additional station in each department to serve as a termination station. Calls that roll to a termination station will follow a call forward if it is set at that station.

- To Program:**
1. Dial **53**. *“STATION FEATURES”*
 2. Dial **19**. *“DEPT. CALLING ”*
 3. Dial **1-4** for department. 1-4. *“DEPARTMENT X*
 4. Select department stations
—Station 10-57 = Dial **10-57**.
 5. Dial * to program next department.
 6. Dial **5-8** for termination station in department 1-4. *“DEPARTMENT X ”*
 7. Select termination station
—Station 10-57 = Dial **10- 57**.
 8. Dial * to program next department termination station
—OR—
dial * * for next station feature
—OR—
dial * * * for configuration mode.

3.11.4 Unanswered Call Transfer Recall Time For Direct Department Calling

Description: A transferred call that remains unanswered in a department after a programmed length of time will return to the transferring station for answering. Set the department transfer recall time with this programming procedure.

- To Program:**
- | | |
|--|---------------------------|
| 1. Dial 11 . | <i>“TRANSFER RECALL”</i> |
| 2. Dial 2 (department transfer recall). | <i>“DEPT XFR RCL XXX”</i> |
| 3. Choose transfer time. | |
| —Dial 1 or Press A1 | <i>“DEPT XFR RCL 10”</i> |
| —Dial 2 or Press A2 | <i>“DEPT XFR RCL 20”</i> |
| —Dial 3 or Press A3 | <i>“DEPT XFR RCL 25”</i> |
| —Dial 4 or Press A4 | <i>“DEPT XFR RCL 30”</i> |
| —Dial 5 or Press A5 | <i>“DEPT XFR RCL 45”</i> |
| —Dial 6 or Press A8 | <i>“DEPT XFR RCL 60”</i> |
| —Dial 7 or Press A9 | <i>“DEPT XFR RCL 90”</i> |
| —Dial 8 or Press A10 | <i>“DEPT XFR RCL 120”</i> |
| —Dial 9 or Press A11 | <i>“DEPT XFR RCL 180”</i> |
| —Dial 0 or Press A12 . | <i>“DEPT XFR RCL 400”</i> |
| 4. Press * for next transfer recall feature. | |
| 5. Press * * for configuration mode. | |

To change setting, repeat procedure and make different selection.

3.11.5 Call Forward on Ring—No Answer

The system can automatically forward ring-no answer calls to a new station. The system sends these calls to any idle station associated by department with the called station. Use this feature to arrange for calls to cycle rapidly through such associated stations by testing each one in turn with several rings.

Call Forwarding Of RNA Calls

Description: Enable call forward of RNA calls for individual stations using this programming feature.

NOTE: *If you enable this feature, also program the system intercom signaling as tone for the first choice.*

- To Program:**
1. Dial **53**. *“STATION FEATURES”*
 2. Dial **21**. *“CALL FWD RNA ”*
 3. Dial **0-9** for 0-9 rings before forwarding. *“RING S= X”*
 4. Select station ports (LED On = Feature Assigned)
—Station 10-57: Dial **10-57** or press **C10-C57**.
 5. Dial * for for additional station ring assignments,
—OR—
dial * * for next station feature,
—OR—
dial * * * for configuration mode.

To remove call forwarding from a station, assign 0 rings.

Set Tone First Intercom Signaling

Description: You must set the first choice intercom signaling method to tone first to ensure forwarding of calls that encounter a busy signal or ring with no answer.

- To Program:**
1. Dial **16**. *“XXXXX ANN. FIRST”*
 2. Press **A1** to toggle from Voice To Tone (LED Off = Tone)
—OR—
dial **2** for Tone First. *“TONE ANN. FIRST”*
 3. Dial * for configuration mode.

To change setting, repeat procedure and make opposite selection.

3.12 Direct Inward Station Dialing (DISD)

The DISD feature allows an external party to call an intercom station directly without assistance by the attendant. The system must receive the DISD call on a line that you have programmed to allow this feature. You can program any line to be a DISD line for both the normal mode of operation and the night transfer (of ringing) mode of operation.

You can program the number of rings that the system allows on a DISD line. If you set a large number of rings, stations that have a line appearance for the DISD line have time to handle the call in a regular manner before the system takes control of the call. If you wish to dedicate a line for DISD use, it is a good practice to set it for one ring so that the system can quickly take control of the call. By setting the number of rings to 0, you can disable the line for DISD use.

You can program the amount of time the system allows for a DISD caller to dial an extension number. You can also program the DISD assist station that will answer calls not completed during the dial time limit.

It is a good practice for you to connect a music source to the system to let callers know they have not been disconnected during a camp-on situation when the DISD feature is controlling the call.

You should make a record in Chapter 4 of all programming decisions that you make—it will help you keep track of what you have done and will help you troubleshoot any problem that might arise later.

NOTE: *A lighted LED next to the programming button for the selection indicates the current configuration. When a single button provides a toggle (on/off) action, the lighted LED indicates the active feature.*

The first step in any programming sequence is to enter the base level. Once in this mode, you can dial the feature code for any desired configuration. Enter the base level with the following procedure: press **INTERCOM** then dial ***# 7 4 6 ***. When you want to end the programming, press the **SPEAKER** button to end the programming procedure and return the system to normal operation.

3.12.1 Dial Time Limit

Description: When a caller does not complete extension number dialing within the programmed dial time limit, the system routes a DISD call to the assist station if you have programmed one; otherwise, it drops the line.

- To Program:**
1. Dial **44**. *“DISD DIALTIME X ”*
 2. Press program button to select dial time limit: (LED On = Enabled)
 - Dial **1** or press **A1** = 6 seconds *“DISD DIALTIME 6”*
 - Dial **2** or press **A2** = 9 seconds *“DISD DIALTIME 9”*
 - Dial **3** or press **A3** = 12 seconds *“DISD DIALTIME 12”*
 - Dial **4** or press **A4** = 15 seconds *“DISD DIALTIME 15”*
 - Dial **5** or press **A5** = 20 seconds *“DISD DIALTIME 20”*
 - Dial **6** or press **A8** = 30 seconds *“DISD DIALTIME 30”*
 - Dial **7** or press **A9** = 40 seconds *“DISD DIALTIME 40”*
 - Dial **8** or press **A10** = 60 seconds *“DISD DIALTIME 60”*
 - Dial **9** or press **A11** = 90 seconds *“DISD DIALTIME 90”*
 - Dial **0** or press **A12** = 0 seconds. *“DISD DIALTIME 0”*
 3. Press ***** for configuration mode.

To change setting, repeat procedure and make different selection.

3.12.2 Inhibiting DISD Digit Dialing

Description: You can prevent callers from dialing on the DISD line when the system is in the night transfer (of ringing) mode of operation.

- To Program:**
1. Dial **17**. *“SYSTEM FEATURES”*
 2. Dial **09**. *“DISD DIALING XX”*
 3. Press **A1** to toggle between enable and disable (LED On = Enable).
—OR—
Dial **1** to Enable (A1 LED is on) *“DISD DIALING ON”*
Dial **2** to Disable. *“DISD DIALING OFF”*
 4. Press ****** for configuration mode.

To change setting, repeat procedure and make different selection.

3.12.3 DISD Assist Station

Description: When a caller does not complete extension number dialing within the programmed dial time limit, the system routes the call to the DISD assist station.

- To Program:**
1. Dial **46**. *“DISD ASSIST”*
 2. Choose operating mode to be programmed
—Dial **1** or press **A1** = normal mode *“DISD ASSIST DAY X ”*
—Dial **2** or press **A2** = night transfer (of ringing) mode. *“DISD ASSIST NITE”*
 3. Select assist station.
—Dial **00** for no DISD assist station (line drops after timeout)
—Dial **10-57** or press **C10-C57** (LED On = Selected).
 4. Dial # .
 5. Assign line ports to DISD assist station (LED On = Assigned)
—Line port 1-14 = Dial **01-14** or Press **A1-A14**
—Line port 15, 16 = Dial **15, 16** or Press **B1, B2**
—Line port 17-24 = Dial **17-24** or press **HOLD** then press **A1-A8**.
 6. Press ***** and repeat steps 2 and 3 for further assist station programming
—OR—
press ****** for configuration mode.

To change setting, repeat procedure and make different selection.

3.12.4 DISD Incoming Rings

Description: The number of rings that occur on a DISD line before it is answered is programmable. Setting a large number of rings allows time for a call to be serviced in a regular manner by stations that have line appearance for the DISD line if such action is desired.

- To Program:**
1. Dial **45**. *“DISD RINGS”*
 2. Press program button to choose operating mode
 - Dial **1** or press **A1** = normal mode *“DISD RINGS DAY X”*
 - Dial **2** or press **A2** = night transfer (of ringing) mode. *“DISD RINGS NITE X”*
 3. Select rings to occur before line is answered
 - Dial **0** for no rings (disables DISD for the line)
 - Dial **1-9** = rings 1-9.
 4. Dial #.
 5. Assign line ports to have designated ring (LED On = Assigned)
 - Line port 1-14 = Dial **01-14** or Press **A1-A14**
 - Line port 15, 16 = Dial **15, 16** or Press **B1, B2**
 - Line port 17-24 = Dial **17-24** or press **HOLD** then press **A1-A8**.
 6. Press * and repeat steps 2 and 3 for further DISD ring assignment
 - OR—
 - press * * for configuration mode.

To change setting, repeat procedure and make different selection.

3.12.5 Enable/Disable Call Waiting Tone

Description: The call waiting tone sent to the called party can be enabled or disabled.

- To Program:**
1. Dial **17** for system features. *“SYSTEM FEATURES”*
 2. Dial **11** for DISD call waiting tone. *“DISD CALL WAIT”*
 3. Press **A1** to toggle between enable and disable
 - OR—
 - Dial **1** to enable call waiting tones.
 - Dial **2** to disable call waiting tones.
 6. Press * for further system features
 - OR—
 - press ** for configuration mode.

3.13 Data Printer Service

When you connect a data printer to the system, the system automatically prints the station message detail record (SMDR) for the entire system without any programming or user intervention.

You can also command the data printer to print partial or complete printouts of the configuration data for the system. While you are using the printer to print the configuration data or SMDA information, the system temporarily halts the SMDR printout although it continues to collect the SMDR data. You should note, however, that if it logs more than two calls for any one line, call records may be lost.

NOTE: *A lighted LED next to the programming button for the selection indicates the current configuration. When a single button provides a toggle (on/off) action, the lighted LED indicates the active feature.*

The first step in any programming sequence is to enter the base level. Once in this mode, you can dial the feature code for any desired configuration. Enter the base level with the following procedure: press **INTERCOM** then dial ***# 7 4 6 ***. When you want to end the programming, press the **SPEAKER** button to end the programming procedure and return the system to normal operation.

3.13.1 Enable Data Printer Operation

- | | | |
|--------------------|---|-------------------------|
| To Program: | 1. Dial 91 . | <i>“PRINT CONFIG.”</i> |
| | 2. Choose configuration | |
| | —Dial 1 to print all configuration data | <i>“PRINT ALL”</i> |
| | —Dial 2 to print system data | <i>“PRINT SYSTEM ”</i> |
| | —Dial 3 to print line data | <i>“PRINT LINES”</i> |
| | —Dial 4 to print data for all stations | <i>“PRINT STATIONS”</i> |
| | —Dial 5 to print data for selected station | <i>“PRINT STA.”</i> |
| | —Select station to be printed | |
| | —Dial 10–57 for stations 10–57 | <i>“PRINT STA. XXX”</i> |
| | —Dial 6 to print toll restriction assignment | <i>“PRINT TOLL”</i> |
| | —Dial 7 to abort printing. | <i>“ABORT PRINT”</i> |
| | 3. Dial * for configuration mode. | |

3.14 Voice Mail Interface

The digital telephone system supports the use of a voice mail system connected to the common equipment's station ports through the JM008 expansion module or the ATI-D analog terminal interface device. The JM008 is an industry-standard telephone station module that supplies eight IST ports. The ATI-D is a multipurpose *on-premise* accessory that has dual circuits to allow a 2-port system to interface to two digital station ports. Two ATI-D devices are needed to interface 4-port systems.

In addition to the required programming task of identifying the station ports as voice mail ports, there are several other programming considerations associated with voice mail operation that are optional for use as needed.

You should make a record in Chapter 4 of all programming decisions that you make—it will help you keep track of what you have done and will help you troubleshoot any problem that might arise later.

NOTE: *A lighted LED next to the programming button for the selection indicates the current configuration. When a single button provides a toggle (on/off) action, the lighted LED indicates the active feature.*

The first step in any programming sequence is to enter the base level. Once in this mode, you can dial the feature code for any desired configuration. Enter the base level with the following procedure: press **INTERCOM** then dial ***# 7 4 6 ***. When you want to end the programming, press the **SPEAKER** button to end the programming procedure and return the system to normal operation.

NOTE: *Some features only apply to specific Comdial voice mail systems (that is, ExecuMail or V.V.P.). If you are using a different voicemail system, you may have to perform additional programming steps to make these features operational.*

3.14.1 Voice Mail Port

Assign The Voice Mail Port

Description: When you connect the voice mail equipment to a common equipment station port either through an IST interface or directly to the port (depending upon the type of voice mail equipment you are using), you must use this *assign voice mail port* feature to enable the station port as a voice mail port. This feature only applies to voice mail systems supported by Comdial's proprietary DTMF integration. Once you perform this step, the station port will only emit DTMF tones (it will not emit INTERCOM tones or ring-back tones).

NOTE: *When you are interfacing voice mail equipment through an ATI-D device and you later replace the ATI-D with a proprietary digital multiline telephone, the system automatically disables the port as a voice mail port; however, if you disconnect the voice mail equipment from the ATI-D and replace it with a model 2500 telephone, you must reprogram the station port so that it is no longer programmed as a voice mail port.*

- To Program:**
1. Dial **53**. "STATION FEATURES"
 2. Dial **32**. "VOICE MAIL PORT "
 3. Select station ports to be programmed (LED On = Selected)
—Station 10-57 = Dial **10-57** or press **C10-C57**.
 4. Dial * for next feature
—OR—
dial * * for configuration mode.

Assign Ringing For Automatic Attendant Operation

Description: With its automatic attendant feature, the voice mail system automatically answers any line that is ringing at a voice mail port. As a default, the system automatically enables ringing line preference for any port that you have identified as a voice mail port. You must choose a ringing assignment for the lines that you have assigned to the voice mail ports before the voice mail system can provide the automatic attendant feature.

- To Program:**
1. Dial **54**. *“STA/LINE CONFIG”*
 2. Dial **1** for direct ringing *“DIRECT RING”*
 —OR—
 dial **2** for delayed ringing *“DELAY RING”*
 —OR—
 dial **3** for night transfer (of ringing). *“NIGHT RING”*
 3. Select line ports for direct ringing
 —Line port 1–14 = Dial **01–14** or press **A1–A14**
 —Line port 15, 16 = Dial **15, 16** or press **B1, B2**
 —Line port 17–24 = Dial **17–24** or press **HOLD** then press **A1–A8**.
 4. Dial **#** when all line ports are selected.
 5. Select voice mail ports to be programmed (LED On = Selected)
 —Station 12–57 = dial **12–57** or press **C12–C57**.
 6. Dial ***** when all station ports are selected.
 7. Dial *** * *** for configuration mode.
- To change setting, repeat procedure and make different selection.
 To clear current setting, repeat procedure.

Assign The Voice Mail Stations To Hunt Group

Description: You must assign all voice mail ports to a circular hunt group to take advantage of that feature’s multiple-port interface capability. Make a circular hunt group by linking all voice mail ports to one another and then linking the last voice mail port in the hunt group with the first voice mail port in the hunt group. For example, with the voice mail system properly connected to station ports 014, 015, 016, and 017, place port 014 in a hunt group and link 015 to it, then place 015 in a hunt group and link 016 to it, then place 016 in a hunt group and link 017 to it, and finally place 017 in a hunt group and link 014 to it to complete the circle. With this arrangement, a call will first try to ring at port 014, then try port 015 and so forth until it tries all four voice mail ports.

To make this hunt group completely functional, you must also assign call forwarding for both ring no-answer and busy calls to the voice mail ports.

To assign voice mail ports to a hunt group,

1. Dial **53**. *“STATION FEATURES”*
2. Dial **18**. *“HUNT LINK”*
3. Select first voice mail port
—Station 12-57 = Dial **12-57** or press **C12-C57**.
4. Select second voice mail port
—Station 12-57 = Dial **12-57** or press **C12-C57**.
5. Dial * for another link
(Example: 16 to 17, 17 to 18, and 18 to 16)
—OR—
dial ** for next station feature
—OR—
dial *** for configuration mode.

Disable link by repeating procedure and linking station to itself.

To enable call forward of RNA calls and busy calls and to set tone first intercom signalling,

1. Dial **53**. *“STATION FEATURES”*
2. Dial **21**. *“CALL FWD RNA ”*
3. Dial **0-9** for 0-9 rings before forwarding. *“RING S= X”*
(To remove call forwarding from a station, assign 0 rings),
4. Select station ports (LED On = Feature Assigned)
—Station 12-57: Dial **12-57** or press **C12-C57**.
5. Dial ** for station feature.
6. Dial **41**. *“CALL FWD BUSY”*
7. Select station ports (LED On = Feature Assigned)
—Station 12-57: Dial **12-57** or press **C12-C57**.
8. Dial ** for configuration mode.

3.14.2 Automatic Transfer of Voice Mail

Description: Use this programming feature to arrange for an immediate connection of a transferred line from voice mail to a digital station port.

- To Program:**
1. Dial **25**. *“V MAIL AUTO XFER”*
 2. Press **A1** to toggle between enable and disable (LED On = Enable)
—OR—
dial **1** to enable (A1 LED is on)
dial **2** to disable.
 3. Dial ***** for configuration mode.

To change setting, repeat procedure and make different selection.

NOTE: *Do not turn on this feature if you turn on the screen and/or confirm options provided by the voice mail system. These two options provide an immediate transfer that will prevent the voice mail system from providing any screen or confirm action.*

3.14.3 Voice Mail Line ID

Description: You can assign voice mail identification (ID) numbers to the voice mail lines. A voice mail ID number can contain a maximum of six digits. A voice mail ID number allows the voice mail equipment to identify which line it is answering and play the appropriate greeting. The ID numbers that you assign here must match the ID numbers that you assign when you program the voice mail equipment.

- To Program:**
1. Dial **43**. *“VOICE MAIL LN ID”*
 2. Select line port (LED On = Line assigned)
—Line port 1-14 = Dial **01-14** or press **A1-A14**
—Line port 15, 16 = Dial **15, 16** or press **B1, B2**
—Line port 17-24 = Dial **17-24** or press **HOLD** then press **A1-A8**.
 3. Dial **#** to clear current ID.
 4. Dial ID number (6 digit maximum).
 5. Dial ***** for further ID assignment
—OR—
dial ****** for configuration mode.

3.14.4 Voice Mail Transfer on Busy

Description: Normally, the auto-attendant routes calls from a busy station to that station's voice mail box. Alternately, you can arrange for the system to alert the busy station when the voice mail system is attempting to transfer a call. You may need to program the attendant station to have this option.

- To Program:**
1. Dial **53**. *"STATION FEATURES"*
 2. Dial **31**. *"VMAIL XFR ON BSY"*
 3. Select station ports to be programmed (LED On = Selected).
—Station ports 10–57: Dial **10–57** or press **C10–C57**
 4. Dial ***** for next feature
—OR—
dial ****** for configuration mode.

To clear current setting, repeat procedure.

3.14.5 Transferring Callers To Voice Mail

Description: You can program a "Transfer To Voice Mail" button to automate the process of transferring a caller to a mail box. Use this button in conjunction with a DSS or a mail box extension number followed by a "2."

- To Program:**
1. Press **INTERCOM ** 1**.
 2. Press the button to which you wish to assign this feature.
 3. Press **6** followed by the first voice mail port station number.
 4. Press **SPEAKER** to exit.

3.14.6 Positive Disconnect Supervision

Description: When a voice mail station is on line with an outside caller and the caller hangs up, the CO may send a positive disconnect signal to the DSU II. You can enable the positive disconnect supervision feature on a per-line basis. If you enable positive disconnect supervision, when the system receives the CO's positive disconnect signal the system tells the voice mail equipment to hang up.

- To Program:**
1. Dial **48**. *"DIS. SUPERVISION"*
 2. Select line ports for disconnect supervision (LED On = lines selected to receive tables).
 - Line port 1–14 = Dial **01–04** or press **A1–A14**.
 - Line port 15, 16 = Dial **15, 16** or press **B1, B2**.
 - Line port 17–24 = Dial **17–24** or press **HOLD** then press **A1–A8**.
 3. Dial * for configuration mode.

3.14.7 Voice Mail Pause

Description: Some voice mail systems allow you to program a pause before they dial an extension number. You can program the digital telephone system to pause before receiving digits from a voice mail system. This capability allows the digital telephone system to match the voice mail system's pause. If the voice mail system does not pause before dialing an extension number, you must disable the fixed one second pause in the digital telephone system.

- To Program:**
1. Press **ITCM *#746***. *"CONFIG. MODE"*
 2. Dial **17**. *"SYSTEM FEATURES"*
 3. Dial **13**. *"VM PAUSE XXX"*
 4. Press **A1** to toggle between VM pause on and VM pause off (LED on = pause on).
 5. Dial **1** for VM pause on. *"VM PAUSE ON"*
 6. Dial **2** for VM pause off. *"VM PAUSE OFF"*
 7. Press * for further system features.
 8. Press * * for configuration mode.

3.15 Versatile Voice Processing

The digital telephone system supports the Versatile Voice Processing (V.V.P.) voice mail system. In addition to the programming requirements detailed in Section 3.14, the following sections detail specific procedures for programming the system to support the V.V.P. voice processing system.

3.15.1 Using The Tracker Paging System With Versatile Voice Processing

Description: The Tracker is available for use with the DSU II digital telephone system. To make effective use of a Tracker paging system used in conjunction with the V.V.P. voice mail system, program two mail boxes for each person using a Tracker. The second mail box will be used to park the caller and track the called person. When a caller selects to *Press 3 for other options*, V.V.P. will place the call in a Park Orbit while paging the called party.

NOTE: *If the V.V.P. system includes the Visual Voice Mail option (Section 3.15.5), you can not use Tracker and VVM at the same time since they both use the COM 1 serial data port.*

Standard Mail Box

- To Program:**
1. Leave the Pager Number field blank.
 2. Set the Pager Type to Name
 3. In the *If caller chooses other options* field, select *Go to box*.
 4. In the Box field enter a box number that is defined as a paging box.

Paging Mail Box

- To Program:** Set the following parameters for the paging mail box.
1. Define this box number so that the system can link it to the person's regular mail box but do not choose a number that is another extension or mail box. For example, precede the mail box number with a **7** for all pager boxes.
 2. Select *Blind Transfer Type*.
 3. Enter ***01** plus the actual mail box number for *Transfer To*,
 4. Record a name for this box such as, *Tracker for Joe Smith* or *Paging Joe Smith*.

3.15.2 Using Tracker For Message Notification

Description: You can program the Tracker to notify mail box users when they have new messages.

To Program: In the *Message Delivery* field for all mail box owners with a Tracker, enter the following code: **,*01,X**

3.15.3 Transferring Callers To Voice Mail

Description: You can program a *Transfer To Voice Mail* button to automate the process of transferring a caller to a mail box. Use this button in conjunction with a DSS or a mail box extension number followed by a **2**.

To Program:

1. Press **INTERCOM ** 1**.
2. Press the button to which you wish to assign this feature.
3. Press **6** followed by the first voice mail port station number.
4. Press **SPEAKER** to exit.

3.15.4 Auto Station Logon

Description: You can program a button to automatically connect a mail box owner to his or her mail box.

To Program:

1. Press **INTERCOM ** 1**.
2. Press the button to which you wish to assign this feature.
3. Press **INTERCOM**.
4. Press **#**.
5. Enter the mail box number.
6. Press **SPEAKER** to exit.

The Auto Station Logon button will take the mail box owner to the mail box password prompt. The following entries must be added to the TRANS.TXT file for this feature to work properly:

```
9#XX=#,,,,,XX
#XX=#,,,,,XX
```

3.15.5 Visual Voice Mail Support

Description: Visual Voice mail (VVM) support provides proprietary, two-line display LCD speakerphone stations with visual messages and interactive buttons. This message and button functionality enhances the station's use with V.V.P. voice mail equipment.

NOTE: *If the V.V.P. system includes the Visual Voice Mail option, you can not use Tracker and VVM at the same time since they both use the COM 1 serial data port.*

- To Program:**
1. Dial **17**. "SYSTEM FEATURES"
 2. Dial **12**. "VMM XXXXXXXX"
 3. Dial code to enable or disable:
 - Dial **1** to enable. "VMM ENABLED"
 - Dial **2** to disable. "VMM DISABLED"
 - OR—
 4. Press **A1** to toggle between enable and disable.
 5. Press ***** for system features.
 6. Press ****** for configuration mode.

3.16 Integrated Call Costing

Call costing provides a means of establishing costing that the system can apply to outside calls made from system telephones. Call costing computes charges for a call after it is completed. It does not restrict dialing as toll restriction does. The system provides several ways of establishing call costing that are as follows:

- exception tables for local and long distance calls,
- office code band tables for local calls,
- zone call band tables for long distance calls,
- area code band tables for long distance calls,
- call rate tables for local and long distance calls.

With this range of costing methods, it is possible to apply reasonable rates for the entire country. The system applies call costing to a dialed number as described below. Refer to *Section 3.16.1* for an illustration of the call costing process.

You should make a record in Chapter 4 of all programming decisions that you make—it will help you keep track of what you have done and will help you troubleshoot any problem that might arise later.

NOTE: *A lighted LED next to the programming button for the selection indicates the current configuration. When a single button provides a toggle (on/off) action, the lighted LED indicates the active feature.*

The first step in any programming sequence is to enter the base level. Once in this mode, you can dial the feature code for any desired configuration. Enter the base level with the following procedure: press **INTERCOM** then dial ***# 7 4 6 ***. When you want to end the programming, press the **SPEAKER** button to end the programming procedure and return the system to normal operation.

3.16.1 Call Costing Flow Diagram Examples

Call Costing Flow Diagram

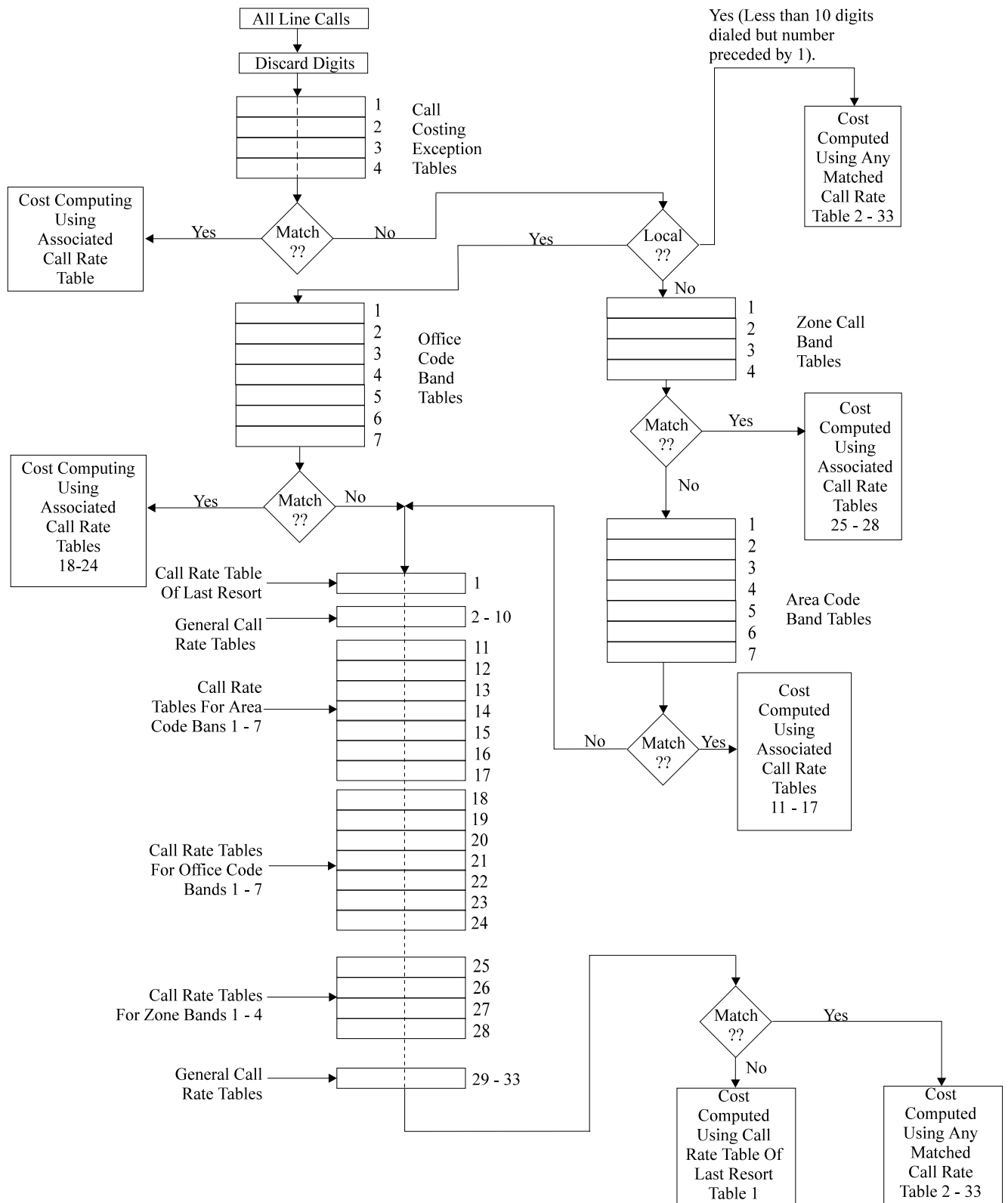

CHART

Example A For Local Dialing Sequence (201-nnnn)

For this example, assume that you have installed the digital telephone system in a location where callers have an opportunity to dial number combinations that contain a common sequence in both the area and office code.

The illustrated sequence is a local call (less than 10 digits) and 201 is the office code. Program call rate 18 to cost calls of this sequence. Also program the office code band table by assigning office code 201 into band one. Note that the band tables accept unlimited entries.

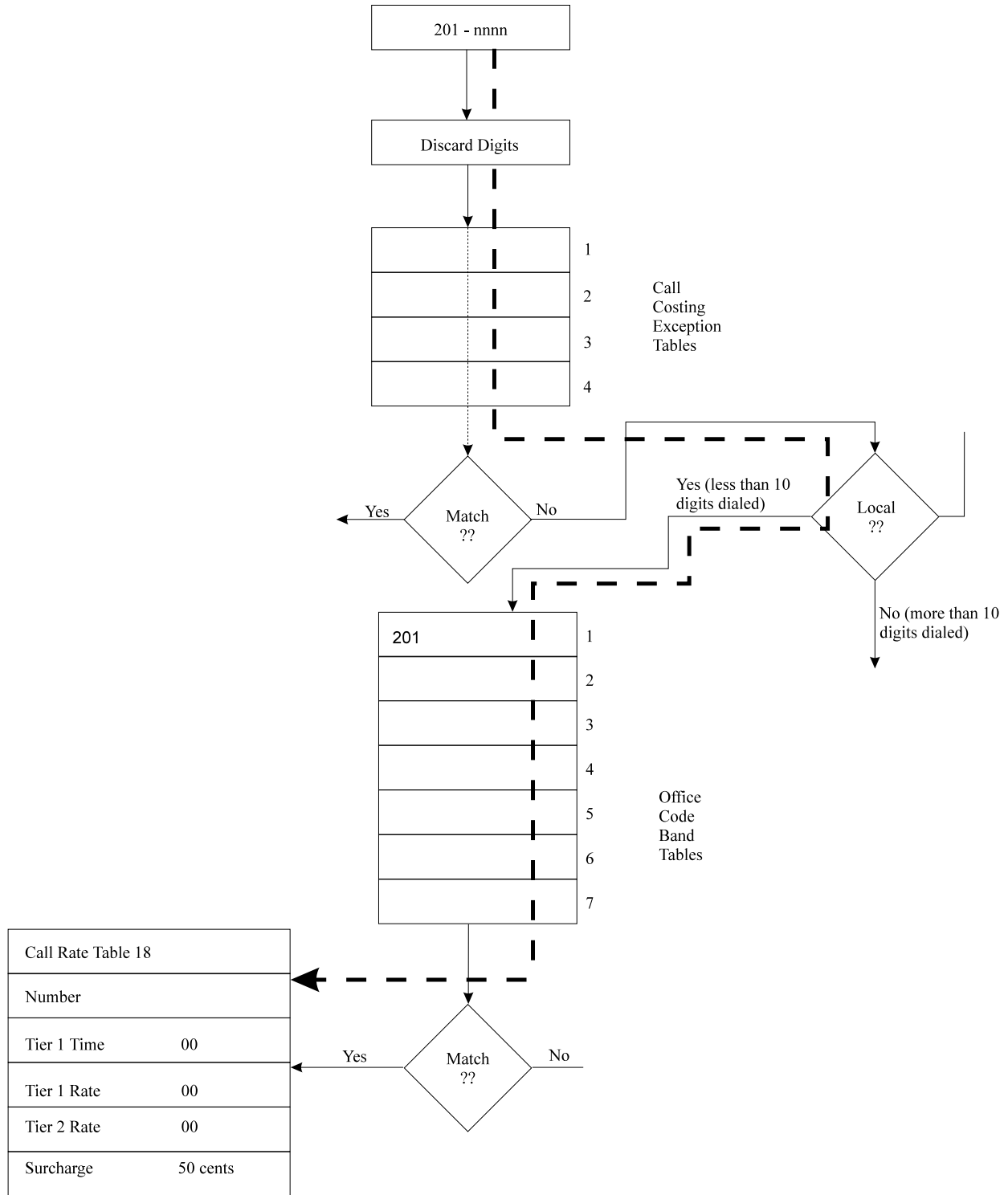

CHART2

Example B For Long Distance With Office Code Dialing Sequence (1-201-201-nnnn)

The illustrated sequence is a long distance call (more than 10 digits) with 201 as both the area code and the office code. Program call rate table 25 to cost calls of this sequence. Also, program the zone call band table by adding office code 201 to area code 201 in band one. Add any other office codes (for example 478) to area code 201 in band one as required.

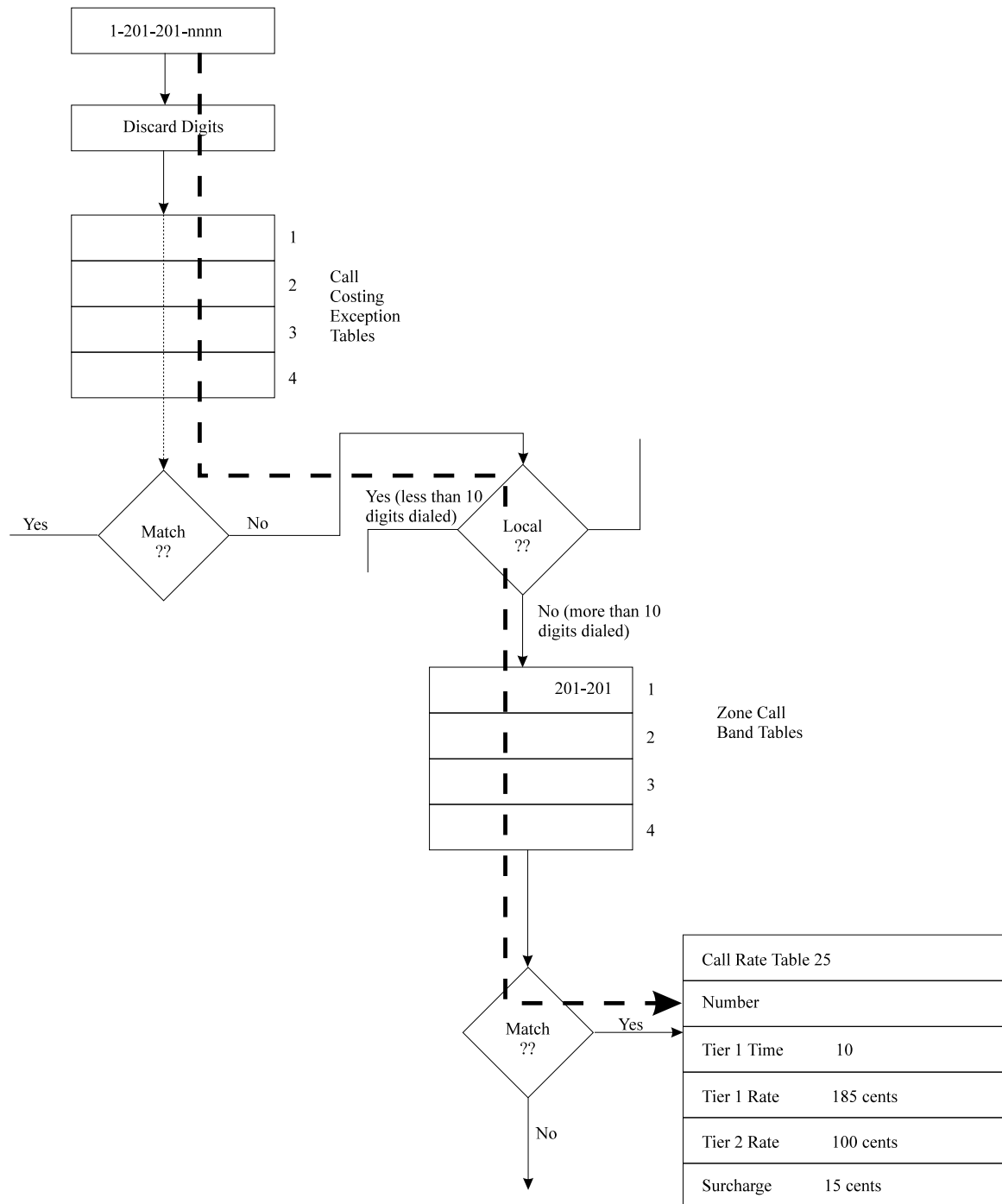

CHART3

Example C For Long Distance Dialing Sequence (1-201-nnn-nnnn)

This illustrated sequence is a long distance call (more than 10 digits) with 201 as the area code. Program call rate table 11 to cost calls in this sequence. Also, program the area code band table by adding area code 201 to band one.

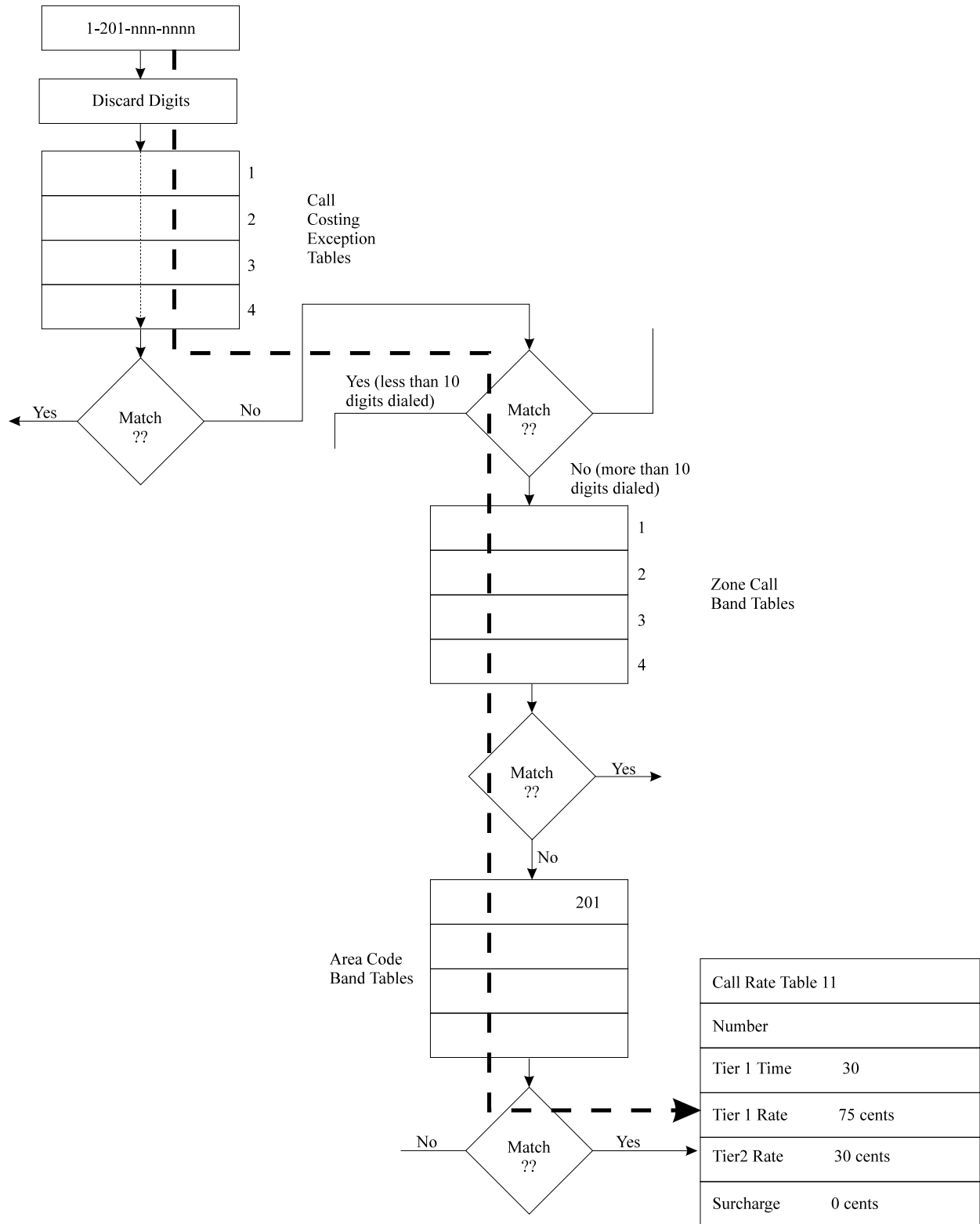
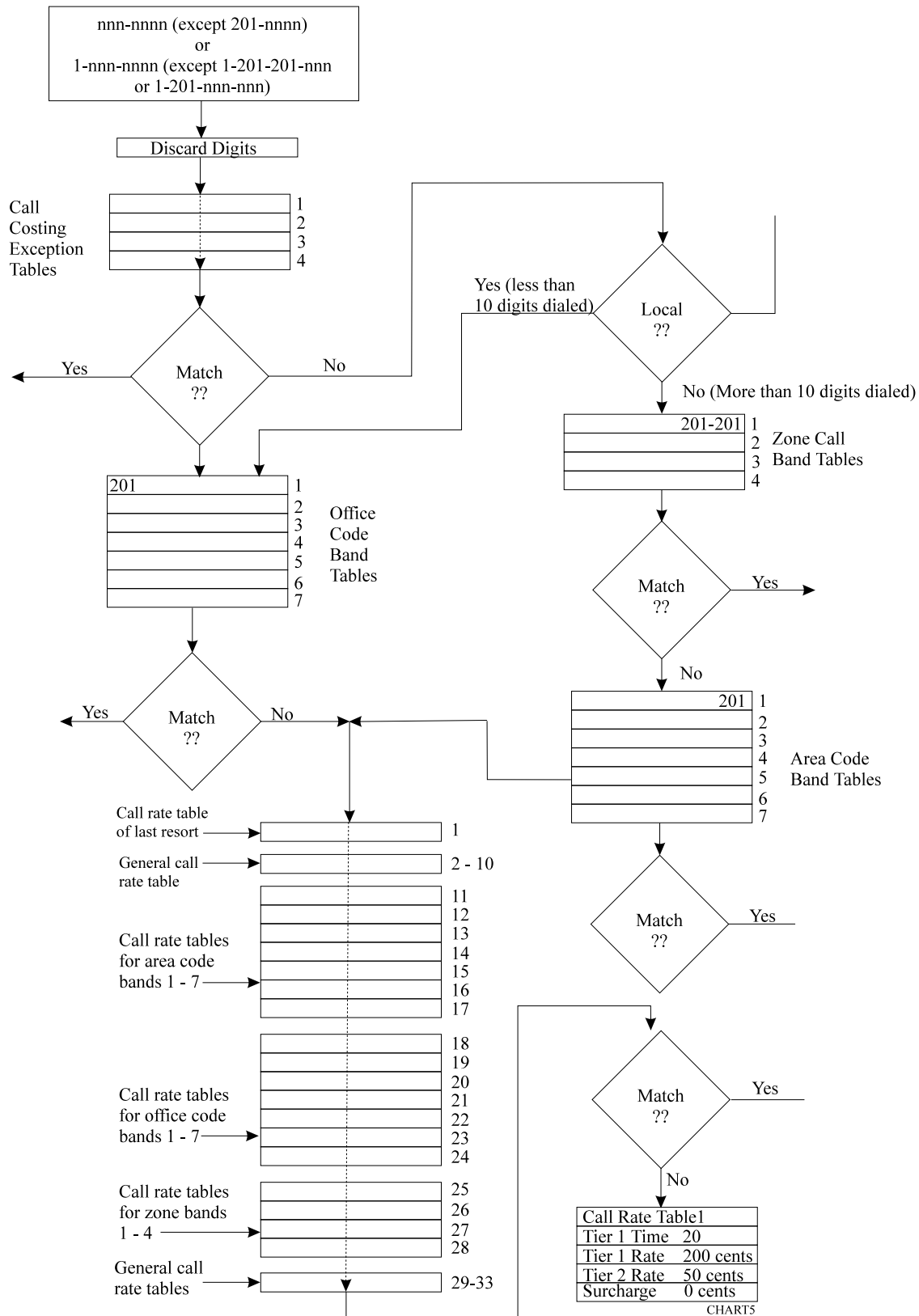

CHART4

Example D For Exception Dialing Sequence (nnn-nnnn, 1-nnn-nnnn)

Program call rate table one to cost calls that do not match any other programmed call rate table.



Typical SMDR Call Report For The Call Costing Examples

10	1	12/28/90 16:05	0.9	2014567	\$0.50 (see note 1)
10	1	12/28/90 16:06	1.8	12017894567	\$1.35 (see note 3)
10	1	12/28/90 16:08	1.5	12014785693	\$1.12 (see note 3)
10	1	12/28/90 16:11	1.5	2012014563	\$2.50 (see note 2)
10	2	12/28/90 16:12	0.5	5551212	\$1.00 (see note 4)
10	1	12/28/90 16:13	1.1	2012013	\$0.50 (see note 1)

Note 1: Costed by rate table 18

Note 2: Costed by rate table 25

Note 3: Costed by rate table 11

Note 4: Costed by rate table 1

Typical SMDA Call Report For The Call Costing Examples

Station Report for Extension -10

Date : 12/28/90 Time : 16:15

DATE	TIME	STATION	ACCOUNT	LENGTH	COST	I/O	RING	LINE	NUMBER
12/28	16:05	10		0.9	\$0.50	0		1	2014567
12/28	16:06	10		1.8	\$1.35	0		1	12017894567
12/28	16:08	10		1.5	\$1.12	0		1	12014785693
12/28	16:11	10		1.5	\$2.50	0		1	2012014563
12/28	16:12	10		0.5	\$1.00	0		2	5551212
12/28	16:13	10		1.1	\$0.50	0		1	2012013
TOTALS:			5.8	\$6.97				INCOMING	0
AVERAGES:			0.9	\$1.16				OUTGOING	6
								TOTAL CALLS	6

3.16.2 Exception Tables (Local Calls And Long Distance Calls)

Description: The system compares all calls to entries in four exception tables (one entry per table). These tables provide the first priority level of costing. The system searches these tables on a first match basis. This means that the first programmed entry that matches the call is the one that the system uses. It does not make a search for the best possible match. The system costs the matched calls using the rates that you program into the call rate tables that you assign to the exception tables. You can provide very specific exceptions to a bracket of calls similar to the following example.

Example: With all calls to area code 804 costed at a particular rate, make an exception for 804-555-1212 by programming exception table 1 with that number. Since exception table entries are the highest priority, the values in the call rate table assigned to exception table 1 are applied to all calls made to the 804-555-1212 number.

To Program:

1. Dial **78**. *“EXCEPTION TBL”*
2. Dial **1-4** for entry 1-4. *“ENTRY X”*
3. Dial **1** to assign the call rate table. *“CALL COST TBL XX”*
4. Dial **01-33** for call rate table number.
5. Dial *****.
6. Dial **2** to assign matching digits. *“XXXXXXXXXXXXXXXXXX”*
7. Dial **#** to clear current entry.
8. Dial matching digits
(16 digits maximum, # = match anything). *“XXXXXXXXXXXXXXXXXX”*
9. Dial ****** for next entry, and repeat steps 2-9 until you have made all entries.
10. Dial ******* for configuration mode.

To change setting, repeat procedure and make different selection.

3.16.3 Office Code Band Tables (Local Calls)

Description: The system measures the number of dialed digits in calls that do not match exception tables. It compares calls with numbers that have less than 10 digits (local calls) to entries that you have made in office code banding tables. Office code band tables are the second priority level of costing for local calls. They provide a means for you to assign local office codes into different bands and apply a separate call costing rate table to each band. Bands 1-7 are associated with call rate tables 18-24 respectively. Use office code band tables to cost calls made within a specific area code but to sites located at different geographic distances from the calling location.

Example: A telephone company exchange consists of office codes 976, 977, and 978. Office code 976 is assigned to an outlying area while office codes 977 and 978 are assigned to the heart of the city. Assign 977 and 978 to one office code band table and 976 to another one. Program a special call costing rate for each banding table. Then, the system costs the calls that users make to 976-nnnn at a different rate than it costs the calls that users make to 977-nnnn or 978-nnnn.

- To Program:**
- | | |
|---|----------------------------|
| 1. Dial 75 . | <i>“SMDA PROGRAMMING”</i> |
| 2. Dial 01 to program costing bands. | <i>“COSTING BANDS”</i> |
| 3. Dial 1 to program office code bands. | <i>“OFFICE CODE BANDS”</i> |
| 4. Dial 0 to assign no band | <i>“NO BAND”</i> |
| —OR— | |
| dial 1-7 for bands 1-7. | <i>“BAND X”</i> |
| 5. Dial 200-999 to assign office code. | |
| 6. Dial # and repeat step 5 for additional code. | |
| 7. Dial * and repeat steps 4-6 to program next band. | |
| 8. Dial ** for next SMDA feature | |
| —OR— | |
| dial *** for configuration mode. | |

To change setting, repeat procedure and make different selection.

3.16.4 Zone Call Band Tables (Long Distance Calls)

Description: In certain heavily populated geographic areas, different area codes exist within the same geographic distance (zone) from the calling location. In these cases, use zone call band tables to cost calls based upon the zone, or geographic distance, from the calling location.

The system measures all calls that do not match exception tables for the number of digits that the user dials. It then compares those calls with numbers that have 10 digits or more (long distance calls) to entries that you make in the zone call band tables. Zone call band tables are the second priority level of costing for long distance calls. They assign office codes and corresponding area code into different zones and apply a separate call costing rate table to each zone. Zone call band tables 1-4 are associated with call rate tables 25-28. A call must match both the office code and area code of an entry before the system costs it by a zone call band table.

Example: Zone 1 contains area code 203 with office codes 445 and 456. It also contains area code 412 with office code 508. Zone 2 contains area code 203 with office code 545. Zone 2 also contains area code 412 with office code 654. Zone 1 is costed at one rate and zone 2 is costed at another rate. A call made to 1-203-445-nnnn, 1-203-456-nnnn, or 1-412-508-nnnn is costed at a different rate than a call made to 1-203-545-nnnn or 1-412-654-nnnn.

- To Program:**
- | | |
|--|---------------------------|
| 1. Dial 75 . | <i>“SMDA PROGRAMMING”</i> |
| 2. Dial 01 to program costing bands. | <i>“COSTING BANDS ”</i> |
| 3. Dial 3 to program zone call bands. | <i>“ZONE BANDS”</i> |
| 4. Dial 0 if no zone is to be assigned.
—OR— | <i>“NO ZONE”</i> |
| dial 1-4 for zones 1-4. | <i>“ZONE X”</i> |
| 5. Dial 200-999 to assign an area code. | |
| 6. Dial # . | |
| 7. Dial 200-999 to assign an office code. | |
| 8. Dial # and repeat step 7 for another office code. | |
| 9. Dial * and repeat steps 3-9 to add another area code to same zone or to program next zone. | |
| 10. Dial ** for next SMDA feature
—OR— | |
| dial *** for configuration mode. | |

To change setting, repeat procedure and make different selection.

3.16.5 Area Code Band Table (Long Distance Calls)

Description: The system compares the long distance calls that do not match entries in zone call band tables to entries that you have made in area code band tables. Area code band tables are the third priority level of costing for long distance calls. Area code band tables 1-7 are associated with call rate costing tables 11-17. Use area code band tables to cost calls based upon the area code of the called number. Assign any or all area codes nnn (200-999) to one of seven different bands. Group area codes into bands based on frequently called areas, distance from the caller, or any other desired category.

Example: Assign area codes 703 and 804 to area code band table 1. Assign area code 415 to area code band table 7. Calls made to numbers such as 1-703-nnn-nnnn and 1-804-nnn-nnnn are costed with values assigned to call rate table 11. Calls made to numbers such as 1-415-nnn-nnnn are costed with values assigned to call rate table 17.

- To Program:**
- | | |
|--|-------------------------|
| 1. Dial 75 . | “SMDA PROGRAMMING” |
| 2. Dial 01 to program costing bands. | “COSTING BANDS ” |
| 3. Dial 2 to program area code bands. | “AREA CODE BANDS” |
| 4. Dial 0 if no band is to be assigned.
—OR—
dial 1-7 for bands 1-7 . | “NO BAND ”
“BAND X ” |
| 5. Dial 200-999 to assign area code. | |
| 6. Dial # and repeat step 6 for additional code. | |
| 7. Dial * and repeat steps 3-6 to program next band. | |
| 8. Dial ** for next SMDA feature
—OR—
dial *** for configuration mode. | |

To change setting, repeat procedure and make different selection.

3.16.6 Call Rate Tables (Local And Long Distance Calls)

Description: The system compares local calls and long distance calls that do not match entries in any exception table, office code band table, zone call band table or area code band table with the entries that you have made in call rate tables 2–10 and 29–33. It then costs those calls with the rates assigned to the call rate tables with the entries that matches the dialed numbers.

Costing by call rate table is the third priority level of costing for local calls and the fourth priority level of costing for long distance calls. You can use the call rate tables to cost any calls that require special or extraordinary rates such as 1-800-555-1212 or 1-900-976-nnnn.

When you make entries in the call rate tables, enter digits that match digits in the numbers that users dial from their stations. You can program a maximum of 16 digits into each call rate table. Since a dialed number must match all of the digits that you have entered into a table before the system recognizes a match, you can program # characters into a table in place of a specific digits to serve as “match anything” digits. This feature eliminates the need for entering every number in a series of numbers that you wish to cost at a special rate (for instance, 1900#####).

If the system can not match a dialed number with entries that you have made in the call rate tables, it costs that call with the rate that you have assigned to call rate table 1 (the table of last resort for costing all calls).

Office code band tables = call rate tables 18–24

Zone call band tables = call rate tables 25–28

Area code band tables = call rate tables 11–17

Table 3–9: Call Rate Table Programming Example

Program step 2 from Section 3.16.6	Call rate table = 33
Program step 5 from Section 3.16.6	Entry number = 19009762525
Program step 7 from Section 3.16.6	Tier 1 time = 30 (30 minutes)
Program step 9 from Section 3.16.6	Tier 1 rate = 120 (\$1.20)
Program step 11 from Section 3.16.6	Tier 2 rate = 75 (\$.75)
Program step 13 from Section 3.16.6	Surcharge = 50 (\$.50)

- To Program:**
1. Dial **76**. "CALL COST TBL "
 2. Dial table number (**01-33**). "CALL COST TBL XX"
 3. Dial **1** to enter matching digits. "XXXXXXXX "

NOTE: *Call Cost Table 1 will not accept matching digits.*

4. Dial # to clear previous digits.
5. Dial matching digits for costed number
(16 max. # = match anything digit). "XXXXXXXX "
6. Dial * to end matching digits.

NOTE : *Dialing a 00 or a 000 as an entry in steps 7, 9, 11, and 13 will clear the current entry for those steps.*

7. Dial **2** then dial **01-99** for Tier 1 time in tenths of minutes. "TIER 1 TIME XX "
8. Dial *.
9. Dial **3** then dial **001-999** for Tier 1 rate in cents. "TIER 1 RATE XXX "
10. Dial *.
11. Dial **4** then dial **001-999** for Tier 2 rate in cents. "TIER 2 RATE XXX "
12. Dial *.
13. Dial **5** then dial **001-999** for surcharge rate in cents. "SURCHARGE XXX "
14. Dial * * to program next call cost table and repeat steps 2-14 until all tables are entered.
15. Dial * * * for configuration mode.

To change setting, repeat procedure and make different selection.

3.16.7 Discard Digits

Description: When the digital telephone system is installed behind a host system such as a PBX or CENTREX, users must dial access codes before obtaining an outside line dial tone. To ensure that the system costs a call on just the actual telephone number that the user dials, you should arrange for the system to ignore these access codes. You can program up to six different access codes entries with up to eight digits per entry.

Example: If the system is installed behind a PBX using a 9 as an outside line access code, program a 9 as the discard digit. When a number such as 9-555-1212 is dialed, the 9 is discarded and the call is costed based on 555-1212.

- To Program:**
1. Dial **75**. *“SMDA PROGRAMMING”*
 2. Dial **01** to program costing bands. *“COSTING BANDS”*
 3. Dial **4** to program discard digits. *“DISCARD DIGITS”*
 4. Dial **1-6** to select entry 1-6. *“ENTRY X”*
 5. Dial **#** for no discard digits
—OR—
dial up to eight discard digits and then dial **#**. *“XXXXXXXX”*
 6. Dial ***** and repeat steps 4-5 to program next discard digit entry.
 7. Dial ****** for next SMDA feature
—OR—
dial ******* for configuration mode.

To change setting, repeat procedure and make different selection.

3.16.8 Dialing Time And Answer Time

Dial Time Limit

Description: The system does not include dialing time when it records the time of a call for costing. You can program the amount of time that the system ignores for dialing purposes.

- To Program:**
- | | |
|--|--------------------|
| 1. Dial 75 . | “SMDA PROGRAMMING” |
| 2. Dial 02 to program dial time limit. | “DIAL TIME XXX” |
| 3. Dial time in tenths of a minute
(001-999 or dial 000 to clear). | “XXXX” |
| 4. Dial * for next SMDA feature
—OR—
dial * * for configuration mode. | |

To change setting, repeat procedure and make different selection.

Answer Time Limit

Description: You can program the system to wait for a period of time before beginning to record costs for a call. This answer time allows a call to ring and be answered by the called party before the system costs it.

- To Program:**
- | | |
|--|--------------------|
| 1. Dial 75 . | “SMDA PROGRAMMING” |
| 2. Dial 03 to program answer time limit. | “ANSWER TIME XXX ” |
| 3. Dial time in tenths of a minute
(001-999 or dial 000 to clear). | “XXX ” |
| 4. Dial * for next SMDA feature
—OR—
dial * * for configuration mode. | |

To change setting, repeat procedure and make different selection.

3.16.9 LCD Speakerphone Display of Costed Calls

Description: When you arrange the digital telephone system to cost the calls, you should also arrange for the LCD speakerphones being employed with the system to display the cost of each call the user make from that station.

- To Program:**
1. Dial **53**. *“STATION FEATURES”*
 2. Dial **27**. *“LCD CALL COST”*
 3. Select station ports for programming
—Station 10-57 = Dial **10-57** or press **C10-C57**.
 4. Dial * for next station feature
—OR—
dial * * for configuration mode.

To clear current setting, repeat procedure.

3.17 Specialized Route Access (SRA)

The SRA feature allows the system to select a line group based on the digits the user has dialed. By doing this, it matches calls with their ideal routes. The feature provides a table-driven routing scheme where the numbers the users dial cause the system to choose a line group after comparing the dialed number with entries in an office code table, and area code table or, four special area code tables.

You should make a record in Chapter 4 of all programming decisions that you make—it will help you keep track of what you have done and will help you troubleshoot any problem that might arise later.

CAUTION

You can only program the SRA feature from the VDT and not from station 10.

Line group dialing codes 81, 82, and 83 do not provide access to the SRA feature, but they could provide a means of bypassing SRA, allowing users access to line groups outside of the specialized routing process. To ensure that the system routes all calls through SRA, use the feature inhibit programming procedure described in section 3.14.4 to inhibit dialing codes 81, 82, 83.

The first step in the VDT programming sequence is to enter password. Do this by typing **I*746***. Once in the programming mode, type a selection number from the main menu and follow the screen prompts to complete your programming requirements.

3.17.1 Enable The SRA Feature

Description: When you enable the SRA feature, you must first clear all assigned prime line, idle line preference, and direct line appearance to inhibit all direct line access for the system stations, and you must assign lines to the line groups the system will use.

- To Program:**
1. Type **I * 7 4 6 *** and press **RETURN**.
 2. From the main menu, type **1** and press **RETURN** for system COS menu.
 3. From the system COS menu, type **16** for specialized route access menu and press **RETURN**.
 4. From specialized route access menu, type **1** for SRA feature and press **RETURN**.
 5. Type **1** to enable or type **0** to disable SRA feature and press **RETURN**.
 6. To return to the main menu, press and hold **CTRL** and type **C**.

3.17.2 Enable SRA Office Code And Area Code Tables

Description: The office code table matches a dialed office code with one of the office codes that you have entered in the table, and routes the call over the line group that you have entered for that office code. The area code table matches a dialed area code with one of the area codes that you have entered in the table, and routes the call over the line group that you have entered for that area code.

NOTE: *When programming the tables, note that all table entries are defaulted to line group 1; therefore, to minimize programming effort, assign area/office codes with the fewest entries to line groups 2 through 4. For example: if you are entering area codes 200 through 299 and codes 200 through 209 requires one line group while codes 210 through 299 requires another line group, leave line group 1 assigned to the larger quantity of entries that require the most programming effort (210-299) and reprogram the line group for the smaller quantity of entries.*

Office Code Table

- To Program:**
1. Type **I * 7 4 6 *** and press **RETURN**.
 2. From the main menu, type **1** and press **RETURN** for system COS menu.
 3. From the system COS menu, type **16** for specialized route access menu and press **RETURN**.
 4. From specialized route access menu, type **2** for office code table menu and press **RETURN**.
 5. Type **1-4** for line group to match office codes and press **RETURN**.
 6. Type office code(s) for routing over programmed group number and press **RETURN**.
(type nnn or nnn.nnn.nnn.nnn for one code or several codes) or type **ALL** to assign every office code from 000 through 999).
 7. To return to the main menu, press and hold **CTRL** and type **C**.

Area Code Table

- To program:**
1. Type **I * 7 4 6 *** and press **RETURN**.
 2. From the main menu, type **1** and press **RETURN** for system COS menu.
 3. From the system COS menu, type **16** for specialized route access menu and press **RETURN**.
 4. From specialized route access menu, type **3** for area code table menu and press **RETURN**.
 5. Type **1-4** for line group to match area codes and press **RETURN**.
 6. Type area code(s) for routing over programmed group number and press **RETURN**. (type **nnn** or **nnn,nnn,nnn,nnn** for one code or several codes or type **ALL** to assign every area code from 000 through 999).
 7. To return to the main menu, press and hold **CTRL** and type **C**.

3.17.3 Enable Special SRA Area Code Tables

Description: The four special area code tables must first match a dialed area code and then match the dialed office code with office code entries in the matched table. With a complete match found, the system routes the call over the line group that you have assigned to the matched office code in the matched special area code table.

NOTE: *When programming the special area code tables, note that all office code entries are defaulted to line group 1; therefore, to minimize programming effort, assign those codes with the fewest entries to line groups 2 through 4. For example: if you are programming for code entries 200 through 299, and codes 000 through 209 requires one line group while codes 210 through 299 requires another line group, leave line group 1 assigned to the larger quantity of entries that require the most programming effort (210-299) and reprogram the line group for the smaller quantity of entries.*

Assigning the Special Area Codes

To Program: To assign the special area codes to the four tables,

1. Type **I * 7 4 6 *** and press **RETURN**.
2. From the main menu, type **1** and press **RETURN** for system COS menu.
3. From the system COS menu, type **16** for specialized route access menu and press **RETURN**.
4. From specialized route access menu, type **6** to assign area code to special table and press **RETURN**.
5. Type **1-4** to choose special table 1-4 and press **RETURN**.
6. Type specific area code for table and press **RETURN**.
7. Repeat steps 4 through 5 for each remaining special table and press **RETURN**.
8. To clear the special area code tables if needed
 - type **7** and press **RETURN**
 - type **1-4** for table 1-4
 - press **RETURN**, and repeat as necessary.
9. Return to the system COS menu.

Assigning line groups to the special office code entries,

- To Program:**
1. From the system COS menu, type **16** for specialized route access menu and press **RETURN**.
 2. From specialized route access menu, type **4** for special area code table menu and press **RETURN**.
 3. Type **1-4** for special table 1-4 and press **RETURN**.
 4. Type **1-4** to choose line group 1-4 and press **RETURN**.
 5. Type all office code(s) that require call routing over the line group that you set in step 4, and press **RETURN** (type nnn or nnn.nnn.nnn.nnn for one code or several codes or type **ALL** to assign every office code from 000 through 999).
 6. Type **4** and repeat steps 3 through 5 to add additional line groups to office codes in the same table or to program the next special area code table.
 7. To return to the main menu, press and hold **CTRL** and type **C**.

3.17.4 Insert Digits For SRA

Description: You may program the system, on a per line group basis, to insert up to 8 digits before a dialed number. This feature is useful if the dialed number must match a specific format for the group being used. You may insert numbers 0–9, *, #, or P for pause.

- To Program:**
1. Type **I * 7 4 6 *** and press **RETURN**.
 2. From the main menu, type **1** and press **RETURN** for system COS menu.
 3. From the system COS menu, type **16** for specialized route access menu and press **RETURN**.
 4. Type **8** for assign insert digit menu and press **RETURN**.
 5. Type **1–4** for line group number and press **RETURN**.
 6. Type SRA insert digits. (You may use a maximum of 8 digits. Digits may include 0–9, *, #, and P for pause.)
Press **RETURN**.
 7. Repeat steps 4–6 to assign insert digits for each line group.
 8. To clear the insert digits if needed
—type **9** and press **RETURN**
—type **1–4** for line group number and press **RETURN** and repeat as necessary.
 9. To return to the main menu, press and hold **CTRL** and type **C**.

3.17.5 SRA Overflow Line Group

Description: You can assign an overflow line group that the system can route calls over when no lines are free in the line group assigned to the matching entry; otherwise, the system will return busy tone to the caller when this condition exists.

NOTE: *If you arrange for the system to insert digits on a particular line group, an overflow group will take on the characteristics of the line group that is rolling over to it including the insert digits.*

- To Program:**
1. Type **I * 7 4 6 *** and press **RETURN**.
 2. From the main menu, type **1** and press **RETURN** for system COS menu.
 3. From the system COS menu, type **16** for specialized route access menu and press **RETURN**.
 4. From specialized route access menu, type **5** for overflow line group and press **RETURN**.
 5. Type **1-4** for line group 1-4 or **0** for no line group. Press **RETURN**.
 6. To return to the main menu, press and hold **CTRL** and type **C**.

3.17.6 SRA Wait Time

Description: Once a caller begins to dial digits, he or she has a certain period of time in which to dial each new digit. After the caller has stopped dialing digits and the end of the time-out period has occurred, the system analyzes the dialed digits and routes the call by following the table-driven routing scheme. Use this procedure to select the SRA wait time.

- To Program:**
1. Type **I * 7 4 6 *** and press **RETURN**.
 2. From the main menu, type **1** and press **RETURN** for system COS menu.
 3. From the system COS menu, type **16** for specialized route access menu and press **RETURN**.
 4. Type **10** for assign SRA wait time menu and press **RETURN**.
 5. Type **2, 3, or 4** for 2, 3, or 4 seconds and press **RETURN**.
 6. To return to the main menu, press and hold **CTRL** and type **C**.

3.18 **Station Message Detail Accounting/Reporting (SMDA/SMDR)**

The system produces five different call cost reports for printing:

1. Detailed report of all stations.
2. Detailed report of all accounts.
3. Trunk summary report.
4. Department summary report.
5. All records.

The system generates reports automatically for printing whenever it detects that its records storage area is 95 percent full. You can use class of service programming to choose the reports that you want the system to generate. It generates the reports for printing in the order that you selected and at a certain time each day. You can also take programming action that causes the system to delete all printed records except for those it collects during the printing operation. It stores these records for later printing.

You should make a record in Chapter 4 of all programming decisions that you make—it will help you keep track of what you have done and will help you troubleshoot any problem that might arise later.

NOTE: *A lighted LED next to the programming button for the selection indicates the current configuration. When a single button provides a toggle (on/off) action, the lighted LED indicates the active feature.*

The first step in any programming sequence is to enter the base level. Once in this mode, you can dial the feature code for any desired configuration. Enter the base level with the following procedure: press **INTERCOM** then dial ***# 7 4 6 ***. When you want to end the programming, press the **SPEAKER** button to end the programming procedure and return the system to normal operation.

3.18.1 SMDA Department Numbers

Description: Use this programming feature to define different SMDA department numbers

- To Program:**
1. Dial **75**. *“SMDA PROGRAMMING”*
 2. Dial **04** to define department numbers. *“SMDA DEPARTMENTS”*
 3. Dial **1-8** for department 1-8. *“DEPT X”*
 4. Dial **0000-9999** for department number. *“DEPT X YYYY”*
 5. Dial * for next department, and repeat steps 3-7 until all departments are numbered.
 6. Dial * * for next SMDA feature.
 7. Dial * * * for configuration mode.
- To change setting, repeat procedure and make different selection.

3.18.2 SMDA Station Assignment

Description: Assign stations to the departments so that SMDA call cost reports will only include information concerning that specific station arrangement.

- To Program:**
1. Dial **53**. *“STATION FEATURES”*
 2. Dial **22**. *“SMDA DEPARTMENTS”*
 3. Dial **0** for no SMDA department *“DEPARTMENT 0”*
—OR—
dial **1-8** for dept 1-8. *“DEPARTMENT X”*
 4. Select stations for SMDA department (LED On = Selected)
—Station **10-57** = Dial **10-57** or press **C10-C57**.
 5. Dial * for additional department/station assignments
—OR—
dial * * for next station feature
—OR—
dial * * * for configuration mode.

To change setting, repeat procedure and make different selection.

3.18.3 SMDA Printout

Automatic SMDA Reports

Description: Call cost reports, produced by the system for printing, are generated automatically whenever the system detects that the records storage area is ninety-five percent full. Program the system to automatically generate these reports for printing at a certain time each day if desired.

- To Program:**
1. Dial **75**. *“SMDA PROGRAMMING”*
 2. Dial **13** for auto report time *“AUTO TIME XXXX”*
 —Dial new time in hours and minutes (HH MM in 24 hour time) or dial * to accept current time. To clear the time dial **0000**.
 3. Dial **14** for report definition. *“AUTO REPORT ”*
 4. Choose reports for printing.
 - Dial **1** for station report *“STATION REPORT”*
 - Dial **2** account report *“ACCOUNT REPORT”*
 - Dial **3** line report *“LINE REPORT”*
 - Dial **4** department report *“DEPT. REPORT”*
 - Dial **5** print all *“PRINT RECORDS”*
 - Dial **6** delete records *“DELETE RECORDS”*
 - Dial **7** for DCD report. *“DCD REPORT”*
 5. Dial * for next SMDA feature
 —OR—
 dial * * for configuration mode.

To change setting, repeat procedure and make different selection.

SMDA Report Printout

Description: You can command the system to print several different types of SMDA reports and to delete all stored SMDA records.

NOTE: *The departmental call distribution report reflects statistics based on current departmental station assignments. Before you use the previous programming feature to reassign stations to different departments, it is a good practice to:*
(1) print the departmental call report and any other desired SMDA reports,
(2) make any desired reassignments, (3) delete all SMDA records.

To Program:	1. Dial 07 .	“SMDA REPORTS”
	2. Choose report for printout	
	—Dial 1 # for all stations	“STATION REPORT”
	—Dial 1, 10-57 , # for one station	“STATION REPORT”
	—Dial 2 # for all lines	“TRUNK REPORT”
	—Dial 3 # for SMDA department	“DEPT. REPORT”
	—Dial 4 # for account code	“ACCOUNT REPORT”
	—Dial 5 # for auto report.	“AUTO REPORT”
	—Dial 6 # for all records	“PRINT RECORDS”
	—Dial 7 # to delete records	“DELETE RECORDS”
	—Dial 0 # for DCD report	“DCD REPORT”
	—Dial 8 to obtain the number of free records remaining in system	“FREE RECS XXXXX”
	—Dial 9 to abort printout.	“ABORT PRINT”
	3. Dial * for configuration mode.	

3.18.4 SMDR Printout

SMDR Printout As System Collected

Description: With this programming step, SMDR provides continuous printout of system-wide station call activity as it is collected by the system.

- To Program:**
1. Dial **77**.
 2. Dial **2**. *“SMDR PRINT XXX”*
 3. Press **A1** to toggle between enable and disable (A1 LED On = Enabled)
—OR—
dial **1** to enable printing *“SMDR PRINT ON”*
dial **2** to disable printing. *“SMDR PRINT OFF”*
 4. Dial ***** for configuration mode.

To change setting, repeat procedure and make opposite selection.

SMDR Cost Reporting

Description: Programming action adds the cost of each reported call to the SMDR printout.

- To Program:**
1. Dial **77**. *“SMDR PRINT ”*
 2. Dial **1**. *“XXXXXXX COSTING ”*
 3. Press **A1** to toggle between enable and disable (A1 LED On = Enabled)
—OR—
dial **1** to enable *“WITH COSTING ”*
dial **2** to disable. *“WITHOUT COSTING ”*
 4. Dial ***** for configuration mode.

To change setting, repeat procedure and make opposite selection.

3.18.5 SMDA Records Deleted By The Attendant

Description: This programming step gives the attendant station the ability to delete SMDA records when commanded to do so by its user. During day-to-day system operation, when SMDA records exceed storage capacity, the attendant can delete current records to make room for additional ones if you perform this programming step. Typically the attendant would do this after he or she has requested the system to print an SMDA report. If you have set the system to delete the records after it has generated an automatic report, you usually do not need to give the attendant this manual deletion feature.

- To Program:**
1. Dial **18**. *“ATTN DELETE XXX”*
 2. Press **A1** to toggle between enable and disable (LED On = Enable)
—OR—
dial **1** to Enable *“ATTN DELETE ON”*
dial **2** to Disable. *“ATTN DELETE OFF”*
 3. Dial ***** for configuration mode.

To change setting, repeat procedure and make opposite selection.

3.19 Toll Restriction Tables

The toll restriction feature uses entries that you make in 16 different tables to prohibit some or all stations from calling a wide range of number combinations. In order for toll restriction to take effect, you must complete the following three-fold process:

- you must program entries in one or more toll tables,
- you must assign toll tables to all appropriate lines,
- you must assign toll tables to all appropriate stations,
- After you program the toll tables and assign them to both a line and the station that uses that line, the system activates the programmed toll restriction at the station.

You should make a record in Chapter 4 of all programming decisions that you make—it will help you keep track of what you have done and will help you troubleshoot any problem that might arise later.

NOTE: *A lighted LED next to the programming button for the selection indicates the current configuration. When a single button provides a toggle (on/off) action, the lighted LED indicates the active feature.*

The first step in any programming sequence is to enter the base level. Once in this mode, you can dial the feature code for any desired configuration. Enter the base level with the following procedure: press **INTERCOM** then dial * # 7 4 6 *. When you want to end the programming, press the **SPEAKER** button to end the programming procedure and return the system to normal operation.

3.19.1 Assign Entries To Toll Restriction Tables

Description: Plan and execute system toll restriction in the sequence detailed in the following steps.

1. Determine the types of dialing restrictions that you wish imposed on the system. Typically, this includes access codes which result in toll charges, and certain local numbers as desired.
2. If you wish the restricted dialing codes to be imposed consistently on most or all stations in the system, list them on one or two tables. If you must allow for a wide variation in the dialing restrictions, spread the listing out across several tables.
3. Strategically group the listings on the tables so that a list of restrictions can be applied to a particular station or group of stations.
4. Designate each table as a DENY table or as an ALLOW table. The system prevents the dialing of numbers entered in a DENY table. ALLOW tables take precedence over DENY tables. Therefore, an entry in an allow table will provide an explicit exception to an entry in a DENY table. Note that the system always permits the dialing of any number not explicitly denied. Also, note that the system will not toll restrict system speed dial numbers unless you specify them to be restricted with a separate programming step.

Example A: Provide a simple and broad toll restriction format by creating a DENY table with two entries: ENTRY (1) = 1; ENTRY (2) = 0. This format prevents all long distance and operator calls.

Example B: Prevent the dialing of all numbers within the (804) area code, while allowing the dialing of one specific number within that area code. by entering 1804 in a DENY table and 18049782200 in an ALLOW table.

5. Press the # button in place of a particular digit to condense a range of numbers into one entry. The # character is a “match-anything” digit, and can be included in an entry in either a DENY table or an ALLOW table.

Example A: If 357, 377, 387, and 397 dialing is to be prohibited, list one entry of 3#7 on a DENY table to cover them all.

Example B: Since area codes typically have a 1 or a 0 as a middle digit, prevent long distance calls to those area codes by entering 1#1# and 1#0# in an DENY table.

6. Since it is important that emergency numbers never be restricted, always create an allow table with entries of 911 and 1911 to override any DENY tables that you have created.
7. If the system is installed behind a PBX, include an access code as part of every table entry.
8. The system defaults two toll restriction tables with preprogrammed values and assigns them to the lines. You need only to assign them the stations to put them into effect. The preprogrammed values are as follows:

Default Toll Restrictions

Table 1 = Deny	Table 2 = Allow
Entry 1 = 1	Entry 1 = 1800
Entry 2 = 976	Entry 2 = 911
Entry 3 = 411	
Entry 4 = 0	

3.19.2 Programming Toll Restriction Table Entries

- To Program:**
1. Dial **71**. "TOLL TABLE"
 2. Dial **01-16**
—OR—
press **A1-A14, B1, B2** for toll table **1-16**. "XXXXX TABLE Y"
 3. Establish an allow or a deny table (A1 LED on = allow, A2 LED On = deny)
—Dial **5** or press **A1** for allow "ALLOW TABLE Y"
—Dial **6** or press **A2** for deny. "DENY TABLE Y"
 4. Dial **1-4** or press **A8-A11** for entry number 1-4. "XXXXXX"
 5. Dial **#** to clear current entry.
 6. Dial keypad digits (**0-9, #**) to enter numbers. "XXXXXX ..."
 7. Dial ***** for next entry and repeat steps 4-6 until all table restrictions are entered.
 8. Dial ****** for next table and repeat steps 2-7 until all tables are entered.
 9. Dial ******* for configuration mode.
- To change setting, repeat procedure and make different selection.

3.19.3 Assign Toll Restriction Tables To Lines

Description: Once you have created the toll restriction tables, assign them to lines.

- To Program:**
1. Dial **72**. *“ASSIGN TOLL-LINE”*
 2. Dial **01-16** or press **A1-A14, B1, B2** for toll table 1-16.
 3. Dial **#** to finish entry and display lines.
 4. Select line ports (LED On = Lines selected to receive tables)
 - Line port 1-16 = Dial **01-14** or Press **A1-A14**
 - Line port 15, 16 = Dial **15, 16** or Press **B1, B2**
 - Line port 17-24 = Dial **17-24** or press **HOLD** then dial **A1-A8**.
 5. Dial ***** and repeat steps 2-4 for next toll table to line assignment
 - OR—
 - dial ****** for configuration mode.
- To clear current setting, repeat procedure.

3.19.4 Assign Toll Restriction Tables To Stations

Description: Once you have created the toll restriction tables, assign them to stations.

- To Program:**
1. Dial **73**. *“ASSIGN TOLL-STA.”*
 2. Dial **01-16** or press **A1-A14, B1, B2** for tables 1-16 (LED On = Selected table).
 3. Dial **#** to finish entry.
 4. Select station ports (LED On = station ports to receive tables)
 - Station 10-57 = Dial **10-57** or press **C10-C57**.
 5. Dial ***** for next toll table to station assignment.
 - OR—
 - dial ****** for configuration mode.
- To clear current setting, repeat procedure.

3.19.5 Assign Toll Restriction Tables To Stations For Night Transfer (of ringing)

Description: Toll tables assigned with this feature have an effect only when the attendant places the telephone system in the night transfer (of ringing) mode of operation.

- To Program:**
1. Dial **74**. *“ASSIGN TOLL-NITE”*
 2. Dial **01-16** or press **A1-A14, B1, B2** for toll tables 1-16 (LED On = Selected table).
 3. Dial # to finish entry.
 4. Select station ports (LED On = station ports to receive tables)
—Station 10-57 = Dial **10-57** or press **C10-C57**.
 5. Dial * for next toll table to night answer assignment
—OR—
dial * * for configuration mode.

To clear current setting, repeat procedure.

3.19.6 Assign Toll Restriction Tables To System Speed Dial Calls

Description: When you enable this feature, the system applies toll restriction tables that you have assigned to a station to the system speed dial calls that users make from that station.

- To Program:**
1. Dial **53**. *“STATION FEATURES”*
 2. Dial **05**. *“SYS SPD TOLL RST”*
 3. Select station ports (LED On = station ports assigned)
—Station 10-57 = Dial **10-57** or press **C10-C57**
 4. Dial * for next station feature
—OR—
dial * * for configuration mode.

To clear current setting, repeat procedure.

3.19.7 Assign Toll Restriction Override (TRO) Code

Description: The TRO feature allows users to override the toll restriction that they encounter at other stations with their own station's toll restriction assignments. In programming for this feature, create a four-digit TRO code that users can dial to override the toll restrictions of any station that they happen to be using and replace it with a toll restriction that matches their home station.

NOTE: *The system marks outgoing line calls that users make after entering a TRO code with a (T) in its SMDR/SMDA printouts. The station number that it prints is that of the overriding station and not the actual station that the call was made from.*

To Program:

1. Dial 53 for station features.	“STATION FEATURES”
2. Dial 25 for toll restriction override codes.	“TOLL R. OVERRIDE”

NOTE: *If you are programming with a DSS/BLF console, notice that it's status LEDs turn on to indicate stations that have an assigned TRO code (C10-C57 = station ports 10-57).*

3. Select station port
—Station 10-57 = dial **10-57** or press **C10-C57**
(LED flashes = selected station port, display shows TRO if assigned).
4. Type four-digit TRO code. “NNNN”
5. Repeat steps 3 and 4 for next station port.
6. Dial * for configuration mode.

To remove a TRO code, repeat steps 1 through 3, select station port, press #.

3.19.8 Positive Disconnect Supervision

Description: When a station is on line with an outside caller and the caller hangs up, the CO may send a positive disconnect signal to the DSU II. You can enable the positive disconnect supervision feature on a per-line basis. If you enable positive disconnect supervision, when the system receives the CO's positive disconnect signal, the system resets the toll restriction, releases the current call record, and creates a new call record in its place.

- To Program:**
1. Dial 48. *“DIS. SUPERVISION”*
 2. Select line ports for disconnect supervision (LED On = lines selected to receive tables).
 - Line port 1-14 = Dial **01-04** or press **A1-A14**
 - Line port 15, 16 = Dial **15, 16** or press **B1, B2**
 - Line port 17-24 = Dial **17-24** or press **HOLD** then press **A1-A8**.
 3. Dial * for configuration mode.

3.20 The Tracker Paging System

The optional Tracker Paging System allows users to send alpha/numeric or numeric-only messages to Tracker pagers assigned to station extension numbers. The type of message that the system delivers depends upon the model Tracker Pager being used.

You should make a record of all programming decisions that you make—it will help you keep track of what you have done and will help you troubleshoot any problem that might arise later.

NOTE: *A lighted LED next to the programming button for the selection indicates the current configuration. When a single button provides a toggle (on/off) action, the lighted LED indicates the feature is active.*

The first step in any programming sequence is to enter the base level. Once in this mode, you can dial the feature code for any desired configuration. Enter the base level with the following procedure: press **INTERCOM** then dial ***#746***. When you want to end the programming, press the **SPEAKER** button to end the programming procedure and return the system to normal operation.

3.20.1 Enabling The Tracker Paging System

Description: Use this procedure to enable the Tracker Paging System feature as a system-wide feature.

- To Program:**
1. Dial **17**. "SYSTEM FEATURES"
 2. Dial **06**. "TRACKER XXXXXX"
 3. Press **A1** to toggle between enable or disable (LED On = Enabled)
—OR—
dial **1** to Enable (A1 LED On) "TRACKER ENABLED"
dial **2** to Disable.
 4. Press ****** for configuration mode. "TRACKER DISABLED"
- To change setting, repeat procedure and make opposite selection.

3.20.2 Enabling Tracker Pagers For Stations

Description: After you have enabled the Tracker Paging System as a system-wide feature, enable the Tracker pagers at individual stations. Station users can disable a Tracker Pager by pressing **INTERCOM #06** or enable a Pager by pressing **INTERCOM *06**.

- To Program:**
1. Dial **53**. "STATION FEATURES"
 2. Dial **37**. "DISPLAY PAGER"
 3. Enable Tracker pager operation
—Dial **10-57** or press **C10-C57** (LED On = Enabled).
 4. Press ****** for configuration mode.
- To clear current setting, repeat procedure.

NOTE: *The Pager's ID must be programmed to correspond to a DSU station number. Pager programming must be done through the Tracker base station. Refer to the "Program Mode" section of IMI89-138, Operating Instructions For The Tracker Paging System.*

3.20.3 Setting The Data Parameters

Description: You must set the data parameters of the data port where you connect Tracker to 9600 baud, eight data bits, one stop bit, and no handshaking to ensure proper Tracker operation.

NOTE: *The Tracker base station must also be programmed for 9600 baud so that it matches the DSU setting. The default Tracker base station baud setting is 9600; however, if you want to check or change the baud setting in the base station, refer to section V, “Software Configuration,” of 68P81101B25-O, Alphanumeric Interface Option.*

To Program:

1. Dial **15**. “BAUD RATE”
2. Dial **1** for port A
3. Dial **0811** for data parameters.
4. Press ****** for configuration mode.

3.21 Digital Voice Announcing (DVA)

Digital voice announcing uses a hardware peripheral device (product code DVA01) connected to a digital station port to play pre-recorded announcements and messages during an in-progress call. The DVA stores the pre-recorded messages in its memory for recall when needed. While the DVA is not automatic, it enhances the following features by providing automated voice prompts and dialing instructions to callers; direct department call with department calling distribution (DCD), direct inward station dialing (DISD), and Tracker Paging System. Before you can enhance the DCD or DISD features, you must completely program them using instructions earlier in this chapter. Refer to section 3.11, *Configuring The Direct Department Calling* for DCD programming information. Refer to section 3.12, *Configuring The Direct Inward Station Dialing* for DISD programming.

You should use chapter 4, *SystemRecords* to record the programming decisions that you make—it will help you keep track of what you have done and will help you troubleshoot any problem that might arise later.

NOTE: *A lighted LED next to the programming button for the selection indicates the current configuration. When a single button provides a toggle (on/off) action, the lighted LED indicates the active feature.*

The first step in any programming sequence is to enter the base level. Once in this mode, you can dial the feature code for any desired configuration. Enter the base level with the following procedure: press **INTERCOM** the dial ***#746***. When you want to end the programming, press the **SPEAKER** button to end the programming procedure and return the system to normal operation.

3.21.1 Programming For DCD Operation

Description: When you plan to enhance DCD operation with the DVA, you must first completely program the system for DCD operation.

To Program: To enable the system for DCD operation, refer to the instructions in section 3.11, *Direct Department Calling* and complete the following steps:

1. Assign direct department dialing access code (often referred to as a department pilot number).
2. Assign direct department calling line ports.
3. Assign direct department calling station ports.
4. Refer to the instructions in section 3.7.6, *Call Forward On Busy/Ring No-Answer*, and program the department stations to have ring no-answer call forwarding.
5. Use the procedure described immediately below, and program the DCD department transfers before disconnect.

3.21.2 DCD Department Transfers Before Disconnect

Description: Because the system will continue transferring a call back to a department after a recall to DVA time-out has occurred, you can set the number of transfer times that occur before the system drops the call.

- To Program:**
1. Dial **17**. *“SYSTEM FEATURES”*
 2. Dial **10**. *“DEPT XFR X”*
 3. Choose 1–9 transfer times or set system to always transfer.
(LED On = Enabled)

—Dial 1 or press A1	<i>“DEPT XFR 1”</i>
—Dial 2 or press A2	<i>“DEPT XFR 2”</i>
—Dial 3 or press A3	<i>“DEPT XFR 3”</i>
—Dial 4 or press A4	<i>“DEPT XFR 4”</i>
—Dial 5 or press A5	<i>“DEPT XFR 5”</i>
—Dial 6 or press A8	<i>“DEPT XFR 6”</i>
—Dial 7 or press A9	<i>“DEPT XFR 7”</i>
—Dial 8 or press A10	<i>“DEPT XFR 8”</i>
—Dial 9 or press A11	<i>“DEPT XFR 9”</i>
—Dial 0 or press A12	<i>“NEVER DISCONNECT”</i>
 4. Press ****** for configuration mode.
To change setting, repeat procedure and make different selection.

3.21.3 Programming For DISD Operation

Description: When you plan to enhance DISD operation with the DVA, you must first completely program the system for DISD operation.

NOTE: *You should set a DISD dial time that is as long as the maximum time needed to complete the longest DVA message. For example, if the longest DVA message is 60 seconds, set the DISD dial time to 60 seconds. If the DISD dial time is longer than the DVA message, the message will repeat itself. If the DISD dial time is shorter than the DVA message, the message will not finish.*

To Program: To enable the system for DISD operation, refer to section 3.12, *Direct Inward Station Dialing Configuration*, and complete the following steps:

1. Program the dial time limit.
2. Assign a DISD Assist station.
3. Program the DISD Incoming Rings.
4. Program inhibit DISD digit dialing.

3.21.4 Enabling/Disabling Digital Voice Announcing (DVA)

Description: You can enable DVA support for both DISD and DCD operation.

To Program: To assign DVA support for DISD operation.

1. Dial **17**. *“SYSTEM FEATURES”*
 2. Dial **07**. *“DISD DVA XXXXXXXX”*
 3. Press A1 to toggle between enable and disable (LED on = Enable)
—OR—
Dial **1** to Enable (A1 LED is on) *“DISD DVA ENABLE”*
Dial **2** to Disable. *“DISD DVA DISABLE”*
 4. Press ** for configuration mode.
- To change setting, repeat procedure and make opposite selection.

To Program: To assign DVA support for DCD operation.

1. Dial **17**. *“SYSTEM FEATURES”*
 2. Dial **08**. *“DCD DVA XXXXXXXX”*
 3. Press A1 to toggle between enable and disable (LED On = Enable).
—OR—
Dial **1** to Enable (A1 LED is on) *“DCD DVA ENABLE”*
Dial **2** to Disable. *“DCD DVA DISABLE”*
 4. Press ** for configuration mode.
- To change setting, repeat procedure and make opposite selection.

3.21.5 Programming The DVA Messages

Description: You or the system attendant can store the customized messages in the DVA device in one of two ways: by delivering them from the telephone handset at station 10 or 12 or by playing the contents of a professionally-supplied tape recording into the DVA memory. The DVA provides up to four unique messages. The total available message time is two minutes for one message if needed. Because of the time constraints, it is a good practice to script your messages ahead of time so that you can read them aloud in a clear and concise manner as you store them in the DVA memory.

The voice prompt messages fall into four categories:

Day Answer Messages

For DCD callers—"Welcome to Acme's sales department, all of our agents are busy. Please stay on the line and an agent will answer your call as soon as possible."

For DISD callers—"Welcome to Acme's Company. If you know your party's extension, dial it now; otherwise, stay on the line and an attendant will answer your call."

Night Answer Messages

For DCD callers—"Welcome to Acme's sales department. Our hours are eight to four-thirty. Please call tomorrow during those hours."

For DISD callers—"Welcome to Acme Company. Our hours are eight to four-thirty. Please call tomorrow during those hours."

Recall Messages

For DCD callers—"Please hold. An agent will be with you as soon as possible."

For DISD callers—"The party you have called is not available. Please dial a new extension number."

For DISD callers to systems that have the Tracker Paging System installed—"The party you have called is not available. Please dial a new extension number or dial # plus your call-back number followed by another # to page your party."

Drop Message

"Thanks for calling Acme, good bye."

- To Program:**
1. Dial **08**. "DVA TABLE NUM"
 2. Choose the message style.
—Dial **1** for DISD message style. "PORT NUMBER"
—Dial **2** for DCD message style. "PORT NUMBER"
 3. Select DVA station ports
—Dial **10-57** or press **C10-C57** (LED On = Selected).
 4. Press **#** to end DVA station port entry. "DVA MESSAGES"
 5. Press **0** to erase all four messages.
 6. Dial code for message type you wish to record
—Dial **5** to record day answer message
—Dial **6** to record night answer message
—Dial **7** to record recall message
—Dial **8** to record drop message
—Dial **9** to stop recording.
 7. Record the messages using either step a or step b, described below. Note the length of time for the message. Remember, the maximum allowed time for messages is two minutes.
 - a. Read the message aloud into the telephone handset mouthpiece.
—OR—
 - b. Start the audio tape recorder and play the pre-recorded message.
 8. Press **9** and repeat steps 6-7 for each message.
 9. Dial code to listen to your recorded messages.
—Dial **1** to play day answer message.
—Dial **2** to play night answer message.
—Dial **3** to play recall message.
—Dial **4** to play drop message.
—Dial **9** to stop playback.
 10. To record or play messages for another DVA, press ***** and repeat steps 2-8.
 11. When finished, press **SPEAKER** to end.

NOTE: *You should set a DISD dial time that is as long as the maximum time needed to complete the longest DVA message. For example, if the longest DVA message is 60 seconds, set the DISD dial time to 60 seconds. If the DISD dial time is longer than the DVA message, the message will repeat itself. If the DISD dial time is shorter than the DVA message, the message will not finish.*

3.22 The Data Interface Unit

The Data Interface Unit (DIU) is a device connected to a digital station port. The DIU provides connection for a digital multiline telephone and another device such as an Industry standard telephone (IST), FAX, or modem. The DIU switches the voice path from the DSU to either the digital telephone or the IST telephone by pressing a button on the digital telephone.

When the DIU is in the digital mode, the digital telephone will function fully and the IST telephone will not function at all. When the DIU is in the IST mode, the IST functions fully and the digital telephone will not have a voice path; however, the digital telephone will continue to receive LED and LCD messages and send certain button messages.

The first step in any programming sequence is to enter the base level. Once in this mode, you can dial the feature code for any desired configuration. Enter the base level with the following procedure: press **INTERCOM** then dial ***#746***. When you want to end the programming, press the **SPEAKER** button to end the programming procedure and return the system to normal operation.

3.22.1 Programming Data Buttons

Description: After you install a data interface unit, you must program a data button on the multiline telephone connected to the DIU.

- To Program:**
1. Dial **56** for button mapping. *“BUTTON MAPPING”*
 2. Dial **18** for data button. *“ASSIGN DATA”*
 3. Select button to be programmed with data button
—press **A1–A14, B1–B10**
 4. Select station ports to be programmed
for station 10–57, dial **10–57** or press **C10–C57**.
 5. Dial ***** for next data button assignment
—OR—
Dial ****** for next button mapping feature
—OR—
Dial ******* for next configuration mode.

3.22.2 Remote Data Station

Description: Use this procedure to program the system to allow remote control of a DIU from one or more multiline digital telephones assigned to other station ports. Remote commands are blocked when the station is busy with a call.

- To Program:**
1. Dial **53** for station features. *“STA. FEATURES”*
 2. Dial **39** for data station. *“DATA STATION”*
 3. Enter data station number.
 4. Select station ports to be programmed
—for station 10–57, dial **10–57** or press **C10–C57**.
 5. Dial ***** for next station feature,
—OR—
Dial ****** for next configuration mode.

3.22.3 Creating Data Security Groups

Description: When using several DIUs, you can set up one through three data security groups. Use a security group to prevent callers outside your group from accessing IST devices, such as personal computers, within your group. Any number of stations can be put into one group. Station to station calls can still be made. By default, all stations are assigned to data security group 0 (no security group).

- To Program:**
1. Dial **53** for station features. *“STA. FEATURES”*
 2. Dial **40** for data group. *“DATA GROUP”*
 3. Dial **1–3** for data group 1–3 or dial **0** for none.
 4. Select station ports to be programmed
—for station 10–57, dial **10–57** or press **C10–C57**.
 5. Dial ***** for next data group assignment
—OR—
Dial ****** for next station feature
—OR—
Dial ******* for next configuration mode.

3.23 Caller ID Service Support

When you subscribe to Caller ID service, the central office sends Caller ID data over the lines. After the Caller ID device deciphers the data, it is displayed on a system LCD speakerphone. You must program lines and stations for Caller ID service.

NOTE: *A lighted LED next to the programming button for the selection indicates the current configuration. When a single button provides a toggle (on/off) action, the lighted LED indicates the active feature.*

Since the station receives Caller ID data between the first and second rings, you can arrange for the first ring on Caller ID lines to be either audible or silent. Selecting the silent option ensures that the Caller ID data is displayed prior to ringing, eliminating the loss of Caller ID data to premature answering.

A station user may automatically retrieve and dial the last Caller ID number displayed at his or her station by using a "SAVE" button assigned to the station.

CAUTION

Seven-, eight-, and 11-digit numbers are always dialable while 10-digit numbers must be transformed by the system before they are dialable. To arrange for the system to transform a 10-digit number into dialable format you must use the VDT programming method to program the local area code and 6-digit area/office codes into the system's memory. You can not do this from station 10 or 12.

All Caller ID features require that the customer-supplied Caller ID interface (product code CID08) deliver its data to the system's RS232 data port B. You must configure this port to match the output of the decoder device. The recommended configuration is 9600 baud, with eight data bits and one stop bit.

The system provides Caller ID information as part of the SMDR printout. An example of this appears below.

Caller ID Information On SMDR Printout

Call #	Station #	Line #	Date	Time	Call length	Answer Time	Called or Calling #	Call Cost
1	1000	12	10/15/92	04:38	0.1		123456789 0123456	\$ 0.51
2	12	3	10/15/92	00:56	0.2		5551212	
3		1	10/15/92	00:56	NOANS	.2	/5551234	
4	10	1	10/15/92	00:56	0.1	.1	/5551234	
5		4	10/15/92	01:00	NOANS	.2		
6	10	4	10/15/92	01:00	0.1	.0		
7	10	1(D)	10/15/92	04:23	0.2	.1	/5556789	\$ 0.00
8	10	1(D)	10/15/92	04:19	0.2	.1		\$ 0.00

- | | |
|--|--|
| (1) outgoing call | (5) unanswered incoming call, without Caller ID |
| (2) outgoing call | (6) answered incoming call, without Caller ID |
| (3) unanswered incoming call, with Caller ID | (7) answered incoming DISD call, with Caller ID |
| (4) answered incoming call, with Caller ID | (8) unanswered incoming DISD call, without Caller ID |

If SMDR printout is not already turned on (default), turn it on as follows:

1. Press **ITCM** and dial ***#746***.
2. Dial **772**. *"SMDR PRINT XXX"*
3. Dial **1** to enable printout. *"SMDR PRINT ON"*
4. Dial ****** for configuration mode or **SPEAKER** to quit.

As an option, you can arrange for the system to provide Caller ID data distribution through the RS232 data port B to a personal computer (PC) just as it supplies SMDA data to a data printer. This data consists of four special-purpose messages and is in the ASCII format suitable for use with PC-based application programs. The messages are as follows:

Typical Message 1—sent out as soon as Caller ID data arrives from the CO

Message ID and Identifier (3 bytes)	Line No. (2 bytes)	Caller ID Data (15 bytes)	End of Message (2 bytes)
3E 3C 31	30 35	31 2D 38 30 34 2D 39 37 38 2D 32 32 30 30 20	0D 0A
> < 1	0 1	1 — 8 0 4 — 9 7 8 — 2 2 0 0	CR LF

Typical Message 2—sent when a ringing line with CID is answered or retrieved from hold.

Message ID and Identifier (3 bytes)	Line No. (2 bytes)	Station No. (2 bytes)	End of Message (2 bytes)
3E 3C 32	31 32	31 30	0D 0A
> < 2	1 2	1 0	CR LF

Typical Message 3—sent when CID data is not received from answered line or when a line is taken off-hook

Message ID and Identifier (3 bytes)	Line No. (2 bytes)	Station No. (2 bytes)	End of Message (2 bytes)
3E 3C 33	31 35	31 32	0D 0A
> < 3	1 5	1 2	CR LF

Typical Message 4—sent when line is made idle

Message ID and Identifier (3 bytes)	Line No. (2 bytes)	End of Message (2 bytes)
3E 3C 34	30 35	0D 0A
> < 4	0 5	CR LF

3.23.1 Assigning Caller ID Lines (required programming)

Description: Programs lines to receive Caller ID service.

- To Program:**
1. Dial **47**. *“CALLER ID LINES”*
 2. Select line ports (LED On = Selected)
Line Port 1–14 = Dial **01–14** or **A1–A14**
Line Port 15, 16 = Dial **15, 16** or press **B1, B2**
Line Port 17–24 = Dial **17–24** or press **HOLD**
and then press **A1–A8**.
 3. Press * for configuration mode.

3.23.2 Assigning Caller ID Stations (required programming)

Description: Programs stations to receive Caller ID information.

- To Program:**
1. Dial **53**. *“STATION FEATURES”*
 2. Dial **36**. *“CALLER ID STA.”*
 3. Select station ports. (LED On = Selected)
—Station 10–57 = Dial **10–57** or press **C10–C57**.
 4. Press ** for configuration mode.

3.23.3 Configuring COM 2 Serial Data Port (required programming)

Description: If the COM 2 serial data port is not currently set at its default values (9600 baud, 8 data bits, and 1 stop bit) program that port to have those values so that it will receive Caller ID data.

- To Program:**
- | | |
|---|------------------------|
| 1. Dial 15 . | <i>“BAUD RATE”</i> |
| 2. Dial 2 for COM 2. | |
| 3. Press A10 for 9600 baud. | <i>“W nD nS 9600”</i> |
| 4. Dial 11 or press A14 for 8 data bits and 1 stop bit. | <i>“W 8D 1S ZZZZZ”</i> |
| 5. Dial ** for configuration mode. | |

3.23.4 Setting The Audible First Ring Feature (optional programming)

Description: Turns on the Audible First Ring feature for the system.

- To Program:**
- | | |
|---|--------------------------|
| 1. Dial 17 . | <i>“SYSTEM FEATURES”</i> |
| 2. Dial 01 . | <i>“CID FIRST RING”</i> |
| 3. Dial 1 to enable the audible first ring (LED on)
—OR—
Dial 2 to silence the first ring on Caller ID lines. | |
| 4. Press ** for configuration mode. | |

3.23.5 Setting The Caller ID Distribution (optional programming)

Description: Sends Caller ID information to data port B for access by a PC.

- To Program:**
1. Dial **17**. *“SYSTEM FEATURES”*
 2. Dial **02**. *“CID DISTRIBUTION”*
 3. Dial **1** to enable Caller ID distribution (LED on)
—OR—
Dial **2** to disable Caller ID distribution.
 4. Press ****** for configuration mode.

3.23.6 Assigning A “SAVE” Button (optional programming)

Description: Selects a “SAVE” button to display and redial the most recent Caller ID number received at a station.

- To Program:**
1. Dial **56**. *“BUTTON MAPPING”*
 2. Dial **08**. *“ASSIGN SAVE”*
 3. Select button to be programmed
—press **A1–A14, B1–B10**.
 4. Select station ports to have SAVE button (LED On = Assigned)
—station 10–57 = Dial **10–57** or press **C10–C57**.
 5. Press ******* for configuration mode.

4***System Records***

4.1	Programming Password Records	4-3
4.2	System Configuration Records	4-3
4.3	Recording The Line Configurations.....	4-11
4.4	Recording The Station Configurations	4-13
4.5	Recording The Account Code Configurations	4-19
4.6	Recording The Industry-Standard Telephone Configurations	4-21
4.7	Direct Department Calling Records.....	4-22
4.8	Direct Inward Station Dialing (DISD) Records	4-23
4.9	Recording The Voice Mail Interface Configurations	4-24
4.10	Recording The Integrated Call Costing Configurations	4-27
4.11	Station Message Detail Accounting/Reporting Records.....	4-32
4.12	Recording The Specialized Route Access Configurations.....	4-33
4.13	Recording Toll Restriction Table Configurations.....	4-37
4.13.1	Toll Restriction Tables—continued.....	4-38
4.13.2	Toll Restriction Tables—Line Assignments	4-40
4.13.3	Toll Restriction Assignments	4-41

4.14	Caller ID Service Support Configuration Chart.....	4-42
4.15	Tracker Paging System Records.....	4-44
4.16	DigitalVoice Announcing Records.....	4-45
4.17	Data Interface Unit Records	4-48
4.18	Overlay For The 7700S Telephone.....	4-49
4.19	Overlay For The 7714X And 7714S Telephones	4-51
4.20	Overlay For The 7714X, 7714S, And 7700S Telephones	4-53
4.21	Overlay For The 8024S And 8124 Telephones	4-55
4.22	Overlay For The 8012S And 8112S Telephones.....	4-57
4.23	Overlay For The DD32X-xx.....	4-59
4.24	Overlay For The IB64X.....	4-61
4.25	Overlay For Impression Telephone.....	4-63
4.26	Over For Impression DSS/BLF Console.....	4-65

4.1 Programming Password Records

Password Description	Default Password	Customized Password					
VDT Installer	I*746*						
VDT Administrator	I *236*						
Station 10 Installer	INTERCOM *#746*						
Station 10 Administrator	INTERCOM *#236*						

4.2 System Configuration Records

Automatic Station Relocation	
Enable	Disable
<i>Default = Disable</i>	

Do Not Disturb Inhibit System-Wide	
Enable	Disable
Do Not Disturb Override Stations (10-57)	
DND Button (A1-A14, B1-B10)	
<i>Default = Inhibit enabled, no override assigned, no DND button.</i>	

Exclusive Hold	
Enable	Disable
<i>Default = Enabled</i>	

Data Baud Rate	
110 Baud	
150 Baud	
300 Baud	
600 Baud	
1200 Baud	
2400 Baud	
4800 Baud	
9600 Baud	
19200 Baud	
7 Data/2 Stop Bits	
8 Data/1 Stop Bits	
<i>Default = 9600 Baud, 8 Data Bits, 1 Stop Bit</i>	

Extended DTMF Tones For Automatic Dialing	
60 msec	
80 msec	
100 msec	
120 msec	
160 msec	
240 msec	
320 msec	
400 msec	
480 msec	
560 msec	
720 msec	
880 msec	
1040 msec	
<i>Default = 80 msec</i>	

System Alarm Reporting	
Enable	Disable
<i>Default = Disable</i>	

Station Monitoring		
Visual Ring Indication	Enable	Disable
Audible Ring Indication Stations (10-57)		
<i>Default = Visual indication disabled, no audible indication assigned.</i>		

Tandem Attendant	
Enable	Disable
<i>Default = Disable</i>	

Tone or Voice Signaling	
Voice	Tone
<i>Default = Tone</i>	

SOHVA Tone Bursts	1	2	3	4	5	6
<i>Default = 6</i>						

PA Options				
Direct Ringing Lines (1-24)				
Delayed Ringing Lines (1-24)				
Night Ringing Lines (1-24)				
Zone Paging Enabled	Zone 1	Zone 2	Zone 3	All-Call
Relay Port Relay Tracking	Station 17		Paging Port	
PA Port Signal Tone	Intercom		DTMF	
<i>Defaults = No ringing lines, all-call paging, station 17 ringing, and intercom tone.</i>				

Allow Ringer Off Option	
Enabled	Disabled
<i>Default = Enabled</i>	

LCD Messages										
Msg. No.	Location									
	1	2	3	4	5	6	7	8	9	10
1										
2										
3										
4										
5										
6										
7										
8										
9										
10										
11										
12										
13										
14										
15										
16										

Default: 1 = Back At, 2 = Call

System Speed Dial Record (Be sure to record a line group number with each speed dial number.)											
Loc	Number	Name	Loc	Number	Name	Loc	Number	Name	Loc	Number	Name
01			26			51			76		
02			27			52			77		
03			28			53			78		
04			29			54			79		
05			30			55			80		
06			31			56			81		
07			32			57			82		
08			33			58			83		
09			34			59			84		
10			35			60			85		
11			36			61			86		
12			37			62			87		
13			38			63			88		
14			39			64			89		
15			40			65			90		
16			41			66			91		
17			42			67			92		
18			43			68			93		
19			44			69			94		
20			45			70			95		
21			46			71			96		
22			47			72			97		
23			48			73			98		
24			49			74			99		
25			50			75					

Call Park Recall Time	
1 min	5 min
2 min	6 min
3 min	Never
4 min	
<i>Default = 2 minutes</i>	

Pause Time	
.5 sec	5.0 sec
1.0 sec	7.5 sec
1.5 sec	10 sec
2.0 sec	15 sec
3.0 sec	20 sec
<i>Default = 1 second</i>	

Recall/Flash Time	
.08 sec	.88 sec
.30 sec	1.0 sec
.50 sec	1.5 sec
.60 sec	2.0 sec
.75 sec	3.0 sec
<i>Default = 2 seconds</i>	

Timed Hold Recall Time	
30 sec	240 sec
60 sec	300 sec
90 sec	360 sec
120 sec	420 sec
180 sec	Never
<i>Default = 60 seconds</i>	

Unanswered Call Transfer Recall Time	
10 sec	60 sec
20 sec	90 sec
25 sec	120 sec
30 sec	180 sec
45 sec	240 sec
<i>Default = 20 seconds</i> <input type="checkbox"/> <i>For Stations</i>	

Unanswered Call Transfer Recall Time	
10 sec	60 sec
20 sec	90 sec
25 sec	120 sec
30 sec	180 sec
45 sec	240 sec
<i>Default = 20 seconds</i> <input type="checkbox"/> <i>For Departments</i>	

Delayed Ringing Delay Time	
6 sec	36 sec
12 sec	42 sec
18 sec	48 sec
24 sec	54 sec
30 sec	60 sec
<i>Default = 18 seconds</i>	

Feature Inhibit		
Feature	Disabled	Enabled
Line Group 1		
Line Group 2		
Line Group 3		
Line Group 4		
Zone 1 Paging		
Zone 2 Paging		
Zone 3 Paging		
All Call		
Meet Me Page		
Night Transfer		
Background Music		
Voice Announce Block		
Message Waiting		
Call Pickup		
Call Forward		
Automatic Call Back		
Station-to-Station Mesg.		
Line Group Queue		
Directed Station Hold		
Call Park Orbit 1		
Call Park Orbit 2		
Call Park Orbit 3		
Call Park Orbit 4		
Call Park Orbit 5		
Call Park Orbit 6		
Call Park Orbit 7		
Call Park Orbit 8		
Call Park Orbit 9		
Call Waiting		
LCD Messaging		
Executive Override / Service Observing		
Account Code		
Personal Call Forward		
Enable All Features		
<i>Default = All features enabled</i>		

4.3 Recording The Line Configurations

Feature	Line Port (Write number, name, group, or other data.)							
	1	2	3	4	5	6	7	8
Abandoned Hold Release (50/350 msec)								
Automatic Privacy (On/Off)								
Privacy Release Stations (10-57)								
Line Port Disable (On/Off)								
Line Groups (0, 1-4)								
Line Name (5 characters)								
Line Port Function (AUX/CO)								
Line To Line Port Reassignment (1/1, etc.)								
Pulse/Tone Switchable (pulse/tone)								
Voice Mail ID (6 digits max)								
<i>Default = 50 msec hold release, privacy on all with no station released, no disabled lines, no groups assigned, no names assigned, all ports co, same line/port, all tone dialing, no VM ID.</i>								

Feature	Line Port (Write number, name, group, or other data.)							
	9	10	11	12	13	14	15	16
Abandoned Hold Release (50/350 msec)								
Automatic Privacy (On/Off)								
Privacy Release Stations (10-57)								
Line Port Disable (On/Off)								
Line Groups (0, 1-4)								
Line Name (5 characters)								
Line Port Function (AUX/CO)								
Line To Line Port Reassignment (1/1, etc.)								
Pulse/Tone Switchable (pulse/tone)								
Voice Mail ID (6 digits max)								
<i>Default = 50 msec hold release, privacy on all with no station released, no disabled lines, no groups assigned, no names assigned, all ports co, same line/port, all tone dialing, no VM ID.</i>								

Feature	Line Port (Write number, name, group, or other data.)							
	17	18	19	20	21	22	23	24
Abandoned Hold Release (50/350 msec)								
Automatic Privacy (On/Off)								
Privacy Release Stations (10-57)								
Line Port Disable (On/Off)								
Line Groups (0, 1-4)								
Line Name (5 characters)								
Line Port Function (AUX/CO)								
Line To Line Port Reassignment (1/1, etc.)								
Pulse/Tone Switchable (pulse/tone)								
Voice Mail ID (6 digits max)								
<i>Default = 50 msec hold release, privacy on all with no station released, no disabled lines, no groups assigned, no names assigned, all ports co, same line/port, all tone dialing, no VM ID.</i>								

Block Programming		
Model Line Port	Start Line Port	End Line Port

4.4 Recording The Station Configurations

Use this sheet as an individual station record or as a record for a block of similarly programmed stations. You can make copies of this blank sheet as needed to meet the system capacity.

Feature	Choice	Default	Enter Station Port Numbers							
Access Denied	Lines 1-24	None								
All-Call and Zone Paging Receive	All/1-3	All								
Originate	All/1-3	All								
Audible Monitoring	None/Dir/Delay	None								
Automatic Hold	Yes/No	No								
Automatic Hold - Intercom	Yes/No	No								
Automatic Privacy Privacy Release	None/1-24	None								
Call Forward On Ring No-Answer	No/1-9 Rings	No								
Call Forward On Busy	Yes/No	No								
Call Origination Denied	No/1-24	No								
Central Message Desk	Yes/No	No								
Data Security Port	Yes/No	No								
Do Not Disturb Override	Yes/No	No								
Dual Console Feature	No/10-57	No								
Executive Override	Yes/No	No								
Flexible Ringing	Direct	1-24	All (Sta. 10, 17)							
	Delayed	1-24	None							
Night Transfer (of ringing)	1-24	All (Sta. 10, 17)								
Flexible Station Numbering	10-7999	Ext = Port								
Group Call Pickup	1-4	1								
Headset Interface	Yes/No	No								
Idle Line Preference	No/ 1-24	No								
Intercom Hunt Group	10-57	None								
Personal Ring Tones	1-6	1								
Prime	Line	1-24	None							
	Group	1-4	None							
	Intercom	Itcm.	None							
Message Waiting Originate	Yes/No	Yes								
Ringling Line Preference	Yes/No	No								
SOHVA Disable	Yes/No	No								
SOHVA Groups	None/1-8	None								
Service Observing	Yes/No	No								
Station Disable	Yes/No	No								
Station To Station Port Reassignment	10/57	Sta = Port								
System Alarm Report	Yes/No	No								
Voice Announce Blocking	Yes/No	No								

Block Programming					
Model Station Port					
First Station Port					
Last Station Port					

Button Mapping The DigiTech Telephones (Rev. I and later)

Complete one record sheet for each station.
Copy this blank record sheet as required for additional stations.

BUTTON	DESCRIPTION
BLK	Blank
Lnn	Lines 1 - 24
Snn	Stations 10 - 57
DND	Do Not Dist r
PRI	Pri a y
IC2	Se on Inter o
ACC	A ont Co e
SAV	Sa e
ZPn	Zone Page 1 - 3
AC	All-Call Page
ACB	A to ati Call Ba k
CF	Call For ar
CPn	Call Park Or it 1 -
TGn	Line Gro p 1 - 4
VAB	Voi e Anno n e Blo k
TGQ	Line Gro p Q e e

BUTTON ASSIGNMENT CHART	
A1	
A2	
A3	
A4	
A5	
A6	
A7	
A8	
A	
A10	
A11	
A12	
A13	
A14	
B1	
B2	
B3	
B4	
B5	
B6	
B7	
B8	
B	
B10	

CAJS020

PORT NUMBER	
INTERCOM NUMBER	
STATION NAME	
STATION LOCATION	
TELEPHONE	TYPE
	MODEL

7700S LCD Speakerphone

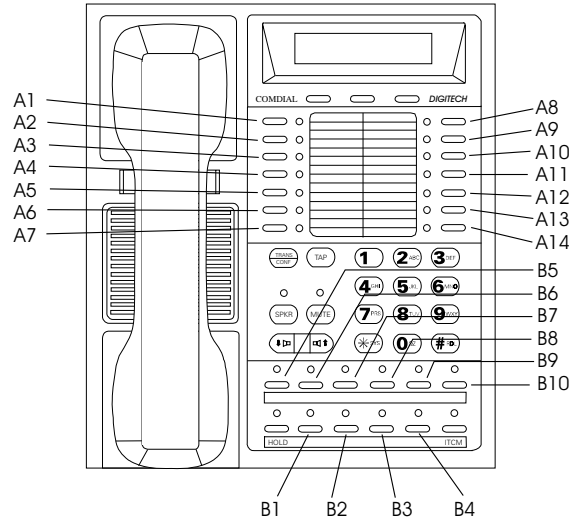

7714S Speakerphone

7714X Monitor Telephone

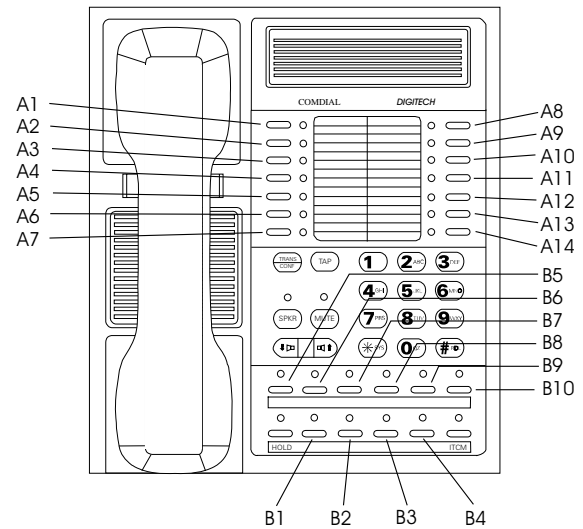

DEFAULT SETTINGS B1-B10 Line 1 - Line 10 an A1 23 A2 21 A3 1 A4 17 A5 15 A6 13
A7 11 A8 24 A 22 A10 20 A11 18 A12 16 A13 14 A14 12

Button Mapping The DigiTech Telephones (Rev. A-H)

Complete one record sheet for each station.
Copy this blank record sheet as required for additional stations.

BUTTON	DESCRIPTION
BLK	Blank
Lnn	Lines 1 - 24
Snn	Stations 10 - 57
DND	Do Not Dist r
PRI	Pri a y
IC2	Se on Inter o
ACC	A ont Co e
SAV	Sa e
ZPn	Zone Page 1 - 3
AC	All-Call Page
ACB	A to ati Call Ba k
CF	Call For ar
CPn	Call Park Or it 1 -
TGn	Line Gro p 1 - 4
VAB	Voi e Anno n e Blo k
TGQ	Line Gro p Q e e

BUTTON ASSIGNMENT CHART	
A1	
A2	
A3	
A4	
A5	
A6	
A7	
A8	
A	
A10	
A11	
A12	
A13	
A14	
B1	
B2	
B3	
B4	
B5	
B6	
B7	
B8	

PORT NUMBER	
INTERCOM NUMBER	
STATION NAME	
STATION LOCATION	
TELEPHONE	TYPE
	MODEL

7700S LCD Speakerphone

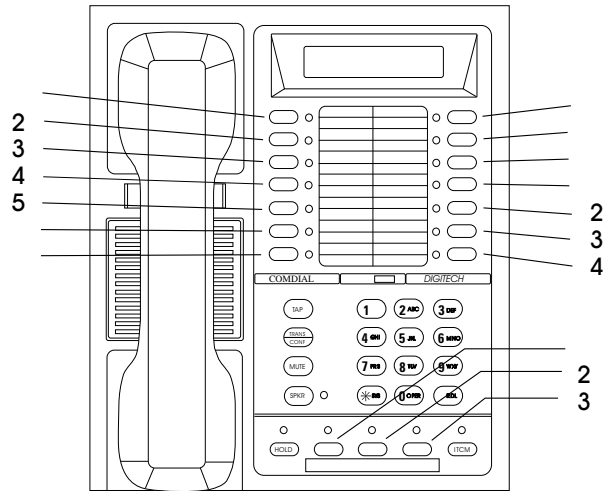

7714S Speakerphone

7714X Monitor Telephone

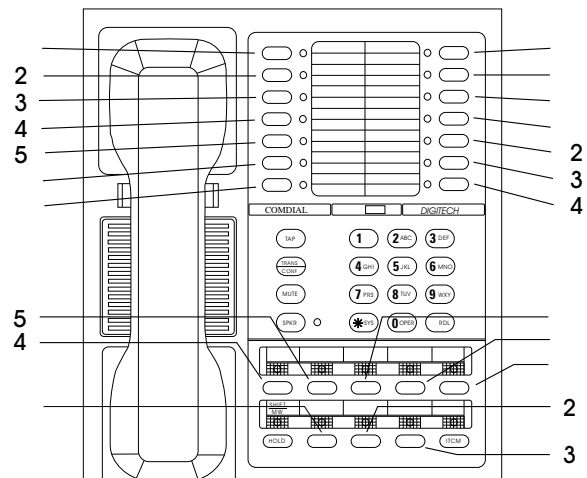

CAJS021

DEFAULT SETTINGS	B1-B8	Line 1 - Line 8	an	A1	21	A2	1	A3	17	A4	15	A5	13	A6	11
	A7	A8	22	A	20	A10	18	A11	16	A12	14	A13	12	A14	10

Button Mapping The Impact Telephones

Complete one record sheet for each station.
Copy this blank record sheet as required for additional stations.

BUTTON	DESCRIPTION
BLK	Blank
Lnn	Lines 1 - 24
Snn	Stations 10 - 57
DND	Do Not Dist r
PRI	Pri a y
IC2	Se on Inter o
ACC	A o nt Co e
SAV	Sa e
ZPn	Zone Page 1 - 3
AC	All-Call Page
ACB	A to ati Call Bak
CF	Call For ar
CPn	Call Park Or it 1 -
TGn	Line Gro p 1 - 4
VAB	Voi e Anno n e Blo k
TGQ	Line Gro p Q e e

BUTTON ASSIGNMENT CHART		
DigiTe h EQUIV	IMPACT BUTTON	PROGRAMMED ASSIGNMENT
A1	L01	
A2	L02	
A3	L03	
A4	L04	
A5	L05	
A6	L06	
A7	L07	
A8	L08	
A	L0	
A10	L10	
A11	L11	
A12	L12	
DEFAULT L1-L12		LINE 1 - LINE 12

PORT NUMBER		
INTERCOM NUMBER		
STATION NAME		
STATION LOCATION		
TELEPHONE	TYPE	
	MODEL	

8012S 12-Line LCD Speakerphone

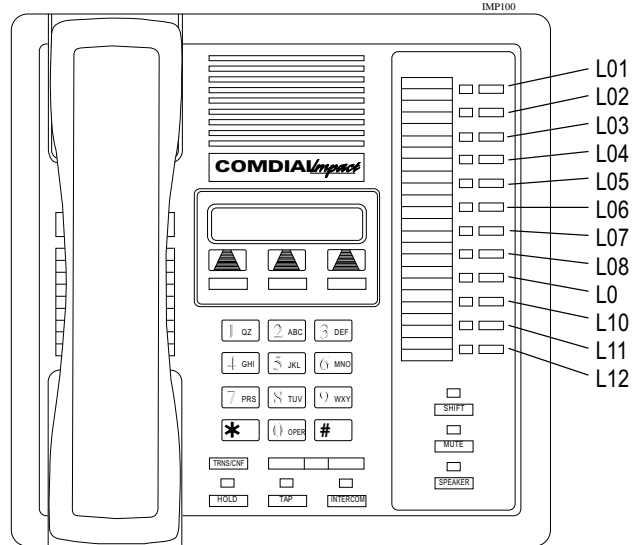

8112S 12-Line Speakerphone

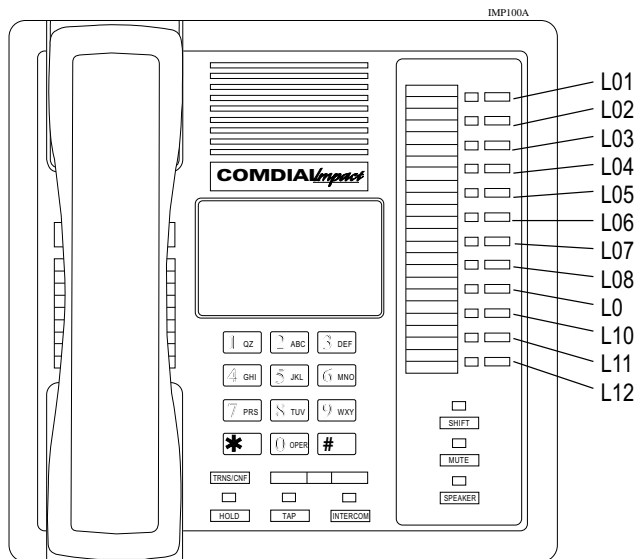

CAJS01

Button Mapping The Impact Telephones

Complete one record sheet for each station.
Copy this blank record sheet as required for additional stations.

BUTTON	DESCRIPTION
BLK	Blank
Lnn	Lines 1 - 24
Snn	Stations 10 - 57
DND	Do Not Distr
PRI	Pri a y
IC2	Se on Inter o
ACC	A ont Co e
SAV	Sa e
ZPh	Zone Page 1 - 3
AC	All-Call Page
ACB	A to ati Call Bak
CF	Call For ar
CPn	Call Park Or it 1 -
TGn	Line Gro p 1 - 4
VAB	Voi e Anno n e Blo k
TGQ	Line Gro p Q e e

BUTTON ASSIGNMENT CHART		
DigiTe h EQUIV	IMPACT BUTTON	PROGRAMMED ASSIGNMENT
A1	L01	
A2	L02	
A3	L03	
A4	L04	
A5	L05	
A6	L06	
A7	L07	
A8	L08	
A	L0	
A10	L10	
A11	L11	
A12	L12	
A13	L13	
A14	L14	
B	L15	
B10	L16	
B1	L17	
B2	L18	
B3	L1	
B4	L20	
B5	L21	
B6	L22	
B7	L23	
B8	L24	
DEFAULT		
L1-L24		LINE 1 - LINE 24

PORT NUMBER		
INTERCOM NUMBER		
STATION NAME		
STATION LOCATION		
TELEPHONE	TYPE	
	MODEL	

8024S 24-Line LCD Speakerphone

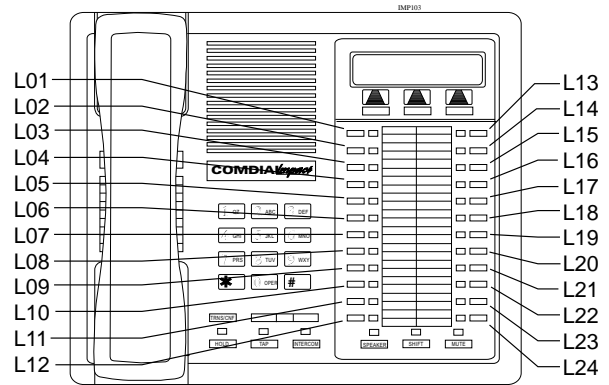

8124S 24-Line Speakerphone

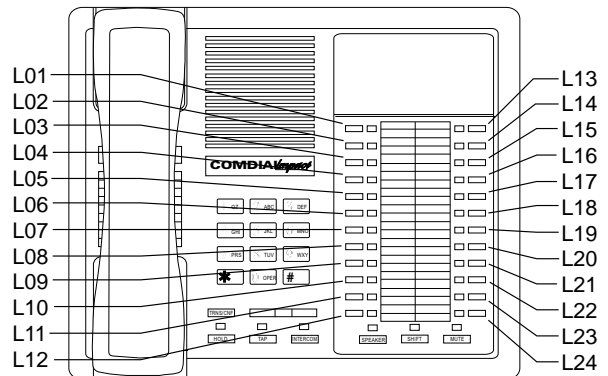

CAJS016

Button Mapping The Scout 900MX Digital Wireless Telephone

Complete one record sheet for each station.
Copy this blank record sheet as required for additional stations.

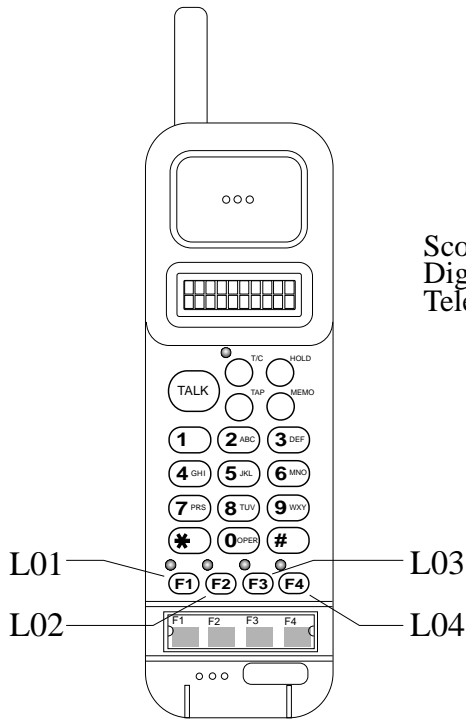

BUTTON ASSIGNMENT CHART	
L01	
L02	
L03	
L04	
<i>Default:</i>	
<i>L01 = Line 1</i>	
<i>L02 = Line 2</i>	
<i>L03 = Line 3</i>	
<i>L04 = Intercom</i>	

PORT NUMBER					
INTERCOM NUMBER					
STATION NAME					
STATION LOCATION					
TELEPHONE	<table border="1"> <thead> <tr> <th>TYPE</th> <th>MODEL</th> </tr> </thead> <tbody> <tr> <td></td> <td></td> </tr> </tbody> </table>	TYPE	MODEL		
TYPE	MODEL				

068 .

BUTTON	DESCRIPTION
BLK	Blank
Lnn	Lines 1 - 24
Snn	Stations 10 - 57
DND	Do Not Distr
PRI	Pri a y
IC2	Se on Inter o
ACC	A o nt Co e
SAV	Sa e
ZPn	Zone Page 1 - 3
AC	All-Call Page
ACB	A to ati Call Ba k
CF	Call For ar
CPn	Call Park Or it 1 -
TGn	Line Gro p 1 - 4
VAB	Voi e Anno n e Blo k
TGQ	Line Gro p Q e e

Button Mapping The Impression Telephones

Complete one record sheet for each station.
Copy this blank record sheet as required for additional stations.

2022S LCD Speakerphone

BUTTON	DESCRIPTION
BLK	Blank
Lnn	Lines 1 - 24
Snn	Stations 10 - 57
DND	Do Not Distr
PRI	Pri ay
IC2	Se on Inter o
ACC	A ont Co e
SAV	Sa e
ZPn	Zone Page 1 - 3
AC	All-Call Page
ACB	A to ati Call Ba k
CF	Call For ar
CPn	Call Park Or it 1 -
TGn	Line Gro p 1 - 4
VAB	Voi e Anno n e Blo k
TGQ	Line Gro p Q e e

BUTTON ASSIGNMENT CHART	
A1	
A2	
A3	
A4	
A5	
A6	
A7	
A8	
A	
A10	
A11	
A12	
A13	
A14	
A15	
A16	
B1	
B2	
B3	
B4	
B5	
B6	

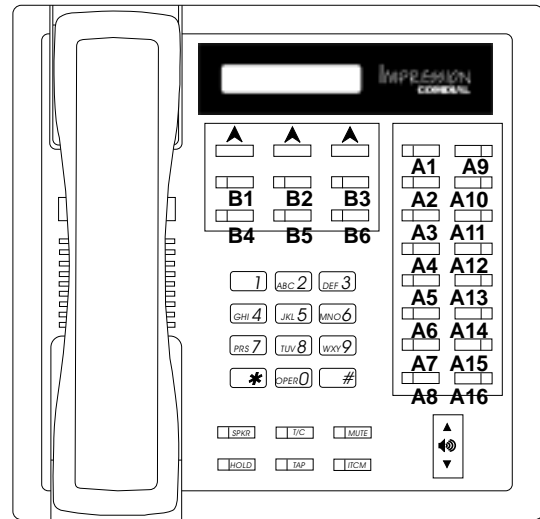

2122S Speakerphone

2122X Monitor Telephone

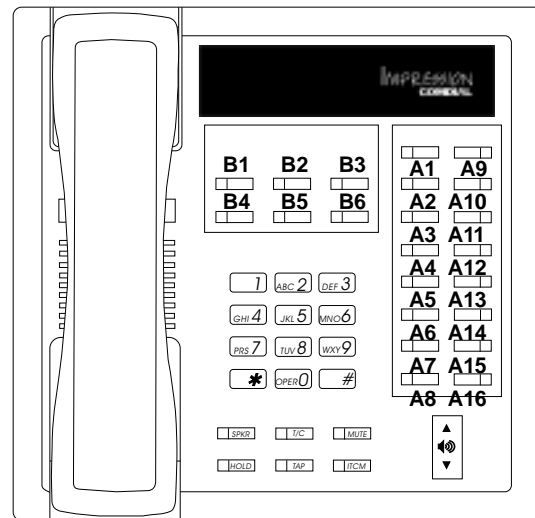

CAJS108

PORT NUMBER		
INTERCOM NUMBER		
STATION NAME		
STATION LOCATION		
TELEPHONE	TYPE	
	MODEL	

DEFAULT SETTINGS	B1-B6	Line 1 - Line 6 an	A1	7	A2	A3	11	A4	13	A5	15	A6	17					
	A7	1	A8	21	A	8	A10	10	A11	12	A12	14	A13	16	A14	18	A15	20
	A16	22																

Account Code Usage	Enabled	Disabled	
Verification	On	Off	
Usage Status	Forced	Optional	
Station Exceptions			
Verified Digits			
Account Code Length			
Emergency No. 1			
Emergency No. 2			
Emergency No. 3			
Emergency No. 4			
Emergency No. 5			
Emergency No. 6			
Emergency No. 7			
Emergency No. 8			
Emergency No. 9			
Emergency No. 10			
LCD Display Time			
Display On Incoming	Yes	No	
Default = Account Code Usage: Disabled Verified Status: On Usage Status: Forced Exceptions: None Verified Digits: Three Account Code Digits: 3 Display Time: 5 seconds Incoming Display: On			

4.6 Recording The Industry-Standard Telephone Configurations

Distinctive Ringing	
Enabled	
Disabled	
<i>Default = Enabled</i>	

Thru Dialing Port					
10		26		42	
11		27		43	
12		28		44	
13		29		45	
14		30		46	
15		31		47	
16		32		48	
17		33		49	
18		34		50	
19		35		51	
20		36		52	
21		37		53	
22		38		54	
23		39		55	
24		40		56	
25		41		57	
<i>Default = Not Enabled</i>					

4.7 Direct Department Calling Records

Department 1	
Access Code 10-7999	
Line Ports 1-24	
Station Ports 10-57	

Department 2	
Access Code 10-7999	
Line Ports 1-24	
Station Ports 10-57	

Department 3	
Access Code 10-7999	
Line Ports 1-24	
Station Ports 10-57	

Department 4	
Access Code 10-7999	
Line Ports 1-24	
Station Ports 10-57	

Default = No access code assigned, no line ports assigned, and no stations assigned.

4.8 Direct Inward Station Dialing (DISD) Records

Dial Time Limit	6 sec	9 sec	12 sec	15 sec	20 sec	30 sec	40 sec	60 sec	90 sec	0 sec
<i>Default = 12 Seconds</i>										

Assist Station	
Station Assigned	Lines Assigned
Day Station	
Night Station	
<i>Default = Station 10 Day And Night</i>	

Incoming Ring	Line Port Assigned
0	
1	
2	
4	
5	
6	
7	
8	
9	
<i>Default = 0 Rings</i>	

4.9 Recording The Voice Mail Interface Configurations

Voice Mail Station Port					
10		26		42	
11		27		43	
12		28		44	
13		29		45	
14		30		46	
15		31		47	
16		32		48	
17		33		49	
18		34		50	
19		35		51	
20		36		52	
21		37		53	
22		38		54	
23		39		55	
24		40		56	
25		41		57	

Default = Not Enabled

Automatic Attendant Ringing Lines (1-24)							
Station	Direct	Delay	Night	Station	Direct	Delay	Night
10				34			
11				35			
12				36			
13				37			
14				38			
15				39			
16				40			
17				41			
18				42			
19				43			
20				44			
21				45			
22				46			
23				47			
24				48			
25				49			
26				50			
27				51			
28				52			
29				53			
30				54			
31				55			
32				56			
33				57			
<i>Default = Not Assigned</i>							

Automatic Transfer Of Voice Mail	
Enable	
Disable	
<i>Default = Disabled</i>	

Voice Mail Line Port Identification				
1		9		17
2		10		18
3		11		19
4		12		20
5		13		21
6		14		22
7		15		23
8		16		24
<i>Default = No ID Assigned</i>				

Voice Mail Transfer On Busy Station Port				
10		26		42
11		27		43
12		28		44
13		29		45
14		30		46
15		31		47
16		32		48
17		33		49
18		34		50
19		35		51
20		36		52
21		37		53
22		38		54
23		39		55
24		40		56
25		41		57
<i>Default = Not Enabled</i>				

4.10 Recording The Integrated Call Costing Configurations

Exception Tables																	
Exception Table	Digits																Cost Table
	1	2	3	4	5	6	7	8	9	10	11	12	13	14	15	16	
1																	
2																	
3																	
4																	
<i>Default = None Assigned</i>																	

Office Code Band Tables	
Band	Office Code Prefix
1	
2	
3	
4	
5	
6	
7	
<i>Default = None Assigned</i>	

Zone Call Band Tables	
Band	
1	
2	
3	
4	
<i>Default = None Assigned</i>	

Area Code Band Tables	
Band	
1	
2	
3	
4	
5	
6	
7	
<i>Default = None Assigned</i>	

Discard Digits								
Entry	Digits							
	1	2	3	4	5	6	7	8
1								
2								
3								
4								
5								
6								
<i>Default = No Discard Digits Assigned</i>								

Dial Time Limit	
01-999 Seconds	
<i>Default = 0 Seconds</i>	

Answer Time Limit	
01-999 Seconds	
<i>Default = 0 Seconds</i>	

Call Rate Table 1	
Tier 1 Time	
Tier 1 Rate	
Tier 2 Rate	
Surcharge	

Call Rate Table 2	
Number	
Tier 1 Time	
Tier 1 Rate	
Tier 2 Rate	
Surcharge	

Call Rate Table 3	
Number	
Tier 1 Time	
Tier 1 Rate	
Tier 2 Rate	
Surcharge	

Call Rate Table 4	
Number	
Tier 1 Time	
Tier 1 Rate	
Tier 2 Rate	
Surcharge	

Call Rate Table 5	
Number	
Tier 1 Time	
Tier 1 Rate	
Tier 2 Rate	
Surcharge	

Call Rate Table 6	
Number	
Tier 1 Time	
Tier 1 Rate	
Tier 2 Rate	
Surcharge	

Call Rate Table 7	
Number	
Tier 1 Time	
Tier 1 Rate	
Tier 2 Rate	
Surcharge	

Call Rate Table 8	
Number	
Tier 1 Time	
Tier 1 Rate	
Tier 2 Rate	
Surcharge	

Call Rate Table 9	
Number	
Tier 1 Time	
Tier 1 Rate	
Tier 2 Rate	
Surcharge	

Call Rate Table 10	
Number	
Tier 1 Time	
Tier 1 Rate	
Tier 2 Rate	
Surcharge	

Call Rate Table 11	
Number	
Tier 1 Time	
Tier 1 Rate	
Tier 2 Rate	
Surcharge	

Call Rate Table 12	
Number	
Tier 1 Time	
Tier 1 Rate	
Tier 2 Rate	
Surcharge	

Call Rate Table 13	
Number	
Tier 1 Time	
Tier 1 Rate	
Tier 2 Rate	
Surcharge	

Call Rate Table 19	
Number	
Tier 1 Time	
Tier 1 Rate	
Tier 2 Rate	
Surcharge	

Call Rate Table 14	
Number	
Tier 1 Time	
Tier 1 Rate	
Tier 2 Rate	
Surcharge	

Call Rate Table 20	
Number	
Tier 1 Time	
Tier 1 Rate	
Tier 2 Rate	
Surcharge	

Call Rate Table 15	
Number	
Tier 1 Time	
Tier 1 Rate	
Tier 2 Rate	
Surcharge	

Call Rate Table 21	
Number	
Tier 1 Time	
Tier 1 Rate	
Tier 2 Rate	
Surcharge	

Call Rate Table 16	
Number	
Tier 1 Time	
Tier 1 Rate	
Tier 2 Rate	
Surcharge	

Call Rate Table 22	
Number	
Tier 1 Time	
Tier 1 Rate	
Tier 2 Rate	
Surcharge	

Call Rate Table 17	
Number	
Tier 1 Time	
Tier 1 Rate	
Tier 2 Rate	
Surcharge	

Call Rate Table 23	
Number	
Tier 1 Time	
Tier 1 Rate	
Tier 2 Rate	
Surcharge	

Call Rate Table 18	
Number	
Tier 1 Time	
Tier 1 Rate	
Tier 2 Rate	
Surcharge	

Call Rate Table 24	
Number	
Tier 1 Time	
Tier 1 Rate	
Tier 2 Rate	
Surcharge	

Call Rate Table 25	
Number	
Tier 1 Time	
Tier 1 Rate	
Tier 2 Rate	
Surcharge	

Call Rate Table 31	
Number	
Tier 1 Time	
Tier 1 Rate	
Tier 2 Rate	
Surcharge	

Call Rate Table 26	
Number	
Tier 1 Time	
Tier 1 Rate	
Tier 2 Rate	
Surcharge	

Call Rate Table 32	
Number	
Tier 1 Time	
Tier 1 Rate	
Tier 2 Rate	
Surcharge	

Call Rate Table 27	
Number	
Tier 1 Time	
Tier 1 Rate	
Tier 2 Rate	
Surcharge	

Call Rate Table 33	
Number	
Tier 1 Time	
Tier 1 Rate	
Tier 2 Rate	
Surcharge	

Call Rate Table 28	
Number	
Tier 1 Time	
Tier 1 Rate	
Tier 2 Rate	
Surcharge	

Call Rate Table 29	
Number	
Tier 1 Time	
Tier 1 Rate	
Tier 2 Rate	
Surcharge	

Call Rate Table 30	
Number	
Tier 1 Time	
Tier 1 Rate	
Tier 2 Rate	
Surcharge	

4.11 Station Message Detail Accounting/Reporting Records

Department	Department Number	Department Station
1		
2		
3		
4		
5		
6		
7		
8		
<i>Default = None Assigned</i>		

Automatic Report Time	
Hours	
Minutes	
Selected Records	
All Stations	
One Station	
Account Report	
Line Report	
Department Report	
Print All Records	
Delete Records	
DCD Report	
<i>Default = None Assigned</i>	

SMDR Cost Reporting	Enabled	Disabled
SMDR Printout	Enabled	Disabled
<i>Default = No Cost Reported, Printout Enabled</i>		

Overflow Line Group
<i>Default = None</i>

SRA Wait Time	2 seconds	3 seconds	4 seconds
<i>Default = 4 seconds</i>			

Line Group	Insert Digits							
	1	2	3	4	5	6	7	8
1								
2								
3								
4								
<i>Default = None</i>								

4.13 Recording Toll Restriction Table Configurations

Toll Restriction Table 1																
Table Type: Allow _____ Deny <i>X</i>																
Entry	Entry Number (16 Digits Maximum)															
	1	2	3	4	5	6	7	8	9	10	11	12	13	14	15	16
1	1															
2	9	7	6													
3	4	1	1													
4	0															
Table Assignment:																
Lines	ALL Stations _____															

Toll Restriction Table 5																
Table Type: Allow _____ Deny _____																
Entry	Entry Number (16 Digits Maximum)															
	1	2	3	4	5	6	7	8	9	10	11	12	13	14	15	16
1																
2																
3																
4																
Table Assignment:																
Lines	_____ Stations _____															

Toll Restriction Table 2																
Table Type: Allow <i>X</i> Deny _____																
Entry	Entry Number (16 Digits Maximum)															
	1	2	3	4	5	6	7	8	9	10	11	12	13	14	15	16
1	1	8	0	0												
2	9	1	1													
3																
4																
Table Assignment:																
Lines	ALL Stations _____															

Toll Restriction Table 6																
Table Type: Allow _____ Deny _____																
Entry	Entry Number (16 Digits Maximum)															
	1	2	3	4	5	6	7	8	9	10	11	12	13	14	15	16
1																
2																
3																
4																
Table Assignment:																
Lines	_____ Stations _____															

Toll Restriction Table 3																
Table Type: Allow _____ Deny _____																
Entry	Entry Number (16 Digits Maximum)															
	1	2	3	4	5	6	7	8	9	10	11	12	13	14	15	16
1																
2																
3																
4																
Table Assignment:																
Lines	_____ Stations _____															

Toll Restriction Table 7																
Table Type: Allow _____ Deny _____																
Entry	Entry Number (16 Digits Maximum)															
	1	2	3	4	5	6	7	8	9	10	11	12	13	14	15	16
1																
2																
3																
4																
Table Assignment:																
Lines	_____ Stations _____															

Toll Restriction Table 4																
Table Type: Allow _____ Deny _____																
Entry	Entry Number (16 Digits Maximum)															
	1	2	3	4	5	6	7	8	9	10	11	12	13	14	15	16
1																
2																
3																
4																

Toll Restriction Table 8																
Table Type: Allow _____ Deny _____																
Entry	Entry Number (16 Digits Maximum)															
	1	2	3	4	5	6	7	8	9	10	11	12	13	14	15	16
1																
2																
3																
4																

4.13.1 Toll Restriction Tables—continued

Toll Restriction Table 9																
Table Type: Allow _____ Deny _____																
Entry	Entry Number (16 Digits Maximum)															
	1	2	3	4	5	6	7	8	9	10	11	12	13	14	15	16
1																
2																
3																
4																
Table Assignment: Lines _____ Stations _____																

Toll Restriction Table 13																
Table Type: Allow _____ Deny _____																
Entry	Entry Number (16 Digits Maximum)															
	1	2	3	4	5	6	7	8	9	10	11	12	13	14	15	16
1																
2																
3																
4																
Table Assignment: Lines _____ Stations _____																

Toll Restriction Table 10																
Table Type: Allow _____ Deny _____																
Entry	Entry Number (16 Digits Maximum)															
	1	2	3	4	5	6	7	8	9	10	11	12	13	14	15	16
1																
2																
3																
4																
Table Assignment: Lines _____ Stations _____																

Toll Restriction Table 14																
Table Type: Allow _____ Deny _____																
Entry	Entry Number (16 Digits Maximum)															
	1	2	3	4	5	6	7	8	9	10	11	12	13	14	15	16
1																
2																
3																
4																
Table Assignment: Lines _____ Stations _____																

Toll Restriction Table 11																
Table Type: Allow _____ Deny _____																
Entry	Entry Number (16 Digits Maximum)															
	1	2	3	4	5	6	7	8	9	10	11	12	13	14	15	16
1																
2																
3																
4																
Table Assignment: Lines _____ Stations _____																

Toll Restriction Table 15																
Table Type: Allow _____ Deny _____																
Entry	Entry Number (16 Digits Maximum)															
	1	2	3	4	5	6	7	8	9	10	11	12	13	14	15	16
1																
2																
3																
4																
Table Assignment: Lines _____ Stations _____																

Toll Restriction Table 12																
Table Type: Allow _____ Deny _____																
Entry	Entry Number (16 Digits Maximum)															
	1	2	3	4	5	6	7	8	9	10	11	12	13	14	15	16
1																
2																
3																
4																

Toll Restriction Table 16																
Table Type: Allow _____ Deny _____																
Entry	Entry Number (16 Digits Maximum)															
	1	2	3	4	5	6	7	8	9	10	11	12	13	14	15	16
1																
2																
3																
4																

4.13.2 Toll Restriction Tables—Line Assignments

Assign Toll Restriction Tables To Lines			
Port	Tables	Port	Tables
1		13	
2		14	
3		15	
4		16	
5		17	
6		18	
7		19	
8		20	
9		21	
10		22	
11		23	
12		24	

Default = All Tables Assigned To All Ports

4.13.3 Toll Restriction Assignments

Station Port	Toll Table Assignments			
	Normal Calls	Night Transfer Calls	Speed Dial Calls	Override Code
10				
11				
12				
13				
14				
15				
16				
17				
18				
19				
20				
21				
22				
23				
24				
25				
26				
27				
28				
29				
30				
31				
32				
33				
34				
35				
36				
37				
38				
39				
40				
41				
42				
43				
44				
45				
46				
47				
48				
49				
50				
51				
52				
53				
54				
55				
56				
57				
<i>Default = None Assigned</i>				

4.14 Caller ID Service Support Configuration Chart

Caller ID Lines (list 1-24 for lines)	
<i>Default = None Assigned</i>	

Caller ID Stations (list 10-57 for stations)	
<i>Default = None Assigned</i>	

Audible First Ring	Enable	Disable	
<i>Default = Disabled</i>			

SAVE Button Stations (list 10-57 for stations)	
<i>Default = None Assigned</i>	

Caller ID Distribution To COM 2	Enable	Disable	
<i>Default = Disabled</i>			

COM 2 Configuration			
Baud Rate	9600	Other (see system configuration record)	
Data Bits	8 Data/1 Stop	7 Data/2 Stop	
<i>Default = 9600 Baud, 8 Data Bits, 1 Stop Bit</i>			

4.15 Tracker Paging System Records

Tracker Paging System			
Enabled		Disabled	
<i>Default = Disabled</i>			

Tracker Pager Station Assignments					
Station Port	Enabled	Station Port	Enabled	Station Port	Enabled
10		26		42	
11		27		43	
12		28		44	
13		29		45	
14		30		46	
15		31		47	
16		32		48	
17		33		49	
18		34		50	
19		35		51	
20		36		52	
21		37		53	
22		38		54	
23		39		55	
24		40		56	
25		41		57	
<i>Default = Disabled</i>					

4.16 Digital Voice Announcing Records

Enable/Disable DVA Operation

Feature	Enabled	Disabled
DVA Support for DCD		
DVA Support for DISD		
<i>Default = Disabled</i>		

DCD Department Transfers Before Disconnect

DCD Department Transfers Before Disconnect	1	2	3	4	5	6	7	8	9	Never Disconnect
<i>Default = Never Disconnect</i>										

Inhibit DISD Digit Dialing—During Night Transfer (of Ringing) Operation

DISD Digit Dialing During Night Transfer (of Ringing) Operation	Enabled (Dialing On)	Disabled (Dialing Off)
<i>Default = Enabled</i>		

DISD Dial Time Limit

DISD Dial Time Limit	6 sec.	9 sec.	12 sec.	15 sec.	20 sec.	30 sec.	40 sec.	60 sec.	90 sec.	0 sec.
<i>Default = 12 sec.</i>										

DVA Messages (Copy this blank sheet for a record of each DVA.)

Message Type	DCD Message	DISD Message
Day Answer Message (Message 1)		
Night Answer Message (Message 2)		
Recall Message (Message 3)		
Drop Message (Message 4)		

DVA Station Ports

Station Port	DVA Assigned	Station Port	DVA Assigned
10		34	
11		35	
12		36	
13		37	
14		38	
15		39	
16		40	
17		41	
18		42	
19		43	
20		44	
21		45	
22		46	
23		47	
24		48	
25		49	
26		50	
27		51	
28		52	
29		53	
30		54	
31		55	
32		56	
33		57	
<i>Default = None Assigned</i>			

4.17 Data Interface Unit Records

Station	DIU Location	Security Group	Station	DIU Location	Security Group
10			34		
11			35		
12			36		
13			37		
14			38		
15			39		
16			40		
17			41		
18			42		
19			43		
20			44		
21			45		
22			46		
23			47		
24			48		
25			49		
26			50		
27			51		
28			52		
29			53		
30			54		
31			55		
32			56		
33			57		

Defaults = No DIUs assigned. Security groups = 0 (no assignments).

Example: The following entries show that station 12 has been programmed so that the data button (labeled "DATA") on the digital telephone at station 12 will activate the DIU connected at station 29. Also, this example shows that station 29 is assigned to security group 2.

12	29	—			
29	29	2			

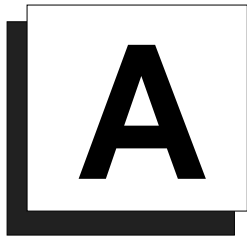

Appendix A: Understanding The System Features

A

Abandoned Hold Release

If an on-hold party hangs up at the CO/PBX end of a connection, causing an interruption in the line current, the system will drop the line from the hold condition and return it to service. The time interval between hang-up and line-drop is programmable in line class of service programming with choices of either 50 msec or 350 msec. This feature is usually dependent upon special arrangements that must be made at the CO end of the connection. The line select indicator will turn off to indicate an idle line after a call on that line has been abandoned.

See also, *Hold*.

Access Denied

The system programmer can deny access to particular lines at certain stations in the system. A station user cannot select a denied line for use. This feature is programmable on a per line/per station basis in station class of service programming.

See also, *Line Features*.

Account Codes (With Forced Positive Verification)

System users can employ account codes to identify calls by category or by any other desired grouping so that the system can print reports. The account code entry can be voluntary or the programmer can arrange the system so that the users are forced to enter an account code before they can make an outgoing call. The system compares the account code entered by a station user with a list of programmed account entries.

The programmer must program the system so that it verifies an entered account code as valid. If he or she enables verification and the system cannot match an account code that a user has dialed with the programmed account code entries, the system will sound an error tone if account code

entry is voluntary, or it will prevent the user from further dialing until he or she enters a matching account code if account code entry is forced.

A user must enter an account code either before dialing an outgoing call or after the distant party on an incoming call has hung up. Additionally, users may enter an account code before they select a line for an outgoing call if they wish. When they enter an account code without a line selection, the code will apply to any line they subsequently select at that station. On incoming and outgoing calls, the user who enters the account code is associated with the call record except when the call is transferred. On transferred calls, the transferee is associated with the call record.

As a feature to LCD speakerphone users, the programmer can arrange for a message to appear in the telephone's display to prompt the user to enter an account code during incoming or before outgoing calls. He or she can also assign the length of time that the display appears. The user must enter account code digits after the message appears. If the programmer has set the system to verify code entry, it then makes a verification attempt. If the system cannot verify the account code it causes the display to show an error message. The user may then re-enter the account code at this point. If the verification attempt is successful (or if the system does not require that the code be verified), the display will return to its normal date and time message. If the account codes are forced and the call is outgoing, then the line is dropped at the end of the display time if the user has not entered a valid account code. The programmable range for the display time is 1 to 20 seconds. When the feature is not enabled, the system inhibits the display prompt.

When a station user activates the last number redial or automatic redial features for outgoing calls, the system will automatically re-use the last account code the user entered at that station unless he or she enters a new one before activating the redial feature.

In addition to turning on the account code feature, enabling its verification, and making it either voluntary or forced, the programmer must set the account code length, specify the number of digits that the system will verify, and make up the entire list of account codes that the users will use. Account code length defines the number of digits that a user must enter before the system will accept the code. The length can range from three to 16 digits

but cannot be lower than the verified account code length. The verified account code length defines the number of digits that the system will verify before it accepts an account code as valid. As well, verified account code length defines the number of valid account codes that a programmer can store (as shown in the following table). A programmer should be aware that when he or she changes the verified account code length, the system automatically empties the list of valid account codes.

Account Code Length And Valid Account Codes

Digits Verified	Number of Valid Account Codes
3	1000
4	400
5, 6	266
7, 8	200
9, 10	160
11, 12	133
13, 14	114
15, 16	100

Even though a programmer has arranged a system to force users to enter account codes before making calls, they can always dial certain programmer-defined emergency numbers without an accompanying account code entry. The system allows a maximum of 10 programmable emergency numbers. The minimum length of an emergency number is 1 digit and the maximum length is 12 digits. Users may dial emergency numbers manually, through system speed dial, personal speed dial, last-number redial, or automatic redial—with or without account code entry.

Forced Account Code Entry For CENTREX Users

The programmer may set the TAP time so that CENTREX users *do not* have to re-enter an account code after pressing the TAP button. The programmer may also set the system so that non-CENTREX users *do* have to enter an account code after pressing TAP.

- If the TAP time is set for 1 second or less (the hookflash time), the system will not clear an account code after a TAP entry. This enables CENTREX users to do host system transfers without entering an account code a second time.
- If the programmer sets the TAP time for 1.5 seconds or more (the recall time), the system clears the account code after TAP entry. This forces non-CENTREX users to re-enter an account code if they press TAP to recall a new dial tone.

Account Code Button

A programmer can use station class of service programming to assign an account code button to any programmable button location at a station as part of the button mapping procedure. With this account code button available, the user can press it and then dial an account code without interrupting the call. Only the user of the Account Code button will hear the DTMF tones when he or she dials the code. The distant on-line party will not hear the DTMF tones, and the system will not place the line on hold. The user can hear the distant on-line party while he or she is dialing an account code. If the telephone does not provide an account code button, the user must dial an intercom code before he or she dials the account code digits.

All-Call Paging

All-call paging allows all stations to receive announcements through the station speaker at once. The system can also send all-call paging to the paging port where it applies it to the input of an external paging amplifier. Origination of announcements must be via the station handset. A programmer can arrange each station to receive and/or originate all-call page. He or she enables the ability to receive and originate all-call paging at a station through station class of service programming.

See also, *Paging*.

Analog Terminal Interface Support

The digital telephone system supports the operation of the Analog Terminal Interface (ATI-D). The ATI-D is a multipurpose on-premise accessory with dual circuits that provide an industry-standard telephone interface. This feature adapts most industry-standard (IST) devices and voice processing systems to the digital telephone system. The ATI-D accepts both tone and pulse (rotary) dialing from these devices. Each ATI-D circuit will drive a load with a maximum ringer equivalence number (REN) of 2.0 thus allowing more than one IST connection at each ATI-D circuit input. The ATI-D supports a wide variety of IST equipment such as model 500 and 2500 telephones, cordless telephones, answering machines, and FAX machines. The ATI-D is housed in a metal enclosure and is powered by the telephone system through the station port

connections. It contains a ringing generator to generate a ringing signal for the IST devices.

Area Paging Interface

Any station user can dial a special code number in response to an all-call or zone page and be connected to the paging party in a private conversation. All-call or zone paging is provided to the stations through the station class of service programming.

See also, *Paging*.

Assist Button

This feature allows a station user to program a button to be used for sending a message to an LCD speakerphone. Once programmed, the station user can press the ASSIST button at anytime to sound a tone burst at the called station and present a preprogrammed message in the station display. The user can send a message while on a call without alerting the distant party. This feature is useful for requesting assistance while engaging on a call. For example, a customer service representative could request assistance from a supervisor while talking to a problem caller. The supervisor, upon receiving the tone and noting the display message, could perform an executive override or service observing action to join the call or monitor it.

See also, *Messaging*.

Automatic Callback

If a telephone user encounters a busy tone or a ring no-answer after calling an intercom station, She or he can dial a special code number that will cause the system to automatically ring both the user's telephone and the one that he or she was calling. This automatic callback occurs after the busy station becomes idle or after the user at the ring no-answer station takes some action at it that indicates to the system that it is available to be answered. No class of service programming is required to enable this feature.

See also, *Intercom*.

Automatic Dialing Of Stored Numbers

Automatic Dialing

The system supports up to 24 automatic dial (autodial) numbers per station. Autodial buttons can store up to 16 digits plus an intercom or line selection. Stored digits include 0-9, *, and #. The system stores a pause at any point where the HOLD button is pressed, and stores a hookflash at any point where the TAP button is pressed. Automatic dialing provides a way to obtain one-button access to frequently used system features. This feature does not require any class of service to enable it.

Programmable DSS/BLF

A station user can store one-button, direct station selection (DSS) at any memory button location to create a DSS memory button. When this button is pressed, any active outside call is automatically placed on hold and an intercom call is automatically made to that previously stored station number. The visual indicators of the stations programmed at the button locations form a busy lamp field (BLF). The BLF conveys station status to the user. An autodial number can also be programmed as a secondary function at every DSS/BLF memory location. No class of service is required.

Station Speed Dial

Each station provides 10 speed dial number locations at the keypad buttons. Station speed dial numbers can be up to 16 digits in length and can include line or intercom selection, numbers, #, *, pauses, and hookflash signals. A user can store a pause by pressing the HOLD button and store a hookflash signal by pressing the TAP button.

System Speed Dial

The system provides 99 system-wide speed dial numbers. The system speed dial numbers can be up to thirty-two digits in length, and can include numbers, #, *, pauses, and hookflash signals. The attendant programs the system speed dial numbers and names at station 10 or 12 for use at every station in the system. No class of service programming is required.

Automatic Hold For Intercom

If a user selects the second intercom line while a call is active on the first intercom line, this automatic hold feature lets the system automatically place the first intercom call on hold. Use station class of service programming to enable this feature.

See also, *Hold*.

Automatic Hold—Transfer To Line

A programmer can use class of service programming to make this system feature available to selected stations. When enabled, a user can press any line button and cause an active line to automatically go on hold. This feature allows a user to move from line to line without having to press the HOLD button to place any current calls on hold. Use station class of service programming to enable this feature at the desired stations.

See also, *Hold*.

Automatic Pause Insertion

When the system stores a dialed number for later redial, it automatically stores a pause whenever the user waits between digits for at least two seconds. The system inserts the automatic pause in the stored number sequence at the point where the manual pause in dialing occurred. The length of the automatic pause is programmable.

See also, *Automatic Dialing of Stored Numbers* and *Redialing*.

Automatic Redial (Of Busy Number Or Unanswered Call)

A user can automatically redial a busy number or unanswered call by activating this feature. Once the user activates automatic redial, the station will select the line, automatically dial the number, and wait for a response. It will do this once a minute for approximately 10 minutes unless the user deactivates the feature by pressing that button or another button or by lifting the handset. The feature cycle is timed and does not have busy detection circuitry. Because of this, if the user is operating handsfree when the called party answers, she or he must lift the handset to prevent the caller from being cut off by the timing cycle. The automatic redial button is a designated programmable button position and the user must program its location to make it active.

See also, *Redialing*.

Automatic Station Relocation

With this feature, the system will automatically recognize a particular station should that station be relocated to a new station port. When someone places a telephone at a new port location, it will continue to provide the same class of service parameters and respond to the same extension numbers as it did at the original station port. A programmer must enable this system feature using system class of service programming. As an added feature when someone plugs an LCD speakerphone in a new station port, the system will prompt the user on the display to verify the relocation of features.

Auxiliary Equipment Interface

An installer can use the auxiliary equipment interface to connect a telephone device or a data device to an outside line ahead of the common equipment. The system can detect an off-hook condition in a device that an installer has connected to the auxiliary equipment interface, and turn on the status light for that line at telephones that have that line appearance. It does this to indicate that the line is busy and not available for station use. Auxiliary equipment interface connections provide connections to lines 2 and 4. A user cannot interrupt an external device by pressing the line button unless the line has been programmed to be non-private.

Auxiliary Ringer Interface

The auxiliary ringer interface provides “dry-contact” relay closures which track the ringing pattern whenever the system sends ringing to a programmable destination. Programmers can program relay control to be activated when the system sends ringing to station port 17 or to the paging port.

When programmed for station port 17 ringing, an installer often uses an external device to provide loud ringing. When programmed for paging port ringing, an installer often installs an external paging amplifier to sound the rings. The system supplies ringing tones to the paging port along with the relay closures. It can send the ringing tones to the input of an external paging amplifier and the installer can arrange the wiring so that the relay closures energize the paging amplifier while it is receiving the ringing tone. Use system class of service programming to choose either the paging port or station port 17 for the ringing port relay control. Also use system class of service to determine the type of ringing sent to the paging port. Use station class of service programming to determine the type of ringing that the system sends to station port 17.

Programmers can arrange for the system to send ringing tones for particular lines through the PA port. They can choose between intercom tone and DTMF signaling tone for the PA port ringing. They should choose the intercom tone if they desire a soft tone and the DTMF tone if they desire a loud tone.

See also, *Ringing*.

B

Background Music

If the installer connects a customer-provided external music source to the system, the music from that source will sound through the station loudspeakers after the users turn it on at their stations. They can adjust the loudness of this background music with the loudspeaker volume control. The system automatically turns the background music off during calls. This feature requires no class of service programming.

See also, *Music Features*.

Basic Key Service (1A2) Emulation

The system provides all of the basic, 1A2-type, key service features. These features are: selective line pickup, common line pickup, multiline pickup, and hold. No special class of service programming is required.

Battery Back-Up

Battery Back-Up (Chassis, Cable, And Batteries)

The manufacturer offers battery back-up assemblies including chassis, cable, fuses, and batteries as optional kits available through normal distribution channels. The assemblies are designed so that installers can connect them directly to the uninterruptable power source (UPS) interface located on the common equipment chassis. The system does not require any action from the telephone user to make it operate on battery power nor does it require any class of service programming action on the programmer's part.

Battery Back-Up Interface

The common equipment cabinet provides an interface for an optional battery back-up kit to give full uninterrupted system power in case of an AC power loss. The switching and charge circuitry are in the common equipment, while the batteries, chassis, and cable are packaged as a separate option. When plugged into an active AC power source the common equipment will constantly charge the attached batteries. Built-in circuitry automatically switches to battery power when AC power is lost. With batteries at full charge, a fully loaded system will operate for a minimum of one hour without AC power.

Block Programming

A programmer can assign a particular line or station's class of service to an entire block of lines or stations with one programming action. This feature eliminates the need for him or her to individually program stations and lines with the same class of service. A programmer can perform a block programming class of service after he or she has programmed a station class of service or line class of service for a particular station or line.

See also, *Class Of Service*.

C

Call Announce With Handsfree Answerback

The internal loudspeaker at each station provides call-announce capability over the intercom link. A user can make a handsfree response to a call-announce call without lifting the handset.

The user can use the MUTE button to block all handsfree answerback response. This arrangement will prevent a station user from monitoring another station site using the monitoring ability of the voice announce feature. When a user presses the MUTE button, all handsfree answerback is disabled, inhibiting any off-site monitoring. The MUTE light turns on to indicate that this feature is active.

See also, *Intercom*.

Call Costing And Station Message Detail Accounting Reports

The system provides built-in, estimated costing of all outside calls. It also provides station message detail accounting (SMDA) printout reports of all costed calls and displays call costs on LCD speakerphones.

Call costing, in general, provides a means of establishing costs to be applied to outside calls made from system telephones. Call costing computes charges for a call after it is completed. It does not restrict dialing as toll restriction does. Call costs are based on a two-tier time rate and includes a line surcharge cost. A programmer can program allowances for call set-up and minimum call duration. The system provides several ways of determining call costing, making it possible to apply reasonable rates for the entire country.

The system will automatically provide a report whenever the costed call storage reaches 95 percent of capacity. Additionally, the programmer can arrange for these reports to be printed automatically at a specific time of day.

The system can produce five different SMDA records:

- Detailed report sorted by stations,
- Detailed report sorted by account codes,
- Line summary report,
- Department summary report,
- Department Call Distribution (DCD),
- A general output of all records.

Upon completion of report printing, the telephone attendant can delete all records the system used for the reports. The system will not delete any call records created between the time the report printout was started and completed. If the attendant does not delete the reports after they are printed, a later command to delete records will delete all records at that point and not just the ones that were printed in the previously generated reports. The programmer can take programming action to always delete the records after they have been printed. The attendant has the ability to request particular reports to be printed at any time they are required.

The programmer can establish account codes to allow system users to identify calls by category or by any other desired grouping so that the system can report costing by that category or grouping. Further, the programmer can define department numbers and assign stations to different departments so that the system can produce call cost reports on a department-by-department basis.

Programmers must use call costing and SMDA reporting class of service programming to set the costing features, and assign stations to specific SMDA departments using the station class of service programming. He or she can also enable the LCD speakerphone display of costed calls through station class of service programming.

SMDA Reporting Through VDT Programming and Per-Station SMDA

The programmer can use the VDT programming option to request that the system send SMDA reports to either data port A or data port B for printout. It is also possible to use this feature remotely through a data communications arrangement to capture SMDA reports. In addition, the system provides SMDA station reports for individual stations when the attendant requests them by dialing certain code numbers at station 10 or 12. Note, however, that the system can provide only one station report at a time.

Station Message Detail Recording (SMDR)

The SMDR feature generates a call record for printing as soon as the system collects the record. It presents the call record at an RS-232 level as ASCII transmit data in an 80-column format at the data port available for that purpose.

Call Forwarding

Call Forwarding On All Calls

This feature allows a station user to designate another station or the attendant station as the recipient of all calls normally directed to ring at his or her station. If the user has call forwarding enabled when the attendant activates night transfer of ringing, the system forwards the night ringing assignment of the user's station. Calls that the system forwards to a recipient station can be forwarded again by that station user to another station. Thus, two levels of call forwarding on all calls can occur, first, from station A to station B and then, from station B to station C. As a reminder that call forwarding is enabled, a short tone burst will occur at the user's station for each intercom call that it receives while its calls are forwarded.

When the programmer has assigned a call forward button to a station, its associated LED will turn on to indicate that the feature is enabled when the user presses it; however, if the call forward button is programmed as a second level to a DSS/BLF button, the system reserves the LED indication for BLF indication. On LCD speakerphones that are recipients of call forwarding, the display will indicate the extension number or station name for the station from which an intercom call was forwarded.

Call Forwarding—Personal

Call forwarding of personal calls allows a station user to designate another station number (or the attendant station number) to be the recipient of intercom and prime line calls normally directed to that user's station. For each intercom call received while call forward is enabled, a ring reminder (short tone burst) will be sounded at the forwarding station to remind the user that his or her calls are being forwarded. On LCD speakerphones that are recipients of call forwarding, the display will indicate the extension number or station name for the station from which an intercom call was forwarded.

Call Forwarding of Ring No-Answer (RNA) and/or Busy Calls

With this call forwarding enhancement, the system can forward both the RNA and the busy calls that a station receives or forward just the RNA or just the busy calls that the station receives. Being able to separate these call forwarding schemes allows users to have forwarding just for the calls that ring their stations when they are away from their telephones but not burden their hunt-linked fellows with calls they receive while they are busy on existing calls.

A RNA call first rings for a programmed number of times at the receiving station then start ringing at the station that is hunt-linked to the receiving station. If that hunt-linked station is also hunt-linked to another station, the call will follow that link. A call to a busy station will immediately start ringing at the station that is hunt-linked to the busy station. If that hunt-linked station is also hunt-linked to another station, the call will follow that link.

To enable this feature enhancement, programmers must first enable tone first signalling and arrange an intercom hunt group. Then, they can individually enable call forwarding for RNA calls and call forwarding for busy calls. They can turn on either call forwarding scheme alone or turn on both schemes as the site demands dictate.

Ring-No-Answer Forwarding Of Transferred Calls

This feature enhances the existing automatic RNA call forwarding feature to include forwarding of transferred lines to individual stations. When a telephone user transfers a line to a station, the call will ring at the station receiving the transfer for the programmed number of rings. After that, the call will start ringing at the station that is hunt-linked to the station first receiving the transfer. If that station is also hunt-linked to another station, the call will follow that link. When the transfer recall time expires, the call will recall back to the station that initiated the transfer. The hunt link can be a circular one. The transferred line will circle the hunt link until it recalls. Alternately, the station can be hunt-linked to voice mail so that a transferred call will forward to the station's voice mail box if it is unanswered. For this feature to work properly, the following details must be considered:

- you must hunt-link the station receiving a transfer to another station;
- you must program the number of rings to occur before forwarding;
- you must insure that the transfer recall time is larger than the total time of RNA to all hunt linked stations (if it is not, the transferred call will recall before the call gets to the end of the hunt link).

For an example of this last consideration, assume station 12 is hunt-linked to station 13 which is also hunt-linked to station 14. Further assume that station 12 and 13 have their RNA's set to two rings. A call that is transferred to station 12 will ring there twice, then it will ring at station 13 twice, then it will ring station 14 until transfer recall time expires. Each transfer ring cycle is approximately four seconds; therefore, the line will ring the station for approximately eight seconds before it moves to the next station. Since there are three stations linked together, this event will require 24 seconds. This means that you should set the transfer recall time for 25 seconds or higher.

You can use this formula to determine minimum transfer recall time:

If:

4 = transfer ring cycle time in seconds

R = how many RNA rings assigned per station

S = how many stations are in hunt list

Then:

$4 \times R \times S = \text{minimum transfer recall time}$

Call Park

The call park feature is similar to a manual hold condition. A user can park a call a particular station and retrieve it at any station in the system by dialing the appropriate access code.

NOTE: The retrieving station must have access to the line on which the call appears.

Calls are parked and retrieved within the system through the use of dialing codes. The system provides nine parking circuits (orbits). Call park, when used with the paging features, allows a system attendant to direct calls to roving personnel. A call that is left in a parking orbit for preprogrammed length of time automatically returns to a timed hold recall condition at the station where the user originally parked the call.

See also, *Hold*.

Call Pickup

Directed Call Pickup

A station user can dial a code, followed by the extension number of a ringing station, to answer the ringing call.

Group Call Pickup

If a call rings to any station in a pre-programmed group and another user in the group wishes to answer the call, that user may dial the group pickup code and answer the call. Four different groups can exist with any number of stations in a group. Overlap is provided by allowing stations to be in more than one group thus enabling those stations to pick up for stations in more than one group. The programmer must place the system stations in logical answering groups by group them together using the station class of service programming.

Call Transfer

Screened Call Transfer

Screened call transfer allows station users to transfer outside calls from one station to another, via the intercom link, in one of two ways. If both stations have access to the line, a user effects a common line pickup transfer. If the other station does not have access to the incoming line, the user uses the transfer/conference button to effect the transfer. For a screened transfer, the transferring user precedes the transfer with an announcement to the party that is to receive the transferred call.

Unanswered Call Transfer Recall Timing

A transferred call that is unanswered after a pre-programmed length of time will return to the station that transferred it. The system will return the call to both attendant stations when the tandem attendant feature is enabled. When LCD speakerphones are employed, the display will show the station number or name as well as the line number that is being re-called. The system class of service programming determines the recall time for an unanswered call transfer.

Unscreened Call Transfer

A user can transfer a call to another station without first announcing it. The transferred call will camp-on to the other station where it will ring and await an answer. The call will automatically ring back to the transferring station after a programmable recall period. There is no limit as to how many calls users can camp-on to another station. A transferred call will only ring if the station is idle. If the station is busy, the call will wait until it is idle before it rings. The programmer can use the system class of service programming to set the recall time for an unanswered transferred call.

Call Waiting Tone

A telephone user can signal a busy station with the call waiting tone to indicate that he or she wishes to contact them. Users dial a special code to activate the call waiting tone.

Caller ID

The central office sends Caller ID data along lines assigned to the Caller ID service. Caller ID information is displayed at a system LCD speakerphone only if the programmer assigns that telephone to the Caller ID service, and then only for those Caller ID lines that are assigned to that station and arranged to perform as follows:

- ring audibly
- can be answered by user pressing button for the ringing line
- are transferred to the station.

The station receives Caller ID data between the first and second rings. A programmer can enable the first ring for a line assigned to Caller ID to be either audible or silent. Selecting the “silent” option ensures that the Caller ID data is displayed prior to ringing, nearly eliminating the loss of Caller ID data.

Station users may automatically retrieve and dial the last Caller ID number displayed at a station by using a preprogrammed SAVE recovery button. Because the programmer can store the local area code and up to 100 6-digit area code and local office codes, ten-digit Caller ID numbers can automatically be transformed into a format that can be dialed.

(seven-, eight-, and eleven-digit Caller ID numbers are already in a format that can be dialed and do not need to be transformed.)

The system will dial those numbers that are present in the 6-digit table as local calls even if they are in different area codes.

All Caller ID features require that the Caller ID decoder device (product code CID08) deliver Caller ID data to the system's RS-232 data port B. The programmer must configure this port to match the output of the Caller ID decoder device. The recommended configuration is 9600 baud, with eight data bits and one stop bit. The programmer must use VDT programming to do this.

Caller ID distribution is in the form of messages which specify the Caller ID data for lines with incoming calls, and identify the stations answering such lines. The data is in the ASCII format and is suitable for use with PC-based application programs.

Calling Station Identification On BLF

If a user has stored the station number of a calling station into the direct station select/busy lamp field (DSS/BLF) of his or her station, the flashing of the corresponding BLF light will identify the caller. The BLF lights also indicate the status of the DSS telephone using the department pilot number.

Class Of Service

Block Programming

A programmer can assign a particular line or station's class of service to an entire block of lines or stations with one programming action. This feature eliminates the need for him or her to individually program stations and lines with the same class of service. A programmer can perform a block programming class of service after he or she has programmed a station class of service or line class of service for a particular station or line.

Class Of Service Programming (From Main Station)

Class of service (COS) programming is used by the installer/programmer to configure and assign all system, line, station, and special purpose operating features. The installer/programmer enters COS programming by dialing an access code over the intercom line. System administrators can enter COS programming with another code to reprogram any system, station, or special purpose operating feature that may require change at a later date. Line reprogramming ability is not available through system administration programming. The system attendant can reprogram certain system-wide

features that require periodic change by entering COS programming with another code provided for this purpose. The station user can program individual stations for speed dial, autodial and direct station selection (DSS) by entering COS with a code provided for that purpose. Thus, COS programming is arranged with a hierarchical order from the highest (the installer/programmer) to the lowest (the station user) level with a higher level programmer having the ability to do anything a lower level programmer can do without exiting a current programming mode. However, only the station user can program the speed dial and autodial locations at a telephone.

All class of service (COS) programming is performed from station 10 or 12. Any station and console combination will function in this mode and provide visual feedback with the LED associated with the programming button. By employing an LCD speakerphone, however, the programmer will have the benefit of display prompts and verifications to simplify and clarify the programming procedures.

Flexible Station And Line Class Of Service Control

The extension number of a station and all other programmable attributes that are initially assigned to a particular station port and the line, along with all programmable line attributes that are initially connected to a particular line port can be re-assigned to a different port through programming action. This feature allows adds, moves, and changes without re-locating the station and line wiring. A programmer can use line and station class of service programming are used to reassign stations and lines.

Class Of Service Programming (From Video Display Terminal)

A programmer can use an asynchronous, serial data terminal with an RS-232 interface to effect class of service programming through menu-driven procedures. For more information on VDT programming, see section 3.2.2

Class Of Service Program Printout

The common equipment provides serial data ports that the installer can use to interface an RS-232 compatible, asynchronous serial data printer to the system. The connected printer will provide a printout of class of service and toll restriction records. The programmer can use the data printer service class of service programming procedure to specify the nature and extent of each requested printout. He or she can use the system class of service programming to specify the bit-length and baud rate of the data.

Default Functional Program

At initial power-up, the system sets the operating features to a specific group of operating conditions (default conditions). The default conditions provide a complete operating system for normal use. The installer can leave the system defaulted or reprogram as

desired. After a programmer has reprogrammed a system, he or she can re-default it by using the system, line, and station class of service programming or use a master clear to default the entire system and erase all stored programmable button information.

Remote Programming And Administration

Both remote class of service programming and the transmission of SMDR data for printing are available through serial data ports. The system supports X-on X-off terminal control codes as well as a DTR signal for handshaking. The system data communications operates per the popular XMODEM protocol. The database can be uploaded or downloaded, error free, from or to a remote computer that is running software that supports the XMODEM protocol. The two serial data ports allow VDT programming (either local or remote) to be conducted through one port at the same time that the other port is being used to send SMDR data for printing. VDT programming of the system is menu driven.

Common Audible Ringer Interface

Connections are available at the common equipment that provides “dry-contact” relay closures whenever an incoming line rings. These contact closures track the ringing pattern and can be used to control an external signaling device.

See also, *Ringling*.

Conferencing

Add-On Conferencing

With this feature, a user at a station that is operating in a private mode can add up to three other stations to an outside call.

Multiline Conferencing

This feature will allow one station to access up to four outside lines at the same time resulting in a conference arrangement. The user employs the transfer/conference button to effect the conference.

Unsupervised Conferencing

After a user has established a conference between an internal party and a maximum of two external parties, this feature allows the internal party to drop out of the conference by dialing a special code. The conference between the two outside parties continues in an unsupervised condition.

Console Support

The digital telephone system supports the installation and use of a DSS/BLF console at any available station port. The number of installed consoles is limited only by port availability; however, since a console complements a companion telephone located in an adjacent station port, the installer can use up to one-half of the available station ports for consoles. In addition with the dual console feature (discussed later), a full two-thirds of the total station port capacity is available for console use.

The installer can assign two consoles (usually two 32-button consoles) to one telephone using one station port each. This feature is especially useful when used with a G1632 system that has one or two GM408 expansion modules included with it. The installer can place the first console at the station port that is logic-paired with the station that he or she wishes to complement. The installer can put the second console at any station port except 10 or 11 and use class of service programming to assign it to the station port that is logic-paired with the first console.

The installer can put a console at any station port and assign it to a station without first installing a console at the station's logic-paired port. This configuration is convenient for adding a console to an existing telephone installation that already has its logic-paired port occupied; however, one must not use this configuration for assigning a console to station ports 10 and 12 because the console buttons will not be usable for programming.

As discussed above, this feature is also useful for adding a second console to a station that already has a paired console installed with it.

The digital telephone system automatically recognizes a console when it is connected to a station port and automatically assigns station intercom numbers to the console buttons for direct station selection (DSS) purposes with associated busy lamp field (BLF) status lights. However, the console buttons are fully programmable and the station user can customize them as he or she sees fit by programming them as DSS buttons or as automatic dialing (autodial) buttons. When the user programs the buttons for DSS use, autodial capability is also available at a secondary level at each DSS button. The first 48 buttons on a 64-button console are programmable for DSS and/or autodial use.

While the first console (the one installed at the logic-paired port) extends the autodial buttons of the paired telephone by 48 and provides DSS/BLF coverage for station ports 10 through 57, the second console (the one installed at the programmed station port) provides DSS/BLF coverage as follows:

- On a 32-station system with two 8-station expansion modules, the first 16 buttons are automatically assigned (defaulted) to station ports 42 through 57 for DSS purposes.
- On a 32-station system with one 8-station expansion module, the first 8 buttons are automatically assigned (defaulted) to station ports 42 through 49 for DSS purposes.
- On any other smaller station capacity system, all buttons are unassigned.

When an installer installs a console and programs it to complement a telephone without first having a console installed at a port that is logic-paired to that telephone, its button assignment is automatically defaulted, as described above, but the user can reprogram it as required. It is important to remember that when a programmer programs for a second console, the system sets the console button mapping to that which is described above. When a programmer clear the assignment, the system resets the button mapping to match a logic-paired console. This means that when the second console feature is cleared, the console installed at that port complements the telephone that is installed at its logic-paired port instead of the telephone that is located at the program designated port, and its buttons are automatically reassigned to stations 10 through 57.

D

Data Interface Unit

The Data Interface Unit (DIU) is a device that provides the capability to plug an Industry Standard Telephone (IST) or another device (such as a FAX machine or modem) into the digital station port of a Digital Service Unit (DSU).

The DIU functions as a switch that connects the DSU station voice channel to either the digital proprietary phone port (connector labeled “PHONE”) or the IST port (connector labeled “FAX/MODEM”). The IST port can be used to provide a data connection for a FAX or modem. It can also be used for virtually any IST device such as a cordless telephone or answering machine.

In addition to the power connector, the DIU has a connector for a digital multiline telephone (*Impact* or *DigiTech*), and another connector that you can use for any one of the following on-premise devices:

- Industry Standard Telephone (IST)
- facsimile machine (FAX), or
- modem.

The user controls the DIU by pressing a preprogrammed DATA button on his/her digital telephone. The installer can also program a DATA button on a remote telephone that can control the DIU as well. The DATA LED on the digital telephone provides the user with visual feedback on DIU status.

The system administrator can program up to three security groups and assign them to work groups. This safeguards stored data on IST devices such as personal computers by denying access to users from outside the group. For example, if a caller in security group 1 calls a station in security group 2, and the IST device on the DIU at the called station is selected, the caller will hear a busy tone. When the multiline telephone on the DIU is selected instead, the caller can make a station to station call in the normal manner.

The DIU will operate reliably at baud rates up to 9600 (outside calls) and 14400 (intercom calls).

Data Security

This data security feature will prevent any type of tone (DTMF, camp-on, barge-in, etc.) from interrupting a call that is active on a port programmed with the feature. This prevents interference to non-voice communications from occurring when the port is being used as a data port (when operating a modem through an ATI-D port for, example). The programmer can use station class of service programming to enable a data security port.

Default Functional Program

At initial power-up, the system sets the operating features to a specific group of operating conditions (default conditions). The default conditions provide a complete operating system for normal use. The installer can leave the system defaulted or reprogram as desired. After a programmer has reprogrammed a system, he or she can re-default it by using the system, line, and station class of service programming or use a master clear to default the entire system and erase all stored programmable button information.

See also, *Class Of Service*.

Default Toll Restriction

The system defaults two toll restriction tables with pre-programmed values and pre-assigned to all lines. The programmer needs only to assign these tables to the stations by programming action to put them into effect. He or she can use the toll restriction table configuration class of service programming to reprogram the defaulted tables with different information as needed.

See also, *Toll Restriction*.

Delayed Ringing

Ring assignments are programmable. A station can be programmed to provide delayed ringing on some lines while providing immediate ringing on other lines. Delayed ringing is assigned to certain lines at each station through station class of service programming. When a programmer assigns delayed ringing to a station for certain lines, he or she can also assign the time length of the delay.

See also, *Ring*.

Departmental Calling Distribution (DCD) Report

Refer to the discussion titled Direct Department Calling With Departmental Call Distribution (DCD).

Designated Programmable Buttons

Designated programmable buttons are those that the programmer assigns to a station using the button mapping procedures that are a part of station class of service programming. These buttons provide one-button access to a broad range of features. While the programmer must assign most designated buttons, the station users can assign the auto redial button and the response message button themselves.

Dial 0 For System Attendant

The system attendant station (station 10) is signaled whenever anyone dials the digit 0 on the intercom line.

Dial By Name

The Dial By Name feature allows users to employ any two-line display, LCD speakerphone to search through an index of names and automatically call the located name.

By pressing the **option** button, users enter the Dial By Name menu. From that menu, they either press the **int** button for intercom calling or the **ext** button for speed dial calling, and then dial three digits for the first three letters of the name they want to locate. The system displays the first match to the dialed digits that it finds. The user can then either press the **dial** button to make the call to the displayed location or press the **next** button to display the next name in the index.

The Dial By Name feature uses the seven-character station names associated with the station ports for searching through the list of stations for intercom calling. 16-character names are used for searching through the list of system speed dial entries.

When users make a sequential search through the stored index of names, the system searches the list as it was entered. Programmers or system attendants must arrange the list in the desired sequence as they store the entries.

Digital Voice Announcing

Digital voice announcing uses a hardware peripheral device (product code DVA01) connected to a digital station port to play recorded messages during an in-progress call. The DVA stores the messages in its memory for recall when needed. The system attendant stores messages in the DVA device by delivering them from the telephone handset of station 10 or 12 or by playing the contents of a professionally-supplied tape recording into the DVA memory. When enabled by the DSU II, the DVA provides up to four messages. The total available message time is two minutes. With each DVA servicing one outside line, the system installer can add several DVAs to enable the digital telephone system to answer several lines with digital voice announcing.

While the DVA is not an automatic attendant, it enhances the following features: direct department calling with departmental calling distribution (DCD), direct inward station dialing (DISD), and Tracker Paging System. DVA enhances these features by providing automated voice prompts and dialing instruction to callers. In general, the voice prompt messages are of four categories illustrated in the following examples:

Day Answer Messages

For DCD callers—*“Welcome to Acme’s sales department, all of our agents are busy. Please stay on the line and an agent will answer your call as soon as possible.”*

For DISD callers—*“Welcome to Acme Company. If you know your party’s extension, dial it now; otherwise, stay on the line and an attendant will answer your call.”*

Night Answer Messages

For DCD callers—*“Welcome to Acme’s sales department. Our hours are eight to four-thirty. Please call tomorrow during those hours.”*

For DISD callers—*“Welcome to Acme Company. Our hours are eight to four-thirty. Please call tomorrow during those hours.”*

Recall Messages

For DCD callers—*“Please hold. An agent will be with you as soon as possible.”*

For DISD callers—*“The party you have called is not available. Please dial a new extension number.”*

For DISD callers in systems that have the Tracker Paging System installed—*“The party you have called is not available. Please dial a new extension number or dial # plus your call-back number followed by another # to page your party.”*

Drop Message

—*“Thanks for calling Acme, good-bye.”*

Typically, the DVA services a DCD call in the following manner:

1. A caller rings a department line.
2. If all department stations are busy, the DSU answers the call and triggers the DVA to play the day or night answer message. The DSU transfers the line to the department if the system is in the day mode or drops the line if it is in the night mode.
3. A transferred line recalls to the DSU after a transfer recall time, and the DVA plays a recall message to the caller. The DSU transfers the call once more to the department. This action repeats for a programmed number of times.
4. After the last recall, the DVA plays the drop message and the DSU drops the line.

Typically, the DVA services a DISD call in the following manner:

1. A caller rings a DISD line.
2. After a programmed number of rings, the DSU answers the call and triggers the DVA to play the day or night answer message.
3. The DSU decodes the digits that the caller dials and rings the station or department dialed by the caller. Should the caller dial an incorrect extension, the DSU sends an error tone and asks the caller to dial the code again.

4. A DISD line recalls to the DSU after a transfer recall time, and the DVA plays a recall message to the caller. The DSU transfers the call once more to the same or different stations. This action repeats three times.
5. After the last recall, the DVA plays the drop message and the DSU drops the line.

The installer can connect DVA devices to any available digital station ports. The availability of station ports limits the number of DVA devices that can be connected to the system. The system programmer arranges the DSU class of service programming to customize the DVA operation for specific applications.

See also, *Digital Voice Announcing*

Direct Department Calling With Departmental Call Distribution

The system enhances direct department calling with departmental call distribution (DCD) and provides a means by which outside lines can be assigned to one of four different departments. Calls received on department lines and calls that are transferred to a department from within the system search for an idle station in that department. The system distributes department calls evenly throughout the department stations for answering with individual stations having the ability to be taken out of service as necessary. The system places calls received on department lines and calls that are transferred to a department from within the system in a queue for servicing. It assigns new calls, transferred calls, and held calls a time stamp so that they will be serviced in the order of their arrival.

The system allows up to four departments and allows up to 16 stations and a minimum of 3 stations (plus one overflow station) in each one. The programmer can assign a station to more than one department, if desired. Since the programmer can assign a station to more than one department, she or he can add the attendant station to serve as the overflow station for all departments if desired. The programmer can assign separate pilot numbers (extension numbers) to each department that the users can use for making intercom calls or doing call transfers to the department.

The direct department calling feature requires that the programmer assign lines and stations to a department. It does not require that he or she assign department lines to appear at buttons on department stations. If a site requires that a particular department line must appear at a particular department station, the programmer can assign it; however, the programmer must ensure that neither direct nor delayed ringing is enabled for that line at that station.

An incoming call searches for the first station available to answer a call. If all stations in a department are busy or ring with no answer (RNA call), the call will go to the overflow station in that department (if one has been programmed). If there is no overflow station programmed, the call continues to try the department stations until it is answered or

dropped by the caller. The caller continues to receive ringback tone until the call is answered. The overflow station can service the call or transfer it back to the department using the department pilot number. When the call is transferred back to the department by an overflow station, it will not return to the overflow station until that station is idle and has no ringing calls either new or transferred. Instead, the call will camp-on at the department and wait for a station to become idle. The caller will receive music while on hold if the system is so equipped. To provide reassurance to the caller during ringing it is recommended that a music source be connected to the system. The call will remain in a held state until it is answered or until the department transfer recall timeout period has ended.

When the recall timeout period has ended, the call will return to the transferring station.

Intercom calls that are made to the department will test the department stations for busy or a RNA. If all stations are busy, a busy tone is returned to the caller. Intercom calls will not camp-on at the department but will go to the overflow station. Further, the system camp-on feature cannot be used to camp-on to a department.

Subsequent calls to a department on a particular line always try the next station in the department from whichever station serviced the last call on that line.

To understand this, assume a department with stations 15, 16, and 12 assigned as department members 1, 2, and 3. Further assume lines 1, 2, and 3 are programmed to ring in this department. To create a randomizing effect, the system tracks for each line which department member (1, 2, or 3) serviced it last. When the next call arrives on line 1, for instance, the system makes a search for the next idle department member after the last one that serviced a call on line 1. Since there are several lines assigned to the department and conversation times and wrap-up times vary, a natural random distribution of calls on lines 1, 2, and 3 at stations 15, 16, and 12 will occur. Further, since the system is keeping track on a per line basis of the servicing stations as department members instead of station numbers, the programmer could rearrange the department list without having any effect on call distribution. As the programmer adds more stations to a department, the randomizing effect improves.

Since the RNA time of a station is a programmable feature, department stations can be set to have a short RNA time to allow a call to search rapidly through a department for an answer.

When an outside or transferred call is ringing at a department station, the station user can press the pre-programmed Do Not Disturb (DND) button to place the station in an off-duty condition. While off-duty, all outside and transferred calls skip to the next department station. This off-duty condition remains set until the DND button is pressed again to place the station back in service. When the overflow station is set to DND, all incoming and transferred calls will return to the department queue.

A department station can also be taken out of service and placed in a wrap-up mode to provide the user time for doing such things as follow-up paperwork. While a station is in a wrap-up mode, all outside and transferred calls skip to the next department station. The station user sets the wrap-up mode by pressing Hold DND and presses these buttons again to clear the wrap-up mode.

It should be noted that the departments formed for use with this direct department calling feature are different from those departments used in SMDA reporting. Assign department transfer recall time (unanswered call transfer recall time feature) using the system class of service programming. Assign lines for direct department calling using the line class of service programming. Assign department stations, access codes to departments (flexible numbering feature), and busy/RNA timeout (call forward—busy feature) using the station class of service programming.

Departmental Calling Distribution (DCD) Report

The attendant station can request a Departmental Calling Distribution (DCD) report that provides a compilation of department call activity. The statistics that are reported are based on the department assignments that are active at the time of the report and are extracted from the SMDR records collected by the system. For a report to be generated, a department must exist. All calls that are included in the DCD report, must meet the following conditions before they are reported as department calls:

- They must be incoming calls. Outgoing calls are not reported in the DCD report.
- The port number of the line which received the call must be one that is assigned to a department.
- The port number of the station which answered the call must be assigned to a department.

A DCD report consists of the following columns of information:

Station Number: The station name or extension number of the station being reported.

Idle Time: The amount of time that the station is on-hook and available to answer a call.

Dept. Calls: The amount of time spent on incoming calls that rang into the department and calls that were transferred to the department.

Hold Time: The amount of time that department calls spent in an on-hold state at a particular station.

Avg. Dept. Calls: The average time per call (including on-hold time) that a station spent on a call.

Wrap-Up Time: The time that a station spent in a wrap-up mode doing such things as follow-up paperwork. While a station is in a wrap-up mode, it does not receive department calls. The station user sets a wrap-up mode by pressing **Hold** and **DND** and repeats the procedure to clear the wrap-up mode.

Missed Calls: The total number of calls that are not answered at a station and that are cycled by the system to another station for answering.

Other Calls: This is a summation of the time spent on outgoing call activity, incoming call activity on non-department lines, plus all intercom call activity.

On-Duty Time: The on-duty time includes a summation of idle time, department call time, wrap-up time, and other call time.

Off-Duty Time: The time that a station spent in a do not disturb mode. While in a do-not-disturb condition, a station is not available to receive calls. The station user sets a do-not-disturb mode by pressing DND and repeats the procedure to clear the do not disturb mode.

Unanswered Calls: Total number of calls that went unanswered at a department.

Calls Answered After 36 Seconds: Total number of calls that waited at least 36 seconds (approximately six rings from the CO) before being answered.

Calls Handled By Overflow Station: Total number of calls that were answered and transferred by the overflow station and then answered and serviced by another station.

Calls Terminated At Overflow Station: Total number of calls that were received by the overflow station and were either answered but not transferred or were dropped by the caller before being answered.

If you wish, you can enhance the DCD feature with digital voice announcing.

See also, *Digital Voice Announcing*.

Direct Inward Station Dialing (DISD)

The DISD feature allows an external party to call an intercom station directly without assistance by the attendant. The DISD call must be received on a line which has been specially programmed to allow this feature. Any line can be programmed to be a DISD line for both the normal mode of operation and the night transfer (of ringing) mode of operation.

The number of rings which occurs on a DISD line before it is answered is programmable. By setting a large number of rings, time is allowed for a call to be serviced in a regular manner by stations that have a line appearance for the DISD line. Setting the number of rings to 0 disables the line for DISD use. If a line is to be dedicated for DISD use, it is a good practice to set it for one ring. The amount of time allowed for an extension number to be dialed is programmable and a DISD assist station can be programmed to answer calls that are not completed during this dial time limit.

When a DISD line is called, it rings for a programmed number of rings. If the call is not answered in a normal manner by a station with the line appearance during this time, the system answers it and, if the programmer has chosen this feature, presents a DISD dial tone to the caller. The system then waits for an extension number to be dialed from the calling telephone. Only one DISD line is serviced at a time; therefore, an incoming call could ring for more than the programmed number of rings if a DISD call is being serviced when a second DISD call is received.

When a valid extension number is dialed, a confirmation tone is sounded, the system attempts a transfer, and the called station rings if it is idle. If a called station does not answer within the transfer recall timeout period, the call is returned to DISD dial tone. If the called station has the call forward feature set, the forwarded station rings. If a called station is busy, the call is placed on hold and camped-on at the busy station. The system will send a call waiting tone to the busy party if the programmer has enabled the call waiting tone feature. If the camp-on is not answered within the transfer recall timeout period, a busy tone is given followed by DISD dial tone. The system will return the caller to DISD dial tone two additional times and then drop the line (a total of three attempts are made).

NOTE: The system routes calls made to busy and ring-no-answer stations to an idle station in the hunt group. If no idle stations are available, the call is camped-on at the dialed station.

If an invalid extension number is dialed, an error tone is sounded before the DISD dial tone is returned. If a mistake in dialing is made, the caller can dial a * for a new DISD dial tone. The system will return the caller to DISD dial tone two additional times and then drop the line. If extension number dialing is not completed within the programmed dial time limit, the call is routed to the DISD assist station if one is programmed; otherwise, the line is dropped. The programmer may select a DISD dial time limit of 0 seconds, allowing callers to obtain a transfer to the assist station without having to dial any digits. If the assist station is busy (call will camp-on at the assist station) or if the assist station does not answer before the transfer recall timeout period, the system will return the caller to DISD dial tone. If extension number dialing is not completed within the dial time limit this time, the line is dropped.

The installer should connect a music source to the system so the music can provide a reassurance to the caller during a camp-on situation when the DISD feature is being used.

See also, *Digital Voice Announcing*

Direct Station Call Hold (Station Park)

This feature allows a station user to park a call at a specific station where it will be held without ringing. A feature code plus a station extension number can be dialed over the intercom line to park the call or a programmable button can be programmed to provide a “directed hold” to a specific station. The parked call is picked up by directed station by dialing a feature code. It can be picked up at any station through the use of the call pickup feature. No class of service is required.

See also, *Call Pick-Up—Directed and Call Park*.

Direct Station Selection (DSS) Programmable

A station user can store one-button, direct station selection (DSS) at any memory button location to create a DSS memory button. When this button is pressed, any active outside call is automatically placed on hold and an intercom call is automatically made to that previously stored station number. The visual indicators of the stations programmed at the button locations form a busy lamp field (BLF). The BLF conveys station status to the user. An autodial number can also be programmed as a secondary function at every DSS/BLF memory location. No class of service is required.

See also, *Automatic Dialing*.

Distinctive Ringing

The ringing cadence of an incoming call is the same as the ringing cadence of the TELCO, PBX, or CENTREX system. The ringing cadence of an intercom call presents two tone bursts sounded every four seconds.

See also, *Ringling*.

Do Not Disturb

Any station can be set to a do-not-disturb mode (DND) using the designated DND programmable button and associated indicator (indicator will light when DND is active). While in the DND mode, the station will not ring on any incoming call nor will it accept an intercom call. A party making an intercom call to a station set in the do-not-disturb mode hears a fast busy tone. The feature cannot be overridden by the calling party unless the override feature is enabled. The DND feature is used with the departmental calling feature to provide a station wrap-up mode and a station off-duty mode.

Do Not Disturb Inhibit

The system can be programmed to inhibit any station from entering the DND mode. System class of service programming is used to program this feature.

Do Not Disturb Override

Stations can be provided with DND override capability which will allow them to call a station that is set in the DND mode. The Executive/Attendant Override feature must also be active for DND override feature to function. Station class of service programming is used to assign this feature.

Dual Intercom

This feature provides for two separate intercom lines at the same station. One intercom line is fixed and is accessed with the Intercom button. The other intercom line is programmable and is accessed by a programmable button selected for that purpose by class of service programming. Calls are handled on the intercom lines in much the same manner as outside calls are handled using the line buttons.

Special considerations are as follows:

- Distant party hang-up causes intercom link to drop.
- Intercom call to station already busy on intercom rings in subdued fashion and flashes indicator associated with other intercom button.
- With both intercom lines busy, a third intercom call results in a subdued off-hook voice announce (if enabled) at busy station.
- Pressing a DSS button while on an active intercom call will drop the distant party unless the automatic hold feature is enabled for the intercom line through class of service programming.
The hold button can be used, however, to place an intercom call on hold before selecting the other intercom line for use.
- Any action taken on the intercom by a station being observed via the service observing feature will cause the observing station to return to an idle state.

The station class of service button mapping procedure assigns a programmable button to serve as the second intercom button.

See also, *Intercom*.

Dynamic Line Buttons

Through class of service programming, the programmer can arrange certain idle line buttons to serve as dynamic line buttons. This feature allows the system to temporarily assign a line to a station that normally does not have the line assigned to it, and have that line appear on a dynamic line button. While the call is appearing on the dynamic line button (LED on), any normal call handling operations can be performed. Station class of service programming allows certain buttons to be programmed as dynamic line buttons

E

End-To-End Signaling

End-To-End Signaling On Intercom

After an intercom call has been established with an analog telephony device that is connected to the system through the JM008 expansion module or ATI-D analog terminal interface device, the system can continue to send dialing signals (DTMF tones) through the intercom path. This feature can be performed from every station in the system, and is used by peripherals such as voice mail equipment.

End-To-End Signaling On Lines

After an outside call has been established, the system can continue to send dialing signals (DTMF tones) through the telco network and have them received at the distant end for inward call completion (bank by telephone, etc.). This conventional, off-hook dialing feature can be performed from every station in the system.

Exclusive Hold

Exclusive hold prohibits a held call from being retrieved by any other station. The exclusive hold condition also links a call on hold to the timed hold recall timeout feature. After timeout, the system causes audible and visual signaling to occur and reverts the exclusive hold condition to a normal line hold condition.

See also, *Hold*.

Exclusive Hold System-Wide Enable/Disable

This feature allows programmers to use system class of service programming to enable or disable exclusive hold capability on a system-wide basis.

See also, *Hold*.

Executive/Attendant Override

This feature allows the user of a station, upon encountering a busy signal at another station, to dial a code that will override the busy signal of a call, sound a warning tone, and allow access to the existing conversation. This feature is enabled through station class of service programming.

External Paging Interface

A dedicated paging port or a spare line port can be interfaced with an external paging amplifier. The paging amplifier can then be dial-accessed by stations in the system. DTMF tones can be dialed through the line port to provide zone selection if provided by the external paging amplifier. The dedicated paging port does not support any “talk-back” capability even if such a feature is provided by the external equipment. The line class of service programming arranges a line port for external paging interface. The system precedes an announcement through the paging port with an alerting tone. Programmers can choose between an intercom tone or a DTMF signaling tone for this paging alert tone. They should choose the intercom tone for a soft alert and choose the DTMF tone for a loud alert.

See also, *Paging*.

F

Feature Inhibit

A large array of individual features can be disabled system-wide to provide a basic telephone system. A basic telephone system is useful for installation environments where a large proportion of the stations are accessible to unauthorized users thus subject to tampering or for environments where station users must be limited as to the variety of features allowed to them. Features are disabled by system class of service. Once disabled, they can be enabled by turning on all features at once using the system default programming.

Flexible Ringing Assignments

Ringing assignments are programmable on a per station/per line basis. Ringing can be controlled for every line that has an appearance at each station. Delayed ringing is assigned to certain lines at each station through station class of service programming.

See also, *Ringing*.

Flexible Ringing Assignments Of PA Port

The PA port can be programmed for flexible ringing assignments and zone pages. Any desired lines can be programmed for direct ring, delay ring, or night transfer (of ringing) at this port. Paging can be to programmed zone or to all-call. A speaker can be connected to the PA port to sound the ringing that is generated by the system and sent to this port and paging announcements when they are sent to the programmed zone. Using such an arrangement, it is possible for a user to determine that certain lines are ringing, such as in a night transfer (of ringing) mode, and go to the nearest telephone and answer the call. The most common use for this arrangement is as a night bell eliminating the need for external equipment as required with the common ringer and auxiliary ringer interface. The speaker cannot be used for voice response as the path is one-way only. Use system class of service programming to assign ringing and paging to a PA port.

See also, *Ringing*.

Flexible Station And Line Class Of Service Control

The extension number of a station and all other programmable attributes that are initially assigned to a particular station port and the line, along with all programmable line attributes that are initially connected to a particular line port can be re-assigned to a different port through programming action. This feature allows adds, moves, and changes without re-locating the station and line wiring. A programmer can use line and station class of service programming are used to reassign stations and lines.

See also, *Class Of Service*.

Flexible Station Numbering Plan

The system supports a flexible station numbering plan for individual stations. Each station can be programmed to respond to the dialing of any available number between 10 and 7999. This feature may be used to match the calling number of a station located in a pre-numbered area to that area number. A combination of two, three, or four digit extension numbers can be assigned as long as they do not conflict. For example: If 21 is assigned as an extension number, there can not be any other extension number assigned that begins with a 21. The system class of service programming is used to assign extension numbers to individual station ports.

See also, *Square/Non-Square Configuration*.

Full Button Programmability Of Features

A programmer, or in many cases the users themselves, can make most system features available at programmable buttons merely by storing the specific access codes necessary for dialing the features. Storable features include those that can utilize lamp (on/off) supervision (e.g., call park orbits). The system will store all feature access codes except for those requiring Transfer/Conference button action. It will store continuous strings of digits (including presses of the intercom button) up to the maximum amount of storable digits (16) allowed in an autodial entry.

See also, *Programmable Buttons*.

H

Handsfree Answer Inhibit

The user can use the MUTE button to block all handsfree answerback response. This arrangement will prevent a station user from monitoring another station site using the monitoring ability of the voice announce feature. When a user presses the MUTE button, all handsfree answerback is disabled thus inhibiting any off-site monitoring. The MUTE light turns on steady to indicate that this feature is active.

See also, *Mute*.

Headset Capability

Certain proprietary LCD speakerphones include an auxiliary jack that provides an interface for a headset. To use a headset, the user merely plugs it into the telephone auxiliary jack and presses the appropriate button on his or her telephone to enable the headset mode. (In the case of Impression LCD speakerphones, users disconnect the handset and connect a headset in its place.) The telephone transfers its speakerphone function to the headset. To enhance the headset usefulness, the system delivers subdued off-hook voice announce (SOHVA) messages to the headset when it is in use.

Hold

Abandoned Hold Release

If an on-hold party hangs up at the CO/PBX end of a connection, causing an interruption in the line current, the system will drop the line from the hold condition and return it to service. The time interval between hang-up and line-drop is programmable in line class of service programming with choices of either 50 msec or 350 msec. This feature is usually dependent upon special arrangements that must be made at the CO end of the connection. The line select indicator will turn off to indicate an idle line after a call on that line has been abandoned.

Automatic Hold For Intercom

If a user selects the second intercom line while a call is active on the first intercom line, this automatic hold feature lets the system automatically place the first intercom call on hold. Use station class of service programming to enable this feature.

Automatic Hold—Transfer To Intercom (Answer Hold)

If a user selects the intercom line while an outside line call is active, this system feature causes the system to automatically place the outside call on hold. This feature does not require class of service programming to enable it.

Automatic Hold—Transfer To Line

A programmer can use class of service programming to make this system feature available to selected stations. When enabled, a user can press any line button and cause an active line to automatically go on hold. This feature allows a user to move from line to line without having to press the HOLD button to place any current calls on hold. Use station class of service programming to enable this feature at the desired stations.

Call Park

The call park feature is similar to a manual hold condition. A user can park a call a particular station and retrieve it at any station in the system by dialing the appropriate access code.

NOTE: The retrieving station must have access to the line on which the call appears.

Calls are parked and retrieved within the system through the use of dialing codes. The system provides nine parking circuits (orbits). Call park, when used with the paging features, allows a system attendant to direct calls to roving personnel. A call that is left in a parking orbit for preprogrammed length of time automatically returns to a timed hold recall condition at the station where the user originally parked the call.

Exclusive Hold

Exclusive hold prohibits a held call from being retrieved by any other station. The exclusive hold condition also links the held call to the timed hold recall timeout feature. After timeout, the system causes audible and visual signaling to occur reverts the exclusive hold condition to a normal line hold condition.

Exclusive Hold System-Wide Enable/Disable

This feature allows programmers to use system class of service programming to enable or disable exclusive hold capability on a system-wide basis.

Manual Hold

A button activated feature at each station will place an outside line on hold. When a user presses the HOLD button while on a call, the system places the call on hold, provides a distinctive flash rate of the line button indicator, and allows the user to access other station features. A user at the holding station or at any other station that has access to the line can retrieve the held call.

Timed Hold Recall

After a call has been on hold for a programmed length of time the system will re-call the station that placed the call on hold. The programmer sets the timed hold recall time period using system class of service programming.

I

I Hold And I Use Indications

The light associated with a line button provides a visual indication of the status of that line. When a station user has a line in-use or on-hold at a station, the light indication provided at that station is of a different color than the indication provided at the other stations in the system. No class of service programming is required.

Idle Line Preference

When a station is programmed for idle line preference, it will automatically be connected to the first assigned idle line. The system can be programmed on a per station basis to enable idle line preference. When idle line preference is enabled, taking the handset off-hook will automatically connect the station to any assigned line that is idle and has been arranged for this feature. The line button will not have to be pressed. If this feature is used in conjunction with prime line automatic, the user will be given prime line first when going off-hook. An idle line will be given if the prime line is in use. The station class of service programming enables this feature on a per station/per line basis.

See also, *Line Features*.

Impression Telephone Support

The digital telephone system supports the use of Comdial Impression digital telephones. This new proprietary digital telephone style is available in the following models:

2022S-FB and -PT	LCD Speakerphone
2122S-FB and -PT	Non-LCD Speakerphone
2122X-FB and -PT	Non-LCD Monitor Telephone
2101N-FB and -PT	Single Line Proprietary Telephone
DU32X-FB and -PT	32-Button DSS/BLF Console

Impression telephones are completely compatible with all of the features provided by the digital telephone system and require no unique programming.

Industry-Standard Telephone Support

The digital telephone system supports the use of an industry-standard telephone (IST) such as a model 2500. It does this through an the JM008 expansion module or ATI-D analog terminal interface.

An IST provides a full range of system features to the system telephone users and operates in one of two different modes as determined by the system installer. He or she may program the telephone to provide an intercom dial tone when a user lifts the handset. This arrangement is known as “prime intercom.” Alternately, the installer may program the telephone to provide outside line dial tone instead. This arrangement is known as “prime line automatic” or “idle line preference.” With prime intercom, users can dial the system feature codes as soon as they lift the IST’s handset. With prime line automatic or idle line preference, users must obtain intercom dial tone before dialing the various feature codes. They do this by pressing and releasing the hookswitch after they hear the outside line dial tone. This action either drops the outside line (if no digits are dialed after

the handset is lifted) or places the outside line on hold (if digits are dialed) and causes intercom dial tone to return to the IST.

Pressing and releasing the hookswitch is commonly known as flashing the hookswitch or performing a FLASH. Some ISTs are equipped with a TAP button, Users can press the TAP button to cause the same effect as performing a FLASH.

The system provides a feature that allows IST users to FLASH an outside line for some purpose (for example, to access a host system feature). Since flashing the IST hookswitch while on an outside line accesses the intercom dial tone, users must dial a code to actually generate the FLASH signal over the outside line.

Intercom Features

Automatic Callback

If a telephone user encounters a busy tone or a ring no-answer after calling an intercom station, She or he can dial a special code number that will cause the system to automatically ring both the user's telephone and the one that he or she was calling. This automatic callback occurs after the busy station becomes idle or after the user at the ring no-answer station takes some action at it that indicates to the system that it is available to be answered. No class of service programming is required to enable this feature.

Call Announce With Handsfree Answerback

The internal loudspeaker at each station provides call-announce capability over the intercom link. A user can make a handsfree response to a call-announce call without lifting the handset.

The user can use the MUTE button to block all handsfree answerback response. This arrangement will prevent a station user from monitoring another station site using the monitoring ability of the voice announce feature. When a user presses the MUTE button, all handsfree answerback is disabled thus inhibiting any off-site monitoring. The MUTE light turns on steady to indicate that this feature is active.

Dual Intercom

This feature provides for two separate intercom lines at the same station. One intercom line is fixed and is accessed with the Intercom button. The other intercom line is programmable and is accessed by a programmable button selected for that purpose by class of service programming. Calls are handled on the intercom lines in much the same manner as outside calls are handled using the line buttons.

Special considerations are as follows:

- Distant party hang-up causes intercom link to drop.

- Intercom call to station already busy on intercom rings in subdued fashion and flashes indicator associated with other intercom button.
- With both intercom lines busy, a third intercom call results in a subdued off-hook voice announce (if enabled) at busy station.
- Pressing a DSS button while on an active intercom call will drop the distant party unless the automatic hold feature is enabled for the intercom line through class of service programming.
The hold button can be used, however, to place an intercom call on hold before selecting the other intercom line for use.
- Any action taken on the intercom by a station being observed via the service observing feature will cause the observing station to return to an idle state.

The station class of service button mapping procedure assigns a programmable button to serve as the second intercom button.

Intercom Call Progress Tones

Intercom call progress is marked by special tones. A steady tone is provided for dial tone. Ring-back tone is one second on and three seconds off. For tone-signaled intercom calls, a two-tone burst is sounded every four seconds at a called station and returned to the caller as ring-back. For a voice signaled intercom call, a single tone burst is sounded at a called station. When a called station is busy, a busy signal of one-half second on and one-half second off is received at the calling station. The system supplies a fast busy tone when the called station is in the do not disturb mode. Analog terminal interface ports are only supplied with the regular busy tone since fast busy tones could interfere with the operation of some accessories that can be connected to this port.

For more information, see section 1.7.2, *System Ringing Patterns*.

Intercom Hunt Group

Station ports can be assigned to intercom hunt groups. When a station that is assigned to a hunt group is busy or is a ring-no-answer (RNA), a call to it will ring at the next idle station in the group. A hunt group can be terminal or circular. A call will route down a terminal group from the called station until it finds an idle station or reaches the end of the group. A call will search around a circular group until it encounters an idle station or until all stations in the circular group are searched. The ringing time at anyone station is programmable. Hunt groups are created through station class of service programming.

Intercom Line Timeout

Should the intercom line be selected with no dialing or other action taking place, the intercom will timeout after 15 seconds, and return to an idle state.

Tone Or Voice Signaling

The system allows intercom calls to be tone signaled or voice signaled as the users desire; however, the programmer uses system class of service programming procedures to determine which signaling method the system will employ as the primary method. Regardless of the programmer's arrangement, telephone users can take action to use the alternate method when they need it. See the paragraph titled *Intercom Call Progress Tones* for a discussion of the intercom signaling tones.

Voice Announce Blocking

This feature allows station users to block voice announced intercom signaling by dialing a code or pressing a programmable button programmed for that purpose. The programmable button used to block voice signaling is enabled by station class of service programming.

K

Key System/Hybrid Configuration

The system can operate as either a key system (KF designation) or as a hybrid system (MF designation). In the past, this digital telephone system provided a hardware strap that installers could move to distinguish between hybrid system and key system operation; however, recent rulings by the FCC have eliminated the need for the hardware strap. Therefore, whenever the programmer assigns lines to line groups, the system automatically assumes the hybrid mode.

The KF and MF designations are equipment type categories as stipulated in FCC rules and regulations, Part 68, and appear as part of the FCC Registration Number on the equipment label. The installer must report the appropriate registration number to the telephone company at the time of connection along with other FCC mandated information. Operationally, the hybrid configuration allows dial access to (automatic selection of) outgoing lines. The specific system feature that is enabled by the multifunction (hybrid) configuration is *Line Group (Including Dial Access)*. Since this is a PBX type feature, it may incur a higher monthly tariff to the telephone company.

L

Last Number Redial

Each station is provided with a last number redial feature. This feature will save 32 digits of the last outside number dialed. A newly dialed number will always automatically replace a previously dialed number. Upon command, the system will choose a line and redial the saved number. The system will first choose the prime line if assigned and idle. If it is busy or unavailable, the system will choose any line assigned to idle line

preference. If they are unavailable, the system will chose the last line used at the station. If it is busy, no further choice is made. No class of service is required.

See also, *Redialing*.

LCD Messaging

Standard and system-supplied custom display messages can be set by dialing a specific code at any station. Such messages are to be received and displayed by any LCD speakerphone that calls the station which set the message. When a message is set, the intercom light at the setting station will flash to indicate that the feature is active.

See also, *Messaging*.

LCD Support

The system supports the use of digital telephones having a Liquid Crystal Display (LCD). The display is capable of providing the station user with a visual presentation of: call cost, call duration, number dialed, name of called station, name of active feature, date and time, and programming prompts.

Interactive Button Support

The LCD speakerphone provides the user with three interactive buttons and expanded LCD displays as a standard feature. The interactive buttons provide the user with quick, easy access to system features and straightforward button programming without dialing codes. The expanded displays prompt the telephone user on the operation and progress of many of the telephone features and provides designations for the interactive buttons. Since the interactive buttons provide many user features, their immediate functions vary with the feature. The button functions change to match the feature that the user is currently operating. At any given time, the current button designations show in the display window.

Button Query

Station users who have LCD speakerphones can use their interactive buttons to access the button query feature. With this feature, the station user can cause his or her LCD speakerphone to show the function of each of its buttons on its display.

Line Features

Access Denied, Line Access Restriction

The system programmer can deny access to particular lines at certain stations in the system. A station user cannot select a denied line for use. This feature is programmable on a per line/per station basis in station class of service programming.

Line Answer From Any Station (Night Mode)

When the attendant programs the system for nighttime operation using the night transfer of ringing feature, the line answer from any station feature is made active. With this feature, a user can dial an access code over the intercom line to allow him to answer any ringing outside line. The line need not be ringing at the user's station for this feature to be used.

Idle Line Preference

When a station is programmed for idle line preference, it will automatically be connected to the first assigned idle line. The system can be programmed on a per station basis to enable idle line preference. When idle line preference is enabled, taking the handset off-hook will automatically connect the station to any assigned line that is idle and has been arranged for this feature. The line button will not have to be pressed. If this feature is used in conjunction with prime line automatic, the user will be given prime line first when going off-hook. An idle line will be given if the prime line is in use. The station class of service programming enables this feature on a per station/per line basis.

Line Groups

Outside lines can be grouped together in up to four different groups. Users can program an autodial button to select a line group or manually enter a dialing code for access to a line. Grouping can reserve certain lines for certain clusters of stations as in a tenant-service arrangement. The assignment of line groups frees station buttons normally used for line selection thus making these buttons available for use with a feature such as personal DSS/BLF with station-to-station messaging. Lines are placed in line groups with the line class of service programming.

Line Preselection

A line can be manually selected before lifting the handset (for handsfree dialing) or after the handset is lifted.

Line And Line Group Queuing

With the line queuing feature, the station user can take action that will place a station in a queue where it awaits the availability of a line or line group. The station is automatically signaled with five-ring bursts when the line is available to it for use. Each station can queue one line at a time.

Originating Denied

The ability to originate calls on certain lines can be denied at individual stations through system programming. The originating denied feature is programmed on a per station/per line basis. Originating denied does not prevent a user from answering a ringing line, retrieving a held call or receiving a transferred call. Call origination on a line is denied at a particular station by the station class of service programming.

Prime Line Automatic

If the programmer uses station class of service programming to enable prime line automatic at a station, the system will automatically select the designated outside line, intercom line or line group when the user lifts the handset. A user can pre-empt prime line pickup by preselecting another line before lifting the handset. If the prime line is ringing, it is automatically answered when the user lifts the handset.

Ringing Line Preference

The system can be programmed on a per station basis to provide ringing line preference on all lines programmed for ringing at the station. When ringing line preference is enabled at a station, taking the handset off-hook automatically connects the station to any outside line that is ringing at it. A line button will not have to be pressed. With ringing line preference enabled, the telephones denote a ringing line with an orange colored status light. If a station also has prime line assigned, the prime line will always be answered first even though it may be the second line to ring. The ability of a particular station to answer a ringing line without line selection is enabled by the station class of service programming.

M

Manual Hold

A button activated feature at each station will place an outside line on hold. When a user presses the HOLD button while on a call, the system places the call on hold, provides a distinctive flash rate of the line button indicator, and allows the user to access other station features. A user at the holding station or at any other station that has access to the line can retrieve the held call.

See also, *Hold*.

Meet-Me Answer Page

Any station user can dial a special code number in response to an all-call or zone page and be connected to the paging party in a private conversation. All-call or zone paging is provided to the stations through the station class of service programming.

See also, *Paging*.

Memory Retention Without Batteries

The system memory is electronically protected during AC power failures by an electronic device sometimes known as a “super cap.” The stored program data will remain in memory for a minimum of 60 hours provided that the system has been powered continuously for at least 30 minutes prior to the power failure or disconnection. Also, the system clock will continue to run and keep time for at least 30 minutes after an AC power failure or disconnection.

Messaging

Assist Button

This feature allows a station user to program a button to be used for sending a message to an LCD speakerphone. Once programmed, the station user can press the ASSIST button at anytime to ring the called station and present a preprogrammed message in the station display. The user can send a message while on a call without alerting the distant party. This feature is useful for requesting assistance while engaging on a call. For example, a customer service representative could request assistance from a supervisor while talking to a problem caller. The supervisor, upon receiving the tone and noting the display message, could perform an executive override or service observing action to join the call or monitor it.

LCD Messaging

Standard and system-supplied custom display messages can be set by dialing a specific code at any station. Such messages are to be received and displayed by any LCD speakerphone that calls the station which set the message. When a message is set, the intercom light at the setting station will flash to indicate that the feature is active.

Message Waiting

Special feature access codes enable a station user to control the message waiting (MW) light at other stations in the system. When the message waiting light is turned on at a station, a call can be automatically placed to the station that turned it on.

Alternately, one station can be designated by COS programming as the central message desk and can be arranged for exclusive message waiting control. The central message desk can be used to control message waiting lights and deliver messages to and from all other stations in the system. The ability of a station to originate a message waiting signal is enabled by programming action. Station class of service programming provides a station with the ability to originate a message waiting signal and is used to create a central message desk. The system defaults the message wait originate feature as enabled.

Response Messaging

This feature allows a user to reply in a non-verbal manner to a voice announce or tone-sigaled intercom call or to a subdued off-hook voice announce call if the intercom caller is using an LCD speakerphone. A station user can press a programmable button in response to an intercom call and send a message to be shown on the display of the calling station. Response messages are pre-programmed by the attendant and later stored by station users at programmable buttons on their individual stations as need dictates.

Station-To-Station Messaging

If a station has a DSS/BLF appearance at another station, a callback message indication can be left at that station with the DSS/BLF appearance. The user can dial a special code to turn on the BLF light at the called station that is assigned to the calling station. This light indicates that a callback is requested. The light is automatically turned off if a successful callback is made.

If a station number is not programmed for a DSS/BLF appearance at another station, attempting to place a call back message will cause the central message desk station to ring. If there is no central message desk assigned, no action will occur.

Modular Wiring And Jacks 2- Or 4-Conductor Wire System

The system can be completely interconnected by employing industry standard 50-pin connectors and modular plug/jack combinations. Station wiring is number 22 or 24 gauge, 2-conductor, twisted-pair cable throughout the system. If the installer uses 4-conductor twisted-pair cable, it provides a spare pair for a separate wiring purpose when needed.

Music Features

Background Music

If the installer connects a customer-provided external music source to the system, the music from that source will sound through the station loudspeakers after the users turn it on at their stations. They can adjust the loudness of this background music with the loudspeaker volume control. The system automatically turns the background music off during calls. This feature requires no class of service programming.

Music Interface

The common equipment cabinet includes an input jack where the installer can connect a customer-provided music source.

Music-On-Hold

When an installer connects a customer-provided music source to the system through the music interface jack, the system supplies that music to the outside lines that users place on hold.

Music-On-Hold System-Wide Enable/Disable

After the installer has arranged for the system to supply customer-provided music to calls that users place on hold, the attendant can disable the feature on a system-wide basis.

Mute

Every monitor telephone and speakerphone has a MUTE button which, when pressed, will mute the handset transmitter (or internal microphone on speakerphones) to prevent the user's voice from being heard by the distant party. The MUTE light turns on steady to indicate a muted condition. The MUTE button provides push-on/push-off operation on speakerphones. No class of service is required.

Handsfree Answer Inhibit

The user can use the MUTE button to block all handsfree answerback response. This arrangement will prevent a station user from monitoring another station site using the monitoring ability of the voice announce feature. When a user presses the MUTE button, all handsfree answerback is disabled thus inhibiting any off-site monitoring. The MUTE light turns on steady to indicate that this feature is active.

N

Night Transfer (Of Ringing)

Night transfer (of ringing) is an attendant-controlled feature that transfers the day ringing program of all incoming calls to a particular station or stations for off-hour or special purpose answering. The night transfer mode can only be activated from station 10 or 12. The individual lines at each station that are to be transferred with this feature are selected by station class of service programming.

See also, *Ringling*.

O

On-Hook Dialing

Every monitor and speakerphone provides manual and/or automatic dialing while the station handset is on-hook. The telephone loudspeaker monitors call progress for completion. (The handset must be taken off-hook to provide the voice link on non-speakerphone stations.)

Originating Denied

The ability to originate calls on certain lines can be denied at individual stations through system programming. The originating denied feature is programmed on a per station/per line basis. Originating denied does not prevent a user from answering a ringing line, retrieving a held call or receiving a transferred call. Call origination on a line is denied at a particular station by the station class of service programming.

See also, *Line Features*.

P

Paging

All-Call Paging

All-call paging allows all stations to receive announcements through the station speaker at once. The system can also send all-call paging to the paging port where it applies it to the input of an external paging amplifier. Origination of announcements must be via the station handset. A programmer can arrange each station to receive and/or originate all-call page. He or she enables the ability to receive and originate all-call paging at a station through station class of service programming.

External Paging Interface

A dedicated paging port or a spare line port can be interfaced with an external paging amplifier. The paging amplifier can then be dial-accessed by stations in the system. DTMF tones can be dialed through the line port to provide zone selection if provided by the external paging amplifier. The dedicated paging port does not support any “talk-back” capability even if such a feature is provided by the external equipment. The line class of service programming arranges a line port for external paging interface. The system precedes an announcement through the paging port with an alerting tone. Programmers can choose between an intercom tone or a DTMF signaling tone for this paging alert tone. They should choose the intercom tone for a soft alert and choose the DTMF tone for a loud alert.

Meet-Me Answer Page

Any station user can dial a special code number in response to an all-call or zone page and be connected to the paging party in a private conversation. All-call or zone paging is provided to the stations through the station class of service programming.

Zone Paging

Zone paging allows groups of stations to receive announcements through the station speakers. The programming can enable zone paging in up to four different zones. Zone paging can also be received at the paging port where it can be connected to the input of an external paging amplifier. The ability of each station to originate and/or receive a page and the arrangement of the paging into different zones are controlled by station class of service programming. Zone paging through the paging port is enabled by system class of service programming.

PBX/CENTREX/CO Compatible

System features and programmable buttons support the requirements of most PBXs, Central Offices, and CENTREX systems. Numbers, #'s, *'s, programmable pauses, and flash signals can be made a part of every stored number for access to host system feature codes.

Personal Computer Interface Unit (PCIU)

The Personal Computer Interface Unit (PCIU) is a device that you can connect between a digital station port and its proprietary telephone. The PCIU allows telephone users to initiate telephone and voice mail related functions from their personal computer (PC).

The PCIU includes Service Provider Interface (SPI) software on computer diskettes. With this software installed on the user's PC, the PC users can employ their Telephony Applications Programming Interface (TAPI), third-party Microsoft* Windows applications programs to control many useful telephone functions.

When the Visual Voice Processing (V.V.P.) Visual Call Manager (VCM) software option is available, the voice mail system can use the serial data path to the PCIU to send messages to the telephone's display and to the SPI on the PC.

*Microsoft is a registered trademark of Microsoft Corporation, Redmond, Washington

Personalized Ringing Tone

The system provides a group of distinctive tones for station ringing. A station user can choose a tone from this group to provide a distinctive ring at his or her telephone. Often, when several telephones are located close to each other, each user chooses a different personal ring tone. The system provides six distinctive tones for users to choose from.

See also, *Ringing*.

Pooled Line Access (Line Group Access)

Outside lines can be grouped together in up to four different groups. Users can program an autodial button to select a line group or manually enter a dialing code for access to a line. Grouping can reserve certain lines for certain clusters of stations as in a tenant-service arrangement. The assignment of line groups frees station buttons normally used for line selection thus making these buttons available for use with a feature such as personal DSS/BLF with station-to-station messaging. Lines are placed in line groups with the line class of service programming.

See *Line Features*.

Power Failure Transfer

An installer can connect an industry-standard telephone such as the model 2500 to a special connection to serve as a power-fail telephone. If an AC power failure occurs, the system automatically connects the power-fail telephone directly to an outside line. Users can make normal origination and reception of calls on a power-fail telephone during an AC power failure. The system will automatically disconnect the power-fail telephone from the outside line as soon as AC power returns.

Prime Line Automatic

If the programmer uses station class of service programming to enable prime line automatic at a station, the system will automatically select the designated outside line, intercom line or line group when the user lifts the handset. A user can pre-empt prime line pickup by preselecting another line before lifting the handset. If the prime line is ringing, it is automatically answered when the user lifts the handset.

See also, *Line Features*.

Privacy

Automatic Privacy

A programmer can make a line private or non-private through programming. In the private mode, a station has exclusive use of the line during a call. No other station can access that line unless the user of the private line adds another station through the use of the add-on conference feature. In the non-private mode, another station with that line appearance can gain access at the same time (sometimes known as common line pickup). A line is specified as private or non-private through the line class of service programming. Through station class of service programming, a programmer can make a line non-private at a particular station.

See also, *Conferencing*.

Privacy—Designated Programmable Button

The programmer can arrange for stations to provide a privacy button. If a line is private, a user can press the privacy button to change it into a non-private one. If the line is non-private, pressing the button will have no effect. Station class of service programming is used to program the programmable button function at the stations.

Privacy Release/Brokerage Service

See the previous paragraph titled *Privacy—Designated Programmable Button*

Private Lines (Access Denied)

The system programmer can deny access to particular lines at certain stations in the system. A station user cannot select a denied line for use. This feature is programmable on a per line/per station basis in station class of service programming.

See also, *Line Features*.

Programmable DSS/BLF

A station user can store one-button, direct station selection (DSS) at any memory button location to create a DSS memory button. When this button is pressed, any active outside call is automatically placed on hold and an intercom call is automatically made to that previously stored station number. The visual indicators of the stations programmed at the button locations form a busy lamp field (BLF). The BLF conveys station status to the user. An autodial number can also be programmed as a secondary function at every DSS/BLF memory location. No class of service is required.

See also, *Automatic Dialing*.

Programmable Buttons

A programmer, or in many cases the users themselves, can make most system features available at programmable buttons merely by storing the specific access codes necessary for dialing the features. Storable features include those that can utilize lamp (on/off) supervision (e.g., call park orbits). The system will store all feature access codes except for those requiring Transfer/Conference button action. It will store continuous strings of digits (including presses of the intercom button) up to the maximum amount of storable digits (16) allowed in an autodial entry.

Programming Password Protection

No one can enter a programming mode to reprogram the system without first entering a password. The system provides two different entry levels for programming and allows for a different password for each entry. The two programming entry levels are the installer level and the administrator level. Programmers can enter the installer level, using the installer password, to perform all programming functions including major changes such as master clearing and line type programming. They can enter the administrator level, using the administrator password, to perform most programming functions except those major changes just mentioned. Programmers can use the VDT programming method to change the passwords from their default values as needed to provide security against unauthorized program entries. They can do this when the system is initially installed and programmed, or at any later time as needed. Additionally, programmers can construct a password that will prevent all COS programming entry from station 10. Customized passwords can be alpha-numeric or numeric only (no spaces allowed) and must contain six characters. To retain the ability to enter programming from station 10, programmers must maintain the I*nnn* format in the VDT password and enter only numbers in the nnn entry; however, they must not enter a zero for the leading n. Once customized, a password remains customized. Neither default nor master clear will erase it. Programmers must use the new password to gain entry into the system for future programming tasks. It is very important that someone keep a hard copy of the customized password since it provides the only entry to system COS programming through either the VDT or station 10. If no one can remember the customized password, the manufacturer can provide emergency entry but there is a charge for this service. Otherwise, the installer must disconnect all AC power and any battery back up equipment, wait at for an extended period of time (up to several weeks) for the internal memory protection to completely discharge, and reprogram the system using the default password to gain entry.

Pulse/Tone Switchable

The programmer can program the system on a per line basis using the line class of service programming to allow the stations to switch from pulse to DTMF type dialing as needed. Alternately, she or he can program the system to only allow tone dialing.

R

Redialing

Automatic Redial (Of Busy Number Or Unanswered Call)

A user can automatically redial a busy number or unanswered call by activating this feature. Once the user activates automatic redial, the station will select the line, automatically dial the number, and wait for a response. It will do this once a minute for approximately 10 minutes unless the user deactivates the feature by pressing that button or another button or by lifting the handset. The feature cycle is timed and does not have busy detection circuitry. Because of this, if the user is operating handsfree when the called party answers, she or he must lift the handset to prevent the caller from being cut off by the timing cycle. The automatic redial button is a designated programmable button position and the user must program its location to make it active.

Automatic Pause Insertion

When the system stores a dialed number for later redial, it automatically stores a pause whenever the user waits between digits for at least two seconds. The system inserts the automatic pause in the stored number sequence at the point where the manual pause in dialing occurred. The length of the automatic pause is programmable.

Last Number Redial

Each station is provided with a last number redial feature. This feature will save 32 digits of the last outside number dialed. A newly dialed number will always automatically replace a previously dialed number. Upon command, the system will choose a line and redial the saved number. The system will first choose the prime line if assigned and idle. If it is busy or unavailable, the system will choose any line assigned to idle line preference. If they are unavailable, the system will choose the last line used at the station. If it is busy, no further choice is made. No class of service is required.

Saved Number Redial

This feature enables a button action to save the first 16 digits of the last number manually dialed from the keypad. The saved number can be redialed at a later time. The saved number is permanently available for later use until it is replaced with a new number.

When the caller identification feature is active, this saved number redial feature will save the Caller ID number for redial.

Response Messaging

This feature allows a user to reply in a non-verbal manner to a voice announce or tone-signaled intercom call or to a subdued off-hook voice announce call if the intercom caller is using an LCD speakerphone. A station user can press a programmable button in response to an intercom call and send a message to be shown on the display of the calling station. Response messages are pre-programmed by the attendant and later stored by station users at programmable buttons on their individual stations as need dictates.

See also, *Messaging*.

Remote Programming And Administration

Both remote class of service programming and the transmission of SMDR data for printing are available through serial data ports. The system supports X-on X-off terminal control codes as well as a DTR signal for handshaking. The system data communications operates per the popular XMODEM protocol. The database can be uploaded or downloaded, error free, from or to a remote computer that is running software that supports the XMODEM protocol. The two serial data ports allow VDT programming (either local or remote) to be conducted through one port at the same time that the other port is being used to send SMDR data for printing. VDT programming of the system is menu driven.

See also, *Class Of Service*.

Ringer Volume Control

DigiTech, *Impact*, and Impression telephones have a ringer volume control that telephone users can operate to adjust the loudness of the ringer at his or her station.

Ringling

Auxiliary Ringer Interface

The auxiliary ringer interface provides “dry-contact” relay closures which track the ringing pattern whenever the system sends ringing to a programmable destination. Programmers can program relay control to be activated when the system sends ringing to station port 17 or to the paging port.

When programmed for station port 17 ringing, an installer often uses an external device to provide loud ringing. When programmed for paging port ringing, an installer often installs an external paging amplifier to sound the rings. The system supplies ringing tones to the paging port along with the relay closures. It can send the ringing tones to the input

of an external paging amplifier and the installer can arrange the wiring so that the relay closures energize the paging amplifier while it is receiving the ringing tone. Use system class of service programming to choose either the paging port, or station port 17 for the ringing port relay control. Also use system class of service to determine the type of ringing sent to the paging port. Use station class of service programming to determine the type of ringing that the system sends to station port 17.

Programmers can arrange for the system to send ringing tones for particular lines through the PA port. They can choose between intercom tone and DTMF signaling tone for the PA port ringing. They should choose the intercom tone if they desire a soft tone and the DTMF tone if they desire a loud tone.

Common Audible Ringer Interface

Connections are available at the common equipment that provides “dry-contact” relay closures whenever an incoming line rings. These contact closures track the ringing pattern and can be used to control an external signaling device.

Delayed Ringing

Ring assignments are programmable. A station can be programmed to provide delayed ringing on some lines while providing immediate ringing on other lines. Delayed ringing is assigned to certain lines at each station through station class of service programming. When a programmer assigns delayed ringing to a station for certain lines, he or she can also assign the time length of the delay.

Distinctive Ringing

The ringing cadence of an incoming call is the same as the ringing cadence of the TELCO, PBX, or CENTREX system. The ringing cadence of an intercom call presents two tone bursts sounded every four seconds.

Flexible Ringing Assignments

Ring assignments are programmable on a per station/per line basis. Ringing can be controlled for every line that has an appearance at each station. Delayed ringing is assigned to certain lines at each station through station class of service programming.

Flexible Ringing Assignments Of PA Port

The PA port can be programmed for flexible ringing assignments and zone pages. Any desired lines can be programmed for direct ring, delay ring, or night transfer (of ringing) at this port. Paging can be to programmed zone or to all-call. A speaker can be connected to the PA port to sound the ringing that is generated by the system and sent to this port

and paging announcements when they are sent to the programmed zone. Using such an arrangement, it is possible for a user to determine that certain lines are ringing, such as in a night transfer (of ringing) mode, and go to the nearest telephone and answer the call. The most common use for this arrangement is as a night bell eliminating the need for external equipment as required with the common ringer and auxiliary ringer interface. The speaker cannot be used for voice response as the path is one-way only. Use system class of service programming to assign ringing and paging to a PA port.

Night Transfer (Of Ringing)

Night transfer (of ringing) is an attendant-controlled feature that transfers the day ringing program of all incoming calls to a particular station or stations for off-hour or special purpose answering. The night transfer mode can only be activated from station 10 or 12. The individual lines at each station that are to be transferred with this feature are selected by station class of service programming.

Night Transfer (Of Ringing) Button

A night transfer of ringing, or night mode, button is available at attendant stations. The night mode button gives attendants at stations 10 and 12 the ability to place the system into the night transfer of ringing mode of operation by simply pressing one button instead of entering the multiple keystroke sequence previously required. The night mode button toggles the feature on and off with one keystroke and the light located above the Intercom button on attendant telephones flutters to indicate when the night transfer or ringing is active.

Personalized Ringing Tone

The system provides a group of distinctive tones for station ringing. A station user can choose a tone from this group to provide a distinctive ring at his or her telephone. Often, when several telephones are located close to each other, each user chooses a different personal ring tone. The system provides six distinctive tones for users to choose from.

Subdued Ringing

When a station is busy on a call and another call comes to the same station, the system will automatically subdue the ringing of the second call to a lower volume.

Ringling Line Preference

The system can be programmed on a per station basis to provide ringing line preference on all lines programmed for ringing at the station. When ringing line preference is enabled at a station, taking the handset off-hook automatically connects the station to any outside line that is ringing at it. A line button will not have to be pressed. With ringing line preference enabled, the telephones denote a ringing line with an orange colored status light. If a station also has prime line assigned, the prime line will always be answered first even though it may be the second line to ring. The ability of a particular station to answer a ringing line without line selection is enabled by the station class of service programming.

See also, *Line Features*.

S

Saved Number Redial

This feature enables a button action to save the first 16 digits of the last number manually dialed from the keypad. The saved number can be redialed at a later time. The saved number is permanently available for later use until it is replaced with a new number.

When the caller identification feature is active, this saved number redial feature will save the identified number for redial.

See also, *Redial*.

Scout 900MX Digital Wireless Telephone

The DSU II supports the Scout 900MX Digital Wireless Telephone. The Scout telephone is a 900 megahertz, spread-spectrum, wireless telephone. While the Scout operates much like an *Impact* telephone, you should note that a few operational differences do exist. The “Call Announce Receive” and “All Call Receive” features require that you install and enable a headset. The Scout does not support the “Autoredial” or “voice response to SOHVA.” It is a good idea to program any Scout telephone station port with “Delayed Ringing” to an ExecuMail port or attendant station in case the user is out of range when he or she receives a call.

The Scout does have a range test that the installer or user can perform. Comdial highly recommends that the installer perform a preliminary on-site range test to make sure the Scout meets the customer’s needs (for more information on how to use the range-test feature, see GCA70-308).

There is no limit to the number of Scout telephones that you can install on a system. However, because of channel restrictions, only nine Scouts can be in use at one time

within the same general area. If all nine channels are in use and a tenth Scout telephone tries to place a call, the LCD will indicate “System Busy” and deny the call. If you do install more than one Scout wireless telephone, Comdial recommends that you leave at least 10 feet between adjacent base units. The range of each Scout telephone is affected by the layout and location of the base unit, so it is a good idea to install the base unit in an unimpeded area and at desk-level or higher.

The Scout handset has three programmable buttons and one intercom button that give you access to the telephone system’s features. Depending on the feature, either the end-user or the system programmer can set these buttons. Scout does not require any additional programming.

Self Diagnostics

Each station can execute a self test when so enabled by anyone who wishes to do so. This test verifies processor, indicator, and tone functions.

Service Observing

Service observing allows a third party to enter an in-progress call in an unannounced muted mode to monitor the conversation. The system does not send any warning tones when the call entry is made. This feature is useful in allowing a supervisor to monitor the performance of an employee during a phone conversation with a client. For a station to provide the service observing feature, it must also have the executive override feature enabled. When the programmer enables the service observing feature, the system automatically enables the executive override feature as well. A programmer can enable or block service observing (and executive override) at each desired station using station class of service programming procedures.

Speakerphone Support

The digital telephone system’s speakerphone support enables a speakerphone’s ability to originate handsfree operation for voice-signaled intercom calls in addition to all of the other features that it normally provides.

Specialized Route Access

The digital telephone system provides a specialized route access feature that, when enabled, allows the system to select a line group based on the digits the user has dialed. By doing this, it matches calls with their best suited routes. The feature provides a table-driven routing scheme where the numbers that users dial cause the system to chose

a line group after comparing the dialed number with entries that are contained in an office code table, an area code table, and four special area code look-up tables.

The specialized route access operates in the following manner: When the caller presses INTERCOM and dials 9 or presses a preprogrammed button, the system returns a special dial tone. The caller then has 10 seconds in which to dial some digits; otherwise, the telephone will return to its idle state. Once a caller begins to dial digits, he or she has a certain period of time in which to dial each new digit. The system programmer selects this time-out period through programming. After the caller has stopped dialing digits and the end of the time-out period has occurred, the system analyzes the dialed digits and routes the call by following the table-driven routing scheme depending upon how the programmer has arranged the system.

The system routes calls based on comparison matches between the dialed number and the entries that it finds in either an office code table, an area code table, or four special tables for selected area codes. These tables contain 1000 entries from 000 to 999 and the programmer can assign one line group to each entry; therefore, a routing match is always possible.

The system matches dialed digits with table entries in the following manner:

- If the first digit that the caller dials is not a 1 or a 0, and if he or she dials less than 10 digits (such as : nnn-nnnn), the system evaluates the first three digits as an office code, searches for the office code in the office code table, and finds a line group.
- If the first digit is either a 1 or a 0 (such as: n-*nnn-nnnn*), the system ignores the first digit and evaluates the next three digits as an office code, searches for the office code in the office code table, and finds a line group,
- If the first digit that the caller dials is neither a 1 nor a 0, and if he or she dials 10 digits or more (such as *nnn-nnn-nnnn*), the system evaluates the first three digits as an area code and the following three digits as an office code.
- If the first digit that the caller dials is either a 1 or a 0 (such as *n-*nnn-nnn-nnnn**), the system ignores the first digit, evaluates the next three digits as an area code, and evaluates the following three digits as an office code.
- After digit evaluation the system routes the call as per the following discussion: If there is a special table that matches the dialed area code, the system searches that table for the dialed office code and finds a line group. If there is not a special table for that area code, the system just searches the area code table for it and finds a line group.

The following information illustrates the digit evaluation scheme.

Digit Evaluation

Quantity Of Digits Dialed	Actual Dialed Digits	Digits Evaluated By System To Find Line Group
2	67	067
3	118	118
4	5123	512
7	9782200	978
8	19782200	978
10	8049782200	804, 978
11	18049782200	804, 978

The example below shows how calls to area code 202 are routed using line group 2, calls to office code 202 are routed using line group 1, calls to office code 973 in area code 716 are routed using line group 4, and all other calls are routed using line group 1.

Routing Calls Through Different Line Groups

			Special Tables For Selected Area Codes (Each table is for office code entries in a specific area code.)			
Entries 000-999	Office Code Table	Area Code Table	Area Code 1 (716)	Area Code 2 ()	Area Code 3 ()	Area Code 4 ()
000	1		1			
001	1		1			
002	1		1			
202	1	2	1			
212	1	1	1			
973	1		4			
997	1		1			
998	1		1			
999	1		1			

The programmer can arrange for the system to insert up to eight digits (including * and # as well as 0-9) ahead of a dialed number for a selected line group. Further, the programmer can enter a pause of system-determined length as a character in the digit string.

To help understand this digit insertion, review this typical arrangement for transparent CENTREX operation (This example assumes that the CENTREX extensions do not conflict with the office codes.): With the digital telephone system installed behind a CENTREX system, callers can make outgoing calls without having to dial 9. Assume

that the CENTREX extensions are 3300–3399. Take programming action to assign line group 2 to entries 330–339 in the office code table. This means that calls on CENTREX extensions will use line group 2 and all other calls will default to use line group 1. Program the 9 digit as the insertion digit for line group 1. With this set up, when a caller dials a number other than a CENTREX extension, the system automatically inserts a 9 ahead of the dialed digits and routes the call over line group 1.

If no lines are free in a selected line group, the system will route the call to an overflow line group if the programmer has assigned one; otherwise, the system will return busy tone to the caller.

NOTE: If the programmer has arranged for the system to insert digits on a particular line group, he or she should consider arranging for the system to insert digits in the overflow line group as well. This consideration is necessary only if it is important for the call to route through the same common carrier as was the original line group.

While line group dialing codes 81, 82, and 83 do not provide access to the SRA feature, they could provide a means of bypassing SRA by allowing users access to line groups outside of the SRA process. To insure that the system routes all calls through SRA, programmers should use the feature inhibit programming procedure to inhibit dialing codes 81, 82, and 83.

Using Specialized Route Access For Simplified Toll Restriction

In anticipation of the implementation of the revised North American dialing plan, the SRA feature provides the system with the ability to deny calling to designated area or office codes. The programmer merely assigns a line group that contains no assigned lines to the designated office or area code. This prevents the system from routing calls for dialed numbers containing those particular area or office codes since there is no line available. This action will work only for manually dialed numbers because automatically dialed numbers, with no line preselect, employ the last used line and therefore cannot be restricted.

Square/Non-Square Configuration

A programmer can arrange for a system to be square or non-square as desired. In a square system, the line 1 buttons of all telephone stations select line 1, the line 2 buttons select line 2, etc. In a non-square system, each line select button at every station may be assigned individually to select any line. A programmer can perform unique button mapping for line appearance on each station using the station class of service programming.

Flexible Station Numbering Plan

The system supports a flexible station numbering plan for individual stations. Each station can be programmed to respond to the dialing of any available number between 10 and 7999. This feature may be used to match the calling number of a station located in a pre-numbered area to that area number. A combination of two, three, or four digit extension numbers can be assigned as long as they do not conflict. For example: If 21 is assigned as an extension number, there can not be any other extension number assigned that begins with a 21. The system class of service programming is used to assign extension numbers to individual station ports.

Tenant Service

A system programmer can arrange for one telephone system to be used for multiple tenants at a site location by employing flexible line appearance at each station. The programmer can perform button mapping for line appearance on each station in the system using the station class of service programming.

Station Monitoring With DSS Call Pickup

The busy lamp field (BLF) of a station can provide visual indication of the idle, busy, and ringing status of monitored stations. This monitoring station can also provide audible indication of any direct and delayed ringing that occurs at the monitored station if the programmer has enabled the visual ring indication feature. A user at the monitoring station can make a one-button pickup of a ringing call at a monitored station by pressing the direct station selection (DSS) button associated with the ringing station.

The programmer can enable or disable the flashing BLF lights associated with visual ring indication on a system-wide basis. When the programmer enables the flashing lights, he or she can then enable the audible indication of ringing on a station-by-station basis.

Station Speed Dial

Each station provides 10 speed dial number locations at the keypad buttons. Station speed dial numbers can be up to 16 digits in length and can include line or intercom selection, numbers, #, *, pauses, and hookflash signals. A user can store a pause by pressing the HOLD button and store a hookflash signal by pressing the TAP button.

See also, *Automatic Dialing*.

Station-To-Station Messaging

If a station has a DSS/BLF appearance at another station, a callback message indication can be left at that station with the DSS/BLF appearance. The user can dial a special code to turn on the BLF light at the called station that is assigned to the calling station. This light indicates that a callback is requested. The light is automatically turned off if a successful callback is made.

If a station number is not programmed for a DSS/BLF appearance at another station, attempting to place a call back message will cause the central message desk station to ring. If there is no central message desk assigned, no action will occur.

See also, *Messaging*.

Subdued Off-Hook Voice Announce

With the subdued off-hook voice announce (SOHVA) feature, a user can make a voice announcement from one station to another station that is off-hook and busy on a call. A station being operated in a handsfree mode cannot receive a SOHVA. With SOHVA, the caller delivers the call and the user receiving the call responds to it in a secure manner that prevents the distant party from hearing either the announcement or the response. The system precedes the announcement with a tone alert that it delivers to the handset receiver of the called telephone. It also supplies a tone to the announcing caller to alert them that they are making a SOHVA call. A programmer can set the quantity of tone bursts from one to six. A user can respond to the SOHVA announcement either verbally or non-verbally. He or she either effects a verbal response by pressing and holding the MUTE button and speaking into the handset or effects a non-verbal response by pressing a pre-programmed button to send a message to be shown on the display of the announcing station (if it is an LCD speakerphone). The system automatically disconnects the announcing station after it delivers the response message to it (and displayed if an LCD speakerphone). Stations that have the voice announce blocking feature turned on cannot receive a SOHVA. A programmer can use station class of service programming to disable the SOHVA feature at a station port if desired.

Subdued Off-Hook Voice Announce Originate Button

This feature allows a telephone user to program a button at his or her station that she or he must press before delivering a SOHVA call. This SOHVA enabled button allows a caller, after hearing a busy signal, to decide whether to interrupt the called party in a SOHVA manner. If the caller decides that the called should be interrupted, the caller can press the button and complete the SOHVA call. This button, along with SOHVA groups, allows system users greater control of the callers that are allowed to make SOHVA calls and of the situations in which they are allowed to make them.

Subdued Off-Hook Voice Announce (SOHVA) Groups

The programmer can program the ability of station ports to originate and/or receive SOHVA calls by assigning SOHVA calling groups to station ports. This means that he or she can arrange certain station ports together for SOHVA calling between one another while excluding other station ports in the system from this group.

The system provides eight different SOHVA groups that are fixed into a variety of SOHVA receive/originate configurations. A programmer can assign one SOHVA group to each station port to allow or to deny SOHVA receive and/or originate capability to it. By properly assigning SOHVA groups to station ports, the programmer can open or block SOHVA paths between stations.

The system is defaulted with no SOHVA groups assigned. When a station port does not have a SOHVA group assigned to it, it's user can originate SOHVA calls to any station port and receive SOHVA calls from any station port.

SOHVA groups are *fixed* by the system into the following configurations:

SOHVA Groups and Their Configurations

SOHVA Group	Group Configurations							
Group 1	1	2	3	4	5	6	7	8
Receive From	X							
Originate To	X	X	X	X				
Group 2	1	2	3	4	5	6	7	8
Receive From	X	X						
Originate To		X	X	X				
Group 3	1	2	3	4	5	6	7	8
Receive From		X	X					
Originate To			X	X				
Group 4	1	2	3	4	5	6	7	8
Receive From	X	X	X					
Originate To								
Group 5	1	2	3	4	5	6	7	8
Receive From					X			
Originate To					X			
Group 6	1	2	3	4	5	6	7	8
Receive From						X		
Originate To						X		
Group 7	1	2	3	4	5	6	7	8
Receive From							X	
Originate To							X	
Group 8	1	2	3	4	5	6	7	8
Receive From								X
Originate To								X

Example 1: Allow station port 10 to originate SOHVA messages to all stations in the system and allow those stations the ability to originate SOHVA messages to each other but not to station port 10. Assign group 1 to station port 10 and assign group 2 to all other station ports.

Example 2: Allow station ports 14 and 15 to receive and originate SOHVA calls between each other but deny both receive and originate capability from any other system stations. Assign group 8 to both station port 14 and station port 15. Do not assign group 8 to any other station port *but be sure that all station ports have a group assigned to them.*

The programmer assigns SOHVA groups using the station class of service programming procedure.

Subdued Ringing

When a station is busy on a call and another call comes to the same station, the system will automatically subdue the ringing of the second call to a lower volume.

See also, *Ringling*.

System Alarm Reports

The programmer can arrange the system to report alarm and status conditions to a particular station or stations that he or she has enabled to receive them. The alarm receiving station must be an LCD speakerphone. When a station is enabled to receive alarms, its user can take appropriate action to cause the alarm codes to be presented on the LCD display. A programmer must use both system and station class of service programming to enable this feature.

System Speed Dial

The system provides 99 system-wide speed dial numbers. The system speed dial numbers can be up to thirty-two digits in length, and can include numbers, #, *, pauses, and hookflash signals. The attendant programs the system speed dial numbers and names at station 10 or 12 for use at every station in the system. No class of service programming is required.

See also, *Automatic Dialing*.

T

Tandem Attendant

When the programmer uses system class of service programming to enable the tandem attendant feature, a recall from an unanswered call transfer or a timed hold recall will ring at the normal attendant station (station 10) that set the transfer or hold condition, and also ring at the tandem attendant station (station 12).

TAP (Flash/Recall)

If the host system provides custom calling features via a hookflash signal, the programmer should program the system so that the TAP button will generate a “flash” signal when a user presses it. If custom calling features are not available to digital telephone system users, the programmer should program the TAP button to function as a positive disconnect, dial tone recall button. The flash and recall features are mutually exclusive. The programmer uses the system class of service programming procedures to set the flash or recall TAP time.

Tenant Service

A system programmer can arrange for one telephone system to be used for multiple tenants at a site location by employing flexible line appearance at each station. The programmer can perform button mapping for line appearance on each station in the system using the station class of service programming.

See also, *Square/Non-Square Configuration*.

Timed Hold Recall

After a call has been on hold for a programmed length of time the system will re-call the station that placed the call on hold. The programmer sets the timed hold recall time period using system class of service programming.

See also, *Hold*.

Toll Restriction

Default Toll Restriction

The system defaults two toll restriction tables with pre-programmed values and pre-assigned to all lines. The programmer needs only to assign these tables to the stations by programming action to put them into effect. He or she can use the toll restriction table configuration class of service programming to reprogram the defaulted tables with different information as needed.

Flexible Toll Restriction

A system programmer can configure system toll call restriction to prohibit some or all stations from calling a wide range of number combinations. The restricted numbers are specified on up to 16 tables. The system assigns several broad-range values to two of these tables, and assigns the tables to all lines as a default condition. The programmer needs only to enable the default tables on a per station basis to activate the default toll restriction.

In general, toll restriction works as follows:

The programmable tables of restricted numbers can contain up to four entries and each entry can contain up to 16 digits.

A programmer programs each table of restricted numbers to be an “allow” table or a “deny” table with entries in an “allow” table overriding entries in a “deny” table. This arrangement allows the programmer to enable exceptions to toll restriction. For example, he or she can arrange the table entries so that the system allows the dialing of 1-800-xxx-xxxx numbers even though it denies the dialing of all 1-xxx-xxx-xxxx numbers. A programmer can store a “match anything” symbol (#) to represent any digit from 0 to 9 in the individual entries thus providing him or her with a broad range of number combinations to choose from.

The programmer can individually assign the programmed toll restriction tables to each appropriate station and line. Therefore, when an outside call is dialed, the system examines the dialed number and makes a comparison between it and the toll restriction tables. Any tables that the programmer assigned to BOTH the station being used and the selected line determine the restrictions to be imposed. It should be noted that the system will automatically disconnect a line from a station if its user dials a restricted number on a restricted line from a restricted station.

Night Mode Toll Restriction

A programmer can assign toll restriction tables to any or all stations in the system that will only take effect when the system is in the night transfer (of ringing) mode. These toll

tables replace any that he or she may have assigned to the station for normal, or day mode, operation. For example: a programmer can arrange for a station that has no other toll restriction table assignment to receive a toll restriction table which will restrict everything but local calls and will only take effect when the system is placed in the night transfer (of ringing) mode. Therefore, even though users can make toll calls from this station during daytime operation, they can make no toll calls from it when the attendant programs the system for nighttime operation using the night transfer of ringing feature.

NOTE: Do not confuse this night mode toll restriction table assignment with the night transfer (of ringing) feature.

Toll Restriction Override

The toll restriction override (TRO) feature allows users to override the toll restriction that they encounter at other stations with their own station's toll restriction assignments. In programming for this feature, the programmer creates a four-digit TRO code that users can dial to override the toll restrictions of any station that they happen to be using and replace it with a toll restriction that matches their home station. After entering a TRO code, a user gets his or her own prime line or idle line preference and its accompanying toll restriction assignment. They then have 15 seconds to dial an outgoing call. Once they hang up from a call, they have 15 seconds to make another call without having to re-enter their TRO code. The system marks outgoing line calls that users make after entering a TRO code with a (T) in its SMDR/SMDA printouts. The station number that it prints is that of the overriding station and not the actual station that the call was made from. If a user transfers a TRO call or places it on hold and picks it up at another station, the call belongs to the new station.

Positive Disconnect Supervision

When a station is on line with an outside caller and the caller hangs up, the CO may send a positive disconnect signal to the telephone system. A programmer can enable a positive disconnect supervision feature on a per line basis. With this feature enabled when the telephone system detects the CO's positive disconnect signal, the system resets the toll restriction, releases the current call record, and creates a new call record in its place.

Tone Or Voice Signaling (Intercom)

The system allows intercom calls to be tone signaled or voice signaled as the users desire; however, the programmer uses system class of service programming procedures to determine which signaling method the system will employ as the primary method. Regardless of the programmer's arrangement, telephone users can take action to use the alternate method when they need it. See the paragraph titled *Intercom Call Progress Tones* for a discussion of the intercom signaling tones.

See also, *Intercom*.

Tracker Paging System

The optional Tracker Paging System is a wireless paging system that uses an external base station connected to the common equipment cabinet and individual portable pagers assigned to the system station extension numbering plan. The Tracker Paging System allows telephone users to send alpha/numeric or numeric-only messages to Tracker pagers assigned to station extension numbers. The type of message that the system delivers is dependent on the model Tracker pager being used. The Tracker base station requires only one connection to the digital telephone system; however, the installer will need to take several programming steps to make it operational.

Transferring Calls

See *Call Transfer*.

Transfer/Conference Button

The telephones provide this fixed button that gives quick, easy transferring and conferencing.

U

Unanswered Call Transfer Recall Timing

A transferred call that is unanswered after a pre-programmed length of time will return to the station that transferred it. The system will return the call to both attendant stations when the tandem attendant feature is enabled. When LCD speakerphones are employed, the display will show the station number or name as well as the line number that is being re-called. The system class of service programming determines the recall time for an unanswered call transfer.

See also, *Call Transfer*.

Unscreened Call Transfer

A user can transfer a call to another station without first announcing it. The transferred call will camp-on to the other station where it will ring and await an answer. The call will automatically ring back to the transferring station after a programmable recall period. There is no limit as to how many calls users can camp-on to another station. A transferred call will only ring if the station is idle. If the station is busy, the call will wait until it is idle before it rings. The programmer can use the system class of service programming to set the recall time for an unanswered transferred call.

See also, *Call Transfer*.

V

Visual Voice Mail Support

Visual Voice Mail (VVM) support provides proprietary, two-line display LCD speakerphone stations with visual messages and interactive buttons. This message and button functionality enhances the stations with visual messages and interactive buttons. This message and button functionality enhances the station's use with Comdial Versatile Voice Processing (VVP) voice mail equipment. To implement VVM support, the system programmer must enable it with class of service programming action. Since VVM requires the same serial data connection to the common equipment cabinet as does the Tracker Paging System, the Tracker Paging System is unavailable while VVM is operational.

When enabled, VVM causes the speakerphone to display a **VMAIL** button that users press to call the voice mail system. After they press this button, the system prompts them to enter a password. (This password is one that the programmer assigns to the stations.) Once users enter the password, the speakerphone's display shows the VVP's main menu. From there, users can select the operation they wish to pursue.

When there is a message waiting, the display shows the message quantity in place of the **VMAIL** button (for example, **5 MSG**). Users press the **MSG** button to play the stored messages. The system prompts the user to enter a password (if programmed to require one) before it plays the new messages.

Voice Announce Blocking

This feature allows station users to block voice announced intercom signaling by dialing a code or pressing a programmable button programmed for that purpose. The programmable button used to block voice signaling is enabled by station class of service programming.

See *Intercom*.

Voice Mail Support

The digital telephone system supports the use of voice processing equipment connected to the system's station ports through the ATI-D analog terminal interface. The ATI-D is a multipurpose *on-premise* accessory for the digital telephone system. It has dual circuits that allow the voice mail equipment to interface to two station ports. In addition to the required programming task of identifying the station ports as voice mail ports, there are several other programming considerations associated with voice mail operation that the programmer can make whenever their options are wanted. These options include the following features:

Automatic Attendant

With the automatic attendant feature, the voice mail system automatically answers any line that is ringing at a voice mail port. As a default, the system automatically enables ringing line preference for any port the programmer identifies as voice mail ports. The programmer must choose a ringing assignment for the lines assigned to the voice mail port before the voice mail system can provide the automatic attendant feature.

Automatic Transfer Of Voice Mail

The programmer can choose the immediate transfer mode for voice mail transfers. However, if he turns on the screen and/or confirm options provided by the voice mail system, he must not choose the immediate transfer mode because it allows the system to transfer a call as soon as it answers it precluding any screen and confirm action that the voice mail equipment can provide.

Hunt Groups

When a station port that has been assigned to an intercom hunt group is busy, a call to it will ring at the next idle station port in the group. A call will try to ring every port in a hunt group and if all are busy, the telephone system will return a busy tone to the caller. A programmer can assign all voice mail ports to a circular hunt group to take advantage of its multiple-port interface capability. With this arrangement, a call will first try to ring at the first port, then try the next one and so forth until it tries all four ports.

Positive Disconnect Supervision

When a station is on line with an outside caller and the caller hangs up, the CO may send a positive disconnect signal to the digital telephone system. The system passes this signal to the voice mail equipment thus signaling it also to hang up.

Voice Mail Line ID

The programmer can program the voice mail lines with identification (ID) numbers that allow the voice mail equipment to identify which line it is answering. The ID numbers that the programmer assigns here must match the ID numbers that are selected as part of voice mail system programming.

Voice Mail Pause

Some voice mail systems allow you to program a pause before they dial an extension number. You can program the digital telephone system to pause before receiving digits from a voice mail system. This capability allows the digital telephone system to match the voice mail system's pause. If the voice mail system does not pause before dialing an extension number, you must disable the fixed one second pause in the digital telephone system.

Voice Mail Transfer On Busy

The programmer can arrange the telephone system to alert a busy telephone that the voice mail equipment is attempting to transfer a call to it. Without this programming, the voice mail equipment will automatically route the call to a voice mail box when it encounters a busy signal. With this option, when the voice mail equipment tries to transfer a call to a station that is busy on a call (outside or intercom call) and the station has an available intercom line (stations can be programmed to have a second intercom), the intercom will ring subdued. The user can answer the call by pressing the button of the ringing intercom line. In general, attendants will probably desire this feature so they can handle multiple calls, while other station users may prefer to have a message taken when they are already busy on a call.

Volume Control

Every *Impact*, *Impression*, *DigiTech*, and *Scout* telephone has a multipurpose volume control for adjusting the loudness of the ringer, the speaker, the handset, the headset, and the group listening mode. LCD speakerphones display the new volume setting whenever the user presses the rocker switch volume control located on the telephone's faceplate.

There are four ringer levels (*Scout* has two plus off). At default system settings, users can set the ringer loudness at their stations from completely off to maximum. System

programmers may disable the ringer-off feature on a system-wide basis. When programmers take this option, users can set the ringer volume to a low level but cannot completely silence it.

The number of handset loudness levels is different for the different telephone models. The DigiTech telephones have 8 handset volume settings. At default, *Impact* and *Impression* telephones have 8 handset volume settings, but the installer may increase the number of volume settings on individual stations to 13. Users working in noisy environments and users with hearing impairments may find the increased number of volume settings useful. The Scout has two handset volume levels.

There are 8 headset volume levels on DigiTech telephones, 13 on *Impact* and *Impression* telephones and two on Scout telephones. *Impact*, *Impression*, and DigiTech telephones have 8 speaker volume levels. DigiTech telephones have 7 group listening volume levels, *Impact* and *Impression* telephones have 8.

Z

Zone Paging (Via Station Speakers)

Zone paging allows groups of stations to receive announcements through the station speakers. The programming can enable zone paging in up to four different zones. Zone paging can also be received at the paging port where it can be connected to the input of an external paging amplifier. The ability of each station to originate and/or receive a page and the arrangement of the paging into different zones are controlled by station class of service programming. Zone paging through the paging port is enabled by system class of service programming.

See also, *Paging*.



Index

A

Abandoned Hold Release 3-35, A-1, A-36
 AC Power Connection 2_8
 Access Codes For Direct Department Calling 3-95
 Access Denied 3-46, A-1
 Access Denied, Line Access Restriction A-43
 Accessory Information 1_5
 Account Codes A-23-86
 Button 3-78, A-4
 Configuration Records 4-19
 Display Time For 3-90
 Enabled or Disabled 3-88
 Entry, Verified 3-91
 Forced or Optional Entry 3-88
 Length 3-86
 List 3-87
 Add-On Conferencing A-18
 Add-On Expansion Module
 Installing 2-46
 Using 2-41
 Alarm Reporting 3-25
 Alarm Report Enabling 3-25
 Alarm Report Stations 3-25, 3-75
 All-Call and Zone Paging 3-47
 All-Call Paging A-49, A-4
 Analog Terminal Interface 1-5
 Installing 2-64
 Configuration Records 4-21
 Support A-4
 Answer Hold A-36
 Area Code Band Tables (Long Distance Calls) 3-124
 Area Paging Interface A-5
 Assign Entries To Toll Restriction Tables 3-145
 Assign Toll Restriction
 Override (TRO) Code 3-149
 To Lines 3-147
 To Stations 3-147
 To Stations For Night Transfer 3-148
 To System Speed Dial Calls 3-148
 Assigning A SAVE Button 3-167
 Assigning Caller ID Lines 3-165
 Assigning Caller ID Stations 3-165
 Assist Button A-45, A-5
 ATI Support 1-5, A-4
 ATI-D Installation 2-64

Audible First Ring Feature (For Caller ID) 3-166
 Audible Monitoring 3-24, 3-49
 Auto Station Logon 3-112
 Automatic Attendant A-72
 Automatic Callback A-5, A-39
 Automatic Dialing A-6
 Of Stored Numbers A-6
 Extended DTMF Tones For 3-31
 Automatic Hold 3-50
 Automatic Transfer To Intercom A-36
 Automatic Transfer To Line A-7, A-36
 For Intercom A-7, A-36
 Automatic Pause Insertion A-7, A-54
 Automatic Privacy Release 3-36
 Automatic Privacy 3-36, 3-51, A-51
 Automatic Redial A-7, A-54
 Automatic Station Relocation 3-16, A-8
 Automatic Transfer of Voice Mail 3-108, A-72
 Auxiliary Equipment Interface A-8
 Using 2-29
 Auxiliary Lines 3-40
 Auxiliary Ringer Interface A-8, A-55

B

Background Music A-9, A-47
 Basic Key Service (1A2) Emulation A-9
 Battery Back Up Assembly, Installing The 2-60
 Battery Back Up 1-6, A-9
 Blank Buttons 3-79
 Block Programming A-10, A-16, 3-11, 3-43, 3-76
 Button Designations, Converting 3-9
 Button Mapping The Stations 3-77
 Button Query A-42
 Buttons, Interactive 3-63

C

Cabinet Mounting 2_6
 Cable Clips, Installing The 2-17
 Call Announce With Handsfree
 Answerback A-10, A-39
 Call Costing 3-114
 And SMDA Reports A-10
 Flow Diagram Examples 3-115
 Call Forward
 Button 3-79
 Busy/Ring-No Answer 3-52, 3-98

Call Forwarding	A-12	Connecting	
Of Busy Calls	3-52	Lines	2-12
Of RNA Calls	A-12, 3-52	Stations	2-16
On All Calls	A-12, A-12	VVP Voice Mail System	2-86
Personal	A-12	Considering The Mounting Requirements	2-4
Call Origination Denied	3-54	Console Support	A-19
Call Park	A-14, A-36	Converting Button Designations	3-9
Orbit Button	3-80	Creating Data Security Groups	3-161
Recall Time	3-30	<u>D</u>	
Call Pickup	A-14	Data Baud Rate	3-17
Call Rate Tables	3-125	Data Connections	
Call Transfer	A-14	Making Modular Jack	2-34
Call Waiting Tone	A-15	Making The Common Equipment	2-36
Enable/Disable	3-102	Data Devices, Connecting To The System	2-34
Call-Back Button	3-78	Data Interface Unit Records	4-48
Caller ID	1-6, A-15	Data Interface Unit	3-160, A-20
Configuring COM 2 Serial Data Port For	3-166	Installing	2-72
Assigning Lines	3-165	Data Parameters, Setting The	3-153
Assigning Stations	3-165	Data Printer Operation, Enable	3-103
Service Support	2-76, 3-162	Data Printer Service	3-103
Service Support Configuration Chart	4-42	Data Security Port	3-55
Setting The Distribution	3-167	Data Security	A-21
Calling Station Identification On BLF	A-16	Day Answer Messages	A-23
Central Message Desk	3-54	DCD	
Central Office Lines	3-40	Department Transfers Before Disconnect	3-155
Checking		Operation, Programming For	3-155
General Operating Conditions	2-49	Report	A-27
Resistance	2-48	Default Functional Program	A-17, A-21
System Status Indicator	2-49	Default Toll Restriction	A-21, A-68
Voltage	2-48	Defaulting	
CID08 Installation	2-76	Button Assignments	3-13
Class Of Service	A-16	Lines	3-12
Program Printout	A-17	Stations	3-13
Programming From Main Station	A-16	System	3-12
Programming From VDT	A-17	Toll Restriction Tables	3-13
Clock	3-26	Delayed Ringing	A-22, A-56
Common Audible And Auxiliary Ringing Interface		Departmental Calling Distribution Report	A-22, A-27
Connecting Outside Lines	2-30	Describing	
Connecting Selected Ports	2-30	Common Equipment	1-8
Connecting The	2-30	Stations	1-10
Common Audible Ringer Interface	A-18, A-56	Designated Programmable Buttons	A-22
Common Equipment, Describing The	1-8	Detailing The Accessory Information	1-5
Conferencing	A-18	Detailing The Line Connections	2-14
Configuring Serial Data Port For Caller ID	3-166	Dial 0 For System Attendant	A-22
Connecting A Power Failure Station	2-28	Dial By Name	A-22
Connecting A VDT For Remote Programming	2-38	Dial Time Limit	3-100
Connecting Data Devices To The System	2-34	Digital Voice Announcing (DVA)	3-154, A-23
Connecting Stations		Digital Voice Announcing Records	4-45
To The J0408	2-19	DigiTech Telephone	
To The J0816	2-20	Descriptions	1-10
To The J1632	2-21	Supporting Revision I And Later	3-8
Connecting The Common Audible And Auxiliary Ringing Interface	2-30		

Direct Department Calling	3-94	End-To-End Signaling	A-32
Access Codes	3-95	On Intercom	A-32
Call Forward On Busy/Ring—No Answer	3-98	On Lines	A-32
Line Ports	3-95	Exception Tables	3-121
Records	4-22	Exclusive Hold	3-19, A-32, A-37
Station Ports	3-96	System-Wide Enable/Disable	A-32, A-37
With Departmental Call Distribution	A-25	Executive Override	3-56
Direct Inward Station Dialing (DISD)	A-28, 3-99	Executive/Attendant Override	A-33
Records	4-23	Extended DTMF Tones For Automatic Dialing	3-31
Direct Station Call Hold (Station Park)	A-30	External Paging Interface	A-33, A-49
Direct Station Selection (DSS) Programmable	A-30	Using	2-32
Directed Call Pickup	A-14	F	
Discard Digits	3-127	Failure Isolation	2-49
DISD (Direct Inward Station Dialing)	A-28, 3-99	FCC Registration Numbers	2_5
Assist Station	3-101	FCC Rules And Regulations	2-88
Incoming Rings	3-102	Feature Codes	1-22
Operation, Programming For	3-156	Features Inhibit	3-29, A-33
Records	4-23	Flash/Recall	A-67
Display Time For Account Codes	3-90	Flexible Ringing Assignments	3-33, A-56, A-57
Distinctive Ringing	A-30, A-56	Of PA Port	A-34, A-56
DIU (Data Interface Unit)	1-6, 3-160	Flexible Station And Line COS Control	A-17, A-34
Creating Data Security Groups	3-161	Flexible Station Numbering Plan	A-34, A-63
Data Buttons, Programming	3-160	Flexible Station Numbering	3-60
Installation	2-72	Flexible Toll Restriction	A-68
Records	4-48	Forced Account Code Entry For CENTREX	A-4
Remote Data Station	3-161	Forced or Optional Entry Account Codes	3-88
Do Not Disturb (DND)	A-30, 3-18	Full Button Programmability Of Features	A-35
Button	3-80	Fuses, Identifying The	2_8
Inhibit	A-31	G	
Override	A-31	Grounding The System	2-10
Drop Message	A-24	Grounding The Unused Station Cables	2-17
DSS/BLF Button	3-81	Group Call Pickup	3-60, A-14
DSS/BLF Console	1-6	H	
Installing	2-26	Handset Volume Control On <i>Impact</i> Telephones	3-61
DTMF Tones For Automatic Dialing	3-31	Handsfree Answer Inhibit	A-35, A-48
Dual Console Feature	3-55	Hardware, Summarizing The	1_7
Dual Intercom	A-31, A-39	Headset	
DVA (Digital Voice Announcer)	1_6, 3-154, A-23	Capability	A-35
Enabling/Disabling	3-157	Interface	3-62
Programming The Messages	3-158	Operation	1-5
Operation Support	2-82	Hold	A-36
Records	4-45	Hunt Groups	A-72
Dynamic Line Buttons	A-32	Hybrid Installation	2-5
E		I	
Enable		I Hold And I Use Indications	A-37
Data Printer Operation	3-103	Identifying The Fuses	2-8
Special SRA Area Code Tables	3-133	Idle Line Preference	3-64, A-38, A-43
SRA Office And Area Code Tables	3-131	Impact Telephone Descriptions	1-12
The SRA Feature	3-130	Impression Telephone	
The Tracker Pagers For Stations	3-153	Descriptions	1-14
The Tracker Paging System	3-152	Support	A-38
Enable/Disable		Industry-Standard Telephone Support	A-38
Call Waiting Tone	3-102	Inhibiting DISD Digit Dialing	3-100
Account Codes	3-88	Inhibiting System Features	3-29
Digital Voice Announcing (DVA)	3-157	Insert Digits For SRA	3-135

Installing		Loading And Up-Grading The System Software	2-50
Add-On Expansion Module	2-46	Loading The Software	2-52
Analog Terminal Interface	2-64	Locating User Information	1-3
Battery Back Up Assembly	2-60		
Cable Clips	2-17	<u>M</u>	
Data Interface Unit	2-72	Making Modular Jack Data Connections	2-34
DSS/BLF Consoles	2-26	Making The AC Power Connection	2-8
Personal Computer Interface Unit	2-84	Making The Common Equipment	
System Options And Accessories	2-60	Data Connections	2-36
Integrated Call Costing	3-114	Manual Hold	A-37, A-45
Configuration Records	4-27	Master Clearing and	
Interactive Button Support	A-42	Defaulting The System	2-57, 3-11, 3-12
Interactive Buttons	3-63	Meet-Me Answer Page	A-45, A-49
Intercom Call Progress Tones	A-40	Memory Retention Without Batteries	A-45
Intercom Features	A-39	Message Wait Originate	3-66
Intercom Hunt Group	3-53, A-40	Message Waiting	A-46
Intercom Line Time-out	A-40	Messaging	A-45
Introducing The Software Disks	2-51	Modular Wiring And Jacks,	
Introducing The Software Key	2-50	2- or 4-Conductor Wire System	A-47
Isolating Failures	2-49	Mounting The Cabinet	2-6
IST		Multiline Conferencing	A-18
Distinctive Ringing	3-93	Multiple Intercom Button	3-83
Interface	3-92	Music Features	A-47
Through Dialing	3-93	Music Interface	A-47
<u>J</u>		Using The	2-40
JM008 Module	2-41, 2-44	Music On Hold	3-19, A-47
		System-Wide Enable/Disable	A-47
<u>K</u>		Mute	A-47
Key System/Hybrid Configuration	A-41	<u>N</u>	
<u>L</u>		Night Answer Messages	A-24
Last Number Redial	A-41, A-54	Night Mode Toll Restriction	A-68
LCD		Night Mode	A-43
Messaging	3-20, A-42, A-46	Night Transfer (Of Ringing) Button	A-57
Speakerphone Display Of Costed Calls	3-129	Night Transfer (Of Ringing)	A-48, A-57
Support	A-42	Non-Square Configuration	3-77, A-62
Line And Line Group Queuing	A-44	<u>O</u>	
Line		Office Code Band Tables (Local Calls)	3-122
Answer From Any Station (Night Mode)	A-43	On-Hook Dialing	A-48
Line		Options And Accessories, Installing	2-60
Button	3-82	OPX Long Loop Adapter Installation	2_70
Configuration Records	4-11	Originating Denied	A-44, A-48
Connections	2_12, 2_14	Overlay	
Disable	3-37	7700S Telephone	4-49
Features	A-43	7714X And 7714S Telephones	4-51
Group Access	A-50	7714X, 7714S, And 7700S Telephones	4-53
Group Button	3-82	8012S And 8112S Telephones	4-57
Group Queue Button	3-83	8024S And 8124 Telephones	4-55
Groups	3-37, A-43	DD32X-xx	4-59
Names	3-38	IB64X	4-61
Port Functions	3-40	Impression DSS/BLF Console	4_65
Port Reassignment	2_14	Impression Telephone	4_63
Ports For Direct Department Calling	3-95	<u>P</u>	
Preselection	A-43	PA Port Options	3-22
Programming	3-35	Paging Interface, Using A Line Port	2-33
Protection	2_14	Paging	A-49
Port Re-Assignment	3-41		

Password Protection					
Programming		3-14			
Records		4-3			
Pause Time		3-32			
PBX/CENTREX/CO Compatible		A-50			
Personal Computer Interface Unit (PCIU)		A-50			
Installation		2_84			
Personal Ringing Tones		3-65			
Personalized Ringing Tone	A-50, A-57				
Pooled Line Access (Line Group Access)		A-50			
Port Reassignment		3-74			
Positive Disconnect					
Supervision	3-44, 3-110, 3-150, A-69, A-73				
Power Failure Station, Connecting A		2-28			
Power, AC Connection		2_8			
Prime Line Automatic	3_66, A-44, A-51				
Prime Line, Prime Group, And Prime Intercom		3-66			
Privacy Button		3-84			
Designated Programmable Button		A-51			
Privacy Release		3-51			
Privacy Release/Brokerage Service		A-52			
Privacy		A-51			
Private Lines (Access Denied)		A-52			
Private or Non-Private Line	3-51, 3-36				
Programmable Buttons		A-52			
Programmable DSS/BLF	A-6, A-52				
Programming					
Block		3-11			
Data Buttons		3-160			
DCD Operation		3-155			
DISD Operation		3-156			
DVA Messages		3-158			
Overlays	3-11, 4-49, 4-51, 4-53 4-55, 4-59, 4-61, 4-63, 4-65				
Password Protection		3-14, A-53			
Using A Telephone		3-7			
Toll Restriction Table Entries		3-146			
Understanding System		3_17			
Using A Telephone		3-7			
Using A VDT		3-11			
Protecting The Lines		2-14			
Publications, Related		1_3			
Pulse Dialing		3-42			
Pulse/Tone Switchable	3-42, A-53				
R					
Reassigning The Line Ports		2-14			
Recall Messages		A-24			
Recall Time, Unanswered Call Transfer		3-34			
Recall/Flash		3-32			
Recording					
Account Code Configurations		4-19			
IST Configurations		4-21			
Integrated Call Costing Configurations		4-27			
Line Configurations		4-11			
Specialized Route Access Configurations		4-33			
Station Configurations		4-13			
Toll Restriction Table Configurations		4-37			
Voice Mail Interface Configurations		4-24			
Redialing		A-54			
Relay Tracking of Ringing		3-23			
Relocating The Stations		2-17			
Remote Data Station		3-161			
Remote Programming And Administration	A-18, A-55				
Repair Assistance, Seeking		1-25			
Resistance Checking		2-48			
Response Messaging	A-46, A-55				
Ringer Volume Control		A-55			
Ringer, Allow Off		3-59			
Ringing		A-55			
Assignments, Flexible		3-57, A-56			
Patterns		1_24			
Relay Tracking		3-23			
Ringing Tones, Personal		3-23, 3-65			
Types		3-22			
Delayed Times		3-59			
Delayed/Direct		3-58			
Night Transfer		3-58			
Ringing Line Preference	3-67, A-44, A-58				
Ring-No-Answer Forwarding Of Transferred Calls	A-13				
S					
Save Button		3-84			
Assigning For Caller ID		3-167			
Saved Number Redial	A-54, A-58				
Scout 900MX Digital Wireless Telephone		A-58			
Screened Call Transfer		A-14			
Seeking Repair Assistance		1-25			
Self Diagnostics		A-59			
Serial Data Port					
Configuring COM 2 For Caller ID		3-166			
Connecting Data Devices To The System		2-34			
Setting The Data Parameters		3-153			
Service Observing	3-71, A-59				
Setting The Audible First Ring Feature		3-166			
Setting The Caller ID Distribution		3-167			
Setting The Data Parameters		3-153			
Signaling, Tone or Voice		3-28			
SMDA		A-11			
Department Numbers		3-139			
Printout		3-140			
Records Deleted By The Attendant		3-143			
Reporting Through VDT Programming and					
Per-Station SMDA		A-11			
Station Assignment		3-139			
SMDA/SMDR		3-138			
SMDR		A-11			
Printout		3-142			
Software					
Disks		2-51			
Key		2-50			
Loading		2-52			
Loading And Up-Grading The System		2-50			
SOHVA Features	A-64, 3-67				
Speakerphone Support		A-59			
Specialized Route Access Configuration Records		4-33			

Specialized Route Access 3-130, A-59

Specifications, Understanding The General 1-19

Speed Dial 3-26

Square/Non-Square Configuration A-62

SRA 3-130, A-59

- Enable 3-130
- Enable Office And Area Code Tables 3-131
- Enable Special Area Code Tables 3-133
- Overflow Line Group 3-136
- Insert Digits For 3-135
- Wait Time 3-137

Station

- Button Mapping 3-77
- Configuration Records 4-13
- Connections 2_16, 2_19, 2_20, 2_21
- Controls and Indicators 1-16
- Disable 3-72
- Describing 1_10
- Features 3-45
- Messaging A-46, A-64
- Monitoring With DSS Call Pickup 3-24, A-63
- Name 3-72
- Numbering 3-60
- Park A-30
- Ports For Direct Department Calling 3-96
- Port Reassignment 3-74
- Relocation 2_17
- Speed Dial A-6, A-63
- SMDA Reporting 3-138
- SMDA Record 4-32
- SMDR A-11
- Testing 2-49

Subdued Off-Hook Voice Announce (SOHVA) A-64

- Groups A-65
- Features 3-67
- Originate Button A-64

Subdued Ringing A-57, A-66

Summarizing The Hardware 1-7

Supporting

- Caller Identification Service 2-76
- DigiTech Telephones 3-8
- DVA Operation 2-82
- Tracker Paging System 2-80

System Alarm

- Report Stations 3-75
- Reporting 3-25
- Reports A-66

System Clock 3-26

System Configuration Records 4-3

System Features Programming 3-16

System Programming, Understanding 3-17

System Ringing Patterns 1-24

System Software, Loading And Up-Grading The 2-50

System Speed Dial 3-26, A-6, A-66

System Status Indicator, Checking The 2-49

System Timing 3-30

T

Tandem Attendant 3-28, A-67

TAP (Flash/Recall) A-67

Tenant Service A-63, A-67

Testing The Stations 2-49

The Industry-Standard Telephone Interface 3-92

Time And Answer Time 3-128

Timed Hold Recall 3-33, A-37, A-67

Toll Restriction A-68

- Assign Override (TRO) Code 3-149
- Assignment Records 4-41

Toll Restriction Table

- Configuration Records 4-37
- Entries 3-146

Toll Restriction Tables 3-144

- Assign Entries 3-145
- Assign To Lines 3-147
- Assign To Stations 3-147
- Assign To Stations For Night Transfer 3-148
- Assign To System Speed Dial Calls 3-148
- Line Assignments Record 4-40

Toll Restriction Override A-69

Tone Dialing 3-42

Tone First Intercom Signalling 3-53

Tone Or Voice Signaling 3-28, A-41, A-69

Tools And Hardware 2-5

Tracker Pagers For Stations, Enabling The 3-153

Tracker Paging System 1-6, 3-151, A-70

- Enabling 3-152
- Preparing 3-152
- Records 4-44
- Support 2-80
- Using For Message Notification 3-112
- Using With VVP 3-111

Transfer/Conference Button A-70

Transferring Callers To Voice Mail 3-109, 3-112

Transferring Calls A-70

U

Unanswered Call Transfer

- Recall Time 3-34, A-15, A-7
- Recall Time For Direct Department Calling 3-97

Understanding System Programming 3-7

Understanding The General Specifications 1-19

Underwriters Laboratories Installation Notice 2-5

Unscreened Call Transfer A-15, A-71

Unsupervised Conferencing A-18

User Information, Locating 1-3

Using A Line Port As An		Versatile Voice Processing	3-111
External Paging Interface	2-33	Connecting	2-86
Using A Telephone To Program The System	3-7	Using Tracker Paging System With	3-111
Using A VDT To Program The System	3-11	Visual Ring Indication	3-24
Using Block Programming	3-11	Visual Voice Mail Support	3-113, A-71
Using Programming Overlays	3-11	Voice Announce Block Button	3-85
Using Related Publications	1-3	Voice Announce Blocking	3-76, A-41, A-72
Using Specialized Route Access		Voice Mail Interface	3-104
For Simplified Toll Restriction	A-62	Configuration Records	4-24
Using The Add-On Expansion Module	2-41	Voice Mail	
Using The Auxiliary Equipment Interface	2-29	Automatic Transfer	3-108
Using The External Paging Interface	2-32	Line ID	3-108, A-73
Using The JM008 Module	2-44	Pause	3-110, A-73
Using The JM408 Module	2-41	Port	3-105
Using The Music Interface	2-40	Support	A-72
Using This Manual	1-2	Transfer On Busy	3-109, A-73
Using Tracker For Message Notification	3-112	Transferring Callers To	3-109, 3-112
Using Tracker Paging System With Versatile Voice		Voltage Checking	2-48
Processing	3-111	Volume Control	A-73
<u>V</u>		VVP	3-111
VDT Connection	2-38	<u>W</u>	
Verified Account Code Entry	3-91	Wall Mounting The Telephone Stations	2-23
		<u>Z</u>	
		Zone Call Band Tables (Long Distance Calls)	3-123
		Zone Page/All-Call Button	3-85
		Zone Paging (Via Station Speakers)	A-74
		Zone Paging	3-22, A-49

Limited Warranty

The initial hardware and software of all Comdial Corporation (“Comdial”) products accompanying this installation manual shall be referred to collectively herein as the “Product”. Non-Comdial products are warranted solely by the manufacturer in accordance with the manufacturer’s warranty, and are sold by Comdial “as is”. Comdial warrants, only to its purchaser and its authorized dealers, that, under normal operating conditions, (a) the Product hardware (except for fuses, lamps and other consumables) and the medium on which the Product software is contained will be free from defects in material and workmanship, and (b) the Product software will perform substantially in accordance with the specifications set out in the user guide accompanying the Product which is prepared by Comdial, in each case for the period specifically stated in the warranty accompanying the Product, measured from the manufacturing date stamped on the Product hardware or software, as the case may be, provided however, development products, i.e., products which have not yet been approved by Comdial for production, are sold pursuant to Comdial’s field trial agreement and are warranted as set out therein. Comdial’s sole obligation under this warranty or under any other legal obligation with respect to the Product is to repair or replace, at its option, the Product at its Charlottesville, Virginia, headquarters, free of charge, if the Product is deemed defective by Comdial during the warranty period, with refurbished or new equipment or parts, at Comdial’s option, when the Product is returned to Comdial, freight or postage prepaid, during the warranty period, provided however, if Comdial is not able, using reasonable efforts, to cure or correct a defect, Comdial’s sole obligation shall then be to refund (or cause to be refunded) an equitable portion of the price Comdial was paid for the Product. This warranty does not apply if, in the sole judgment of Comdial, the Product, or any part(s) or component(s) thereof, have been improperly installed or installed or used in combination or in assembly with hardware or software not supplied by Comdial and which are not compatible with the Product or which are of inferior quality, design or performance, or the Product, or any part(s) or component(s) thereof, have been improperly handled, misused, abused, altered, tampered with, accidentally damaged, or damaged or malfunction or fail to function as a result of causes beyond Comdial’s reasonable control, including acts of God such as fire, flood, water, or lightning or other incidence of excessive or insufficient voltage or failure to follow instructions. Repair, wiring, or alteration of the Product other than as specifically authorized by Comdial or its authorized repair agent is prohibited and will void this warranty. This warranty does not cover costs associated with installation, removal, or reinstallation of the Product. Comdial does not warrant that the Product is compatible with all telephone or switching systems or that the Product is invulnerable or immune from unauthorized or fraudulent use, or unaccounted for access to the Product. THIS WARRANTY IS EXCLUSIVE, BEING IN LIEU OF ALL OTHER WARRANTIES, EXPRESS OR IMPLIED, INCLUDING, BUT NOT LIMITED TO, ANY IMPLIED WARRANTY OF MERCHANTABILITY OR FITNESS FOR A PARTICULAR PURPOSE.

Limitation Of Liability

WITHOUT EXPANDING UPON THE FOREGOING WARRANTY, THE MAXIMUM LIABILITY OF COMDIAL UNDER ANY WARRANTY, STATUTORY, EXPRESS OR IMPLIED, IS LIMITED TO THE PURCHASE PRICE OF THE PRODUCT. COMDIAL SHALL HAVE NO RESPONSIBILITY FOR DAMAGE TO PROPERTY OR ANY OTHER LOSS OR INJURY, INCLUDING CONSEQUENTIAL, INCIDENTAL, OR INDIRECT DAMAGES, SUCH AS LOSS OF PROFITS OR LOSS OF BUSINESS INFORMATION, DAMAGES DUE TO BUSINESS INTERRUPTION OR ANY OTHER PECUNIARY LOSS, EVEN IF COMDIAL HAS BEEN ADVISED OF THE POSSIBILITY OF SUCH DAMAGES, OR PUNITIVE DAMAGES, RESULTING FROM THE PURCHASE, POSSESSION, INSTALLATION, OPERATION, REPAIR, USE OF OF OR INABILITY TO USE, THE PRODUCT, OR THE UNAUTHORIZED OR THE FRAUDULENT USE OF, OR UNACCOUNTED FOR ACCESS TO, THE PRODUCT, ALL SUCH CLAIMS BEING HEREBY EXPRESSLY WAIVED. THE PURCHASER’S EXCLUSIVE WARRANTY AND REMEDY SHALL BE ONLY AS STATED HEREIN.

This warranty gives you specific legal rights and you may also have other rights which may vary from state to state. Some states do not allow limitations on how long an implied warranty lasts or the exclusion or limitation of incidental or consequential damages, so the above limitations may not apply to you. If the Magnuson Moss Act should be held to apply to the sale of the Product by a court of competent jurisdiction, the implied warranty of fitness for a particular purpose shall extend for one year from the date of manufacture. No Comdial dealer nor any other person or entity other than Comdial may extend or modify this warranty, and no such modification or extension shall be effective unless it is in writing.

This manual has been developed by Comdial Corporation (the “Company”) and is intended for the use of its customers and service personnel. The information in this manual is subject to change without notice. While every effort has been made to eliminate errors, the Company disclaims liability for any difficulties arising for the interpretation of the information contained herein.

The information contained herein does not purport to cover all details or variations in equipment nor to provide for every possible contingency to be met in connection with installation, operation, or maintenance. Should further information be desired, or should particular problems arise which are not covered sufficiently for the purchaser’s purposes contact, Comdial, Inside Sales Department, P.O. Box 7266, Charlottesville, Virginia 22906.



TECHNICAL ADVISORY BULLETIN

Date: February 1997

Issue: TAB001-DSU II

Software Enhancement 3A For The DSU II Digital Telephone System

This TAB discusses software release 3A for the DSU II digital telephone system. Release 3A includes the following new features:

- **Call Forward Outside System (CFOS)**
TAB pages 7, 9, 15, 17, 23, 31
- **DCD Enhancements:** —Ring Longest Idle
—Ring All On Transferred Line
TAB pages 11, 21, 25
- **SRA Enhancements:** —Speed Dialing with SRA
—Alternate Line Groups
TAB pages 13, 19, 27
- **2 Additional data ports to support Voice Mail and Tracker on DSU II 816 and 1632**
TAB pages 3, 5, 6, 29

When upgrading software, observe the following guidelines:

1. Save current COS database to disk.
2. Install the new software.
3. Master clear the system.
4. Restore the database.
5. Make additional programming if desired.

The information in this TAB is in the form of pages that you can insert in the following manual:

- IMI66-132, System Hardware And Software Instructions For The DSU II Digital Telephone System.

The features in this TAB are presented in the order they would appear in the manual; they are not grouped together. Refer to the list above for a list of features and their pages.

Printed in U.S.A.

This manual has been developed by Comdial Corporation (the "Company") and is intended for the use of its customers and service personnel. The information in this manual is subject to change without notice. While every effort has been made to eliminate errors, the Company disclaims liability for any difficulties arising from the interpretation of the information contained herein.

The information contained herein does not purport to cover all details or variations in equipment nor to provide for every possible contingency to be met in connection with installation, operation, or maintenance. Should further information be desired, or should particular problems arise which are not covered sufficiently for the purchaser's purposes contact, Comdial, Inside Sales Department, P.O. Box 7266, Charlottesville, Virginia 22906.

2.12.1 Making Modular Jack Data Connections

Modular jack connections are wiring connections from a station to a modular (wall) jack.

The system provides two serial data ports on the J0408:

- Connect a video display terminal (VDT), Tracker, or VoiceMail to COM 1.
- Connect a serial data printer or Caller ID to COM 2.

The system provides four serial data ports on the J0816 and J1632:

- Connect a video display terminal (VDT) to COM 1.
- Connect a serial data printer or Caller ID to COM 2.
- Connect VoiceMail to COM 3.
- Connect Tracker to COM4.

NOTE: The distance between a data device and the common equipment can be up to 500 feet in a quiet electrical environment. Some sites may require shielded cable for long runs. For longer distances, you must install limited distance modems to relay the data communications between the common equipment and a data device.

When preparing a cable for connection to a data device, refer to the manufacturer's manual for the equipment being interfaced and make the following wiring connections:

- Wire the common equipment RD (data from device to common equipment) connection to the device TD (transmit data) connection.
- Wire the common equipment TD (data to device from common equipment) connection to the device RD (receive data) connection.
- Wire the common equipment SG (signal ground) connection to the device SG (signal ground) connection.
- If required for proper operation, wire the common equipment CTS (clear-to-send status from device to common equipment) connection to the device RTS (request-to-send) connection.

NOTE: The common equipment requires a positive voltage, with respect to signal ground, in order to send data.

2.18.5 Supporting The Tracker Paging System

The optional Tracker paging system allows you to send alpha/numeric or numeric-only messages to the Tracker Pagers assigned to a station extension number. The type of message that the system delivers is dependent on the Tracker Pager model being used. Tracker's paging option requires only one connection to the digital telephone system; however, you will need to take several programming steps to make it operational.

- If you use station 10 programming to configure the system, install the Tracker base station to the common equipment cabinet's communications serial data port. Then, after you have completed the installation, take the programming action detailed in Chapter 3, Section 3.17.
- If you use a video display terminal (VDT) to configure the system, you must connect it to the COM1 serial data port and ***you must take programming action to enable the Tracker Pager option and enable Tracker Pagers at stations before you actually install the Tracker Pager system.*** (This is necessary since the Tracker Pager system also uses the COM1 serial data port and there would be no way to program with a VDT if the Tracker Pager system was already installed.)

To connect Tracker to a J0408,

1. When you finish programming, press CONTROL C for the main menu, and log out from the programming mode.
2. Disconnect the VDT from COM 1. As soon as you do this, the system begins polling COM1 every two seconds and waiting for a response from a Tracker base station.
3. Connect the Tracker Pager system to COM1. As soon as you connect the Tracker base station to COM1, the DSU II system recognizes the Tracker base station's presence and makes Tracker Pager features available to system users.

NOTE: While the Tracker base station remains connected, the system continues to poll the port every 10 seconds to verify its presence. This means that if you disconnect the Tracker base station to reconnect the VDT, you may have to wait as long as 10 seconds for the system to notice that you have replaced the Tracker base station with a VDT.

To connect Tracker to a J0816 or a J1632,

1. Connect the Tracker Pager system to COM4. As soon as you connect the Tracker base station to COM4, the DSU II system recognizes the Tracker base station's presence and makes Tracker Pager features available to system users.

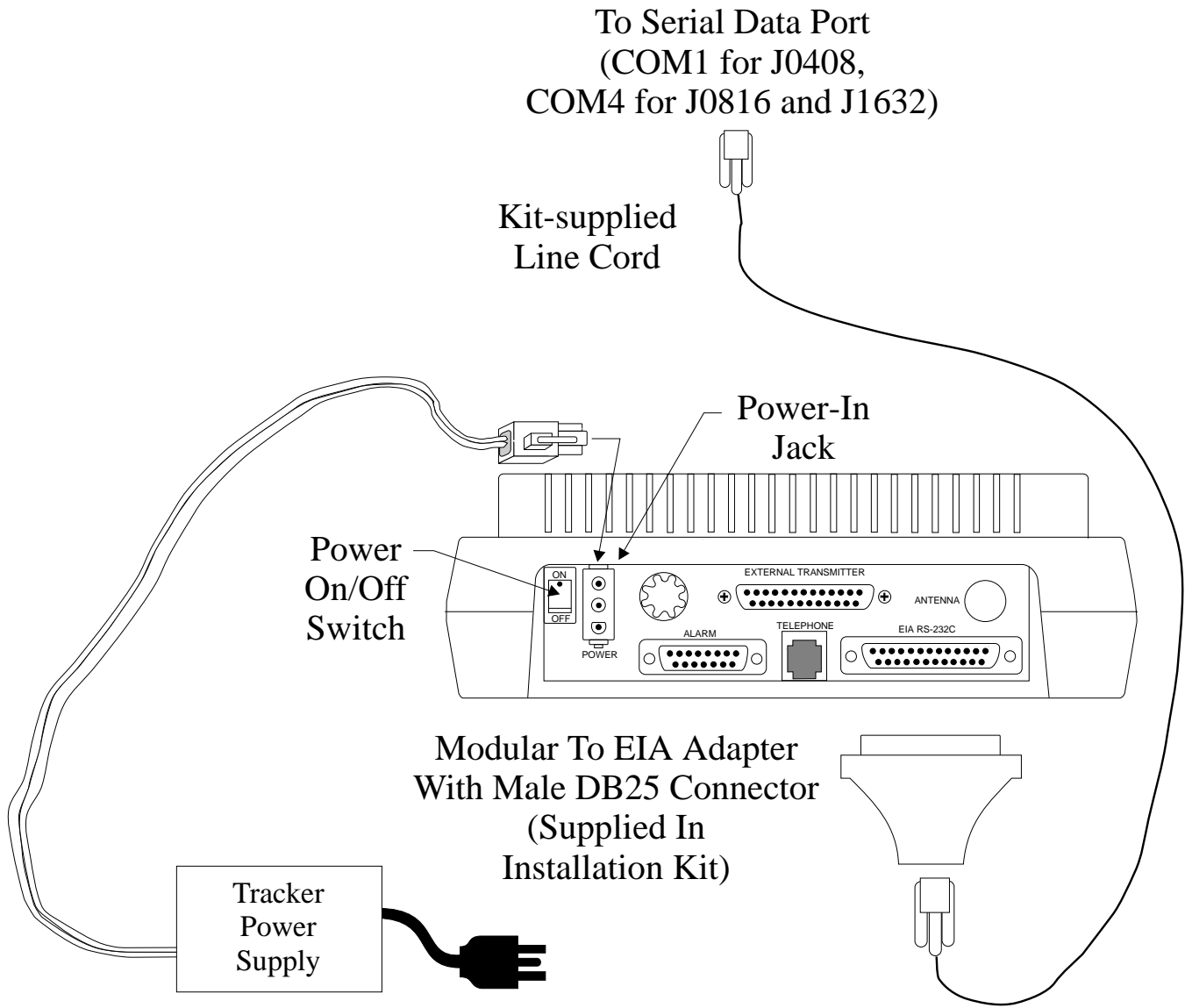

dsu262.cdr

3.4.15 Call Forward Outside System

Description: Call Forward Outside System (CFOS) gives station users the ability to forward line calls to a location outside the DSU II Digital Telephone System. Be sure to set the abandon hold release time on all lines that you use for CFOS to match the C.O. abandon hold release time.

- To Program:**
1. Press **ITCM**, dial ***#746***. *“CONFIG MODE”*
 2. Dial **17** for system features. *“SYSTEM FEATURES”*
 3. Dial **14** for system CFOS. *“CFOS XXXXXXXX”*
 4. Press **A1** key to toggle between enable and disabled (LED On = Enable)
—OR—
dial **1** to Enable *“CFOS ENABLED”*
dial **2** to Disable. *“CFOS DISABLED”*
 5. Dial ***** for system features.
 6. Dial ****** for configuration mode.

Call Forward Outside System For Station Ports

Description: Use this procedure to enable or disable the CFOS (Call Forward Outside System) feature for the station ports you select.

- To Program:**
1. Press **ITCM**, dial ***#746***. *“CONFIG. MODE”*
 2. Dial **53** for station features. *“STATION FEATURES”*
 3. Dial **42** for station CFOS. *“CFOS STATIONS”*
 4. Select station ports for programming to toggle status
Station 10-57 = Dial **10-57**
—OR—
Press DSS keys **C10-C57** on DSS console to enable or disable (LED On = Enable).
 5. Dial ***** for station features.
 6. Dial ****** for configuration mode.

3.11.6 DCD Type Ring All Stations

Description: Enabling the system-wide ring all DCD feature causes a transferred call to ring at all idle stations in a department until it is answered. The answering station gets the call while the remaining stations retain their original status.

Default = disabled

To Program:

1. Press **ITCM**, dial ***#746***. *“CONFIG MODE”*
2. Dial **17** for system features. *“SYSTEM FEATURES”*
3. Dial **15** for Ring All. *“RING ALL XXX”*
4. Press **A1** key to toggle between enable and disable (LED On = Enable)
—OR—
dial **1** to Enable *“RING ALL ON”*
dial **2** to Disable. *“RING ALL OFF”*
5. Dial ***** for system features.
—OR—
Dial ****** for configuration mode.

3.11.7 DCD Type Longest Idle Distribution

Description: Enabling the system-wide longest idle DCD feature causes any call to a department to ring at the station that has been idle for the longest period of time. If the station is in DND mode, the call rings the next longest-idle station.

Default = disabled

To Program:

1. Press **ITCM**, dial ***#746***. *“CONFIG MODE”*
2. Dial **17** for system features. *“SYSTEM FEATURES”*
3. Dial **16** for DCD longest idle. *“LONGEST IDLE XXX”*
4. Press **A1** key to toggle between enable and disable (LED On = Enable).
—OR—
Dial **1** to Enable *“LONGEST IDLE ON”*
Dial **2** to Disable. *“LONGEST IDLE OFF”*
5. Dial ***** for system features.
—OR—
Dial ****** for configuration mode.

3.17.7 SRA Alternate Line Groups

Description: The alternate line groups feature enables the system to try an alternate line group if no lines are available in the original group. Each line group can have one alternate line group. No alternate line groups are assigned by default. SRA alternate line groups are included in database printouts.

If digit insertion is programmed, it will be done for the actual line group the call is being routed over.

To Program:

1. Enter **I*746*** for Main menu.
2. Enter **1** for system COS menu.
3. Enter **16** for Specialized Route Access menu.
4. Enter **11** for SRA Alternate line group.
5. Enter **1-4** for the line group number.
6. Enter **1-4** the alternate line group number.

Station Monitoring		
Visual Ring Indication	Enable	Disable
Audible Ring Indication Stations (10-57)		
<i>Default = Visual indication disabled, no audible indication assigned.</i>		

Tandem Attendant	
Enable	Disable
<i>Default = Disable</i>	

Tone or Voice Signaling	
Voice	Tone
<i>Default = Tone</i>	

SOHVA Tone Bursts	1	2	3	4	5	6
<i>Default = 6</i>						

PA Options				
Direct Ringing Lines (1-24)				
Delayed Ringing Lines (1-24)				
Night Ringing Lines (1-24)				
Zone Paging Enabled	Zone 1	Zone 2	Zone 3	All-Call
Relay Port Relay Tracking	Station 17		Paging Port	
PA Port Signal Tone	Intercom		DTMF	
<i>Default = No ringing lines, all-call paging, station 17 ringing, and intercom tone.</i>				

Allow Ringer Off Option	
Enabled	Disabled
<i>Default = Enabled</i>	

Call Forward Outside System	
Enabled	Disabled
<i>Default = Disabled</i>	

4.4 Recording The Station Configurations

Use this sheet as an individual station record or as a record for a block of similarly programmed stations. Make copies of this blank sheet as needed to meet system capacity.

Feature	Choice	Default	Enter Station Port Numbers							
Access Denied	Lines 1-24	None								
All-Call and Zone Paging Receive	All/1-3	All								
Originate	All/1-3	All								
Audible Monitoring	None/Dir/Delay	None								
Automatic Hold	Yes/No	No								
Automatic Hold - Intercom	Yes/No	No								
Automatic Privacy Privacy Release	None/1-24	None								
Call Forward On Ring No-Answer	No/1-9 Rings	No								
Call Forward On Busy	Yes/No	No								
Call Forward Outside System	Yes/No	No								
Call Origination Denied	No/1-24	No								
Central Message Desk	Yes/No	No								
Data Security Port	Yes/No	No								
Do Not Disturb Override	Yes/No	No								
Dual Console Feature	No/10-57	No								
Executive Override	Yes/No	No								
Flexible Ringing	Direct	1-24	All (Sta. 10, 17)							
	Delayed	1-24	None							
Night Transfer (of ringing)	1-24	All (Sta. 10, 17)								
Flexible Station Numbering	10-7999	Ext = Port								
Group Call Pickup	1-4	1								
Headset Interface	Yes/No	No								
Idle Line Preference	No/ 1-24	No								
Intercom Hunt Group	10-57	None								
Personal Ring Tones	1-6	1								
Prime	Line	1-24	None							
	Group	1-4	None							
	Intercom	Itcm.	None							
Message Waiting Originate	Yes/No	Yes								
Ringling Line Preference	Yes/No	No								
SOHVA Disable	Yes/No	No								
SOHVA Groups	None/1-8	None								
Service Observing	Yes/No	No								
Station Disable	Yes/No	No								
Station To Station Port Reassignment	10/57	Sta = Port								
System Alarm Report	Yes/No	No								
Voice Announce Blocking	Yes/No	No								

Block Programming					
Model Station Port					
First Station Port					
Last Station Port					

Overflow Line Group	
<i>Default = None</i>	

Line Group	Alternate Line Group
1	
2	
3	
4	
<i>Default = None</i>	

SRA Wait Time	2 seconds	3 seconds	4 seconds
<i>Default = 4 seconds</i>			

Line Group	Insert Digits							
	1	2	3	4	5	6	7	8
1								
2								
3								
4								
<i>Default = None</i>								

4.7 Direct Department Calling Records

Enable/Disable DCD Type Ring All Stations	
Enabled	Disabled

Enable/Disable DCD Type Longest Idle Distribution	
Enabled	Disabled

Department 1	
Access Code 10-7999	
Line Ports 1-24	
Station Ports 10-57	

Department 2	
Access Code 10-7999	
Line Ports 1-24	
Station Ports 10-57	

Department 3	
Access Code 10-7999	
Line Ports 1-24	
Station Ports 10-57	

Department 3	
Access Code 10-7999	
Line Ports 1-24	
Station Ports 10-57	

Default = No access code assigned, no line ports assigned, and no stations assigned.

Call Forward Outside System

The Call Forward Outside System (CFOS) feature allows the system to forward incoming or transferred line calls to telephone numbers outside the system. The CFOS feature forwards calls over any available outbound lines or line groups. Since CFOS involves outbound calls, those calls are subject to all line access, toll restriction, and specialized route access restrictions normally imposed on the users. Any calls that CFOS can not service (no outbound line available, toll restricted, and so forth), ring the system as normal calls. The CFOS feature is useful for after-hours forwarding of business calls to alternate sites such as a home or cellular telephone. To help system managers keep account of CFOS activity, the system marks CFOS calls with an *F* in the SMDA records printout.

Users activate or deactivate CFOS by dialing a feature code or pressing a preprogrammed button. Once users activate CFOS, they select the outbound line or line group in any of the normal line selections methods available to them. They also designate the forward destination by dialing the number or pressing a speed dial button. (If users do not make a line and destination choice, the system uses the most recently used selections.) Once a user activates CFOS, it remains active and neither system resets nor power outages will deactivate it. After activation, incoming or transferred calls to an idle CFOS-enabled station forward outside the system to the CFOS destination over the selected outbound line or line group.

CFOS remains in effect in the event of loss of power or a system reset. Lines used for CFOS must have their abandon hold release time set to match the central office. Because CFOS is a powerful feature with the potential for abuse, several safety features have been added. Programming safeguards include the ability to enable the feature only on selected stations and master control ability for enabling and disabling the feature system-wide. Ultimate responsibility for system integrity, however, lies with the system administrator.

Comdial has taken reasonable steps in the design of all product features, including CFOS, which protect against unauthorized or fraudulent access to, or use of, a system, or which protect against unauthorized, fraudulent or unaccounted-for access to, or use of, long distance lines. However, no system is entirely invulnerable or immune from unauthorized or fraudulent access or use, or unaccounted-for access or use, and therefore Comdial disclaims any and all liability, and makes no warranty, express or implied, relating to unauthorized or fraudulent access or use, or unaccounted-for access or use.

NOTES: (1) CFOS will not work unless the abandon hold release time on all lines used for CFOS matches the C.O. abandon hold release time.

(2) Calls forwarded through CFOS may experience lower audio levels due to the normal line resistance of C.O. lines. Low audio level is usually only noticeable on long line loops. If signal loss is a problem at a particular site, the installer may need to add a line amplifier (repeater) in the lines.

Departmental Call Distribution

Software 3A contains the following enhancements to the DCD feature:

Ring All On Transferred Line Call

By enabling the system-wide ring all DCD feature, a transferred line call ringing to a department will ring all idle stations in the department until the call is answered. The answering station gets the call and remaining stations retain their original status.

The Ring All On Transferred Line Call feature is disabled by default.

Ring Longest Idle Station

The Ring Longest Idle Station feature causes a direct-ringing line call, a transferred line call, or an intercom call to ring at the longest-idle station in a department. If the longest-idle station is in Do Not Disturb or Ring No Answer mode, the system routes the call to the next available station in the group.

Specialized Route Access Enhancements

Software 3A contains the following enhancements to the SRA feature:

- The system routes speed dial calls through SRA similarly to the way manually dialed calls are routed. The speed dial location must not have a preselect and must contain at least one digit. No programming is required to enable this feature.
- The system now routes calls through an alternate line group if no lines are available in the original line group. If no lines are available in the alternate line group, the system searches the overflow line group for an available line. Each line group has one alternate line group; the system will not assign alternate line groups by default.

V

Visual Voice Mail

Visual Voice Mail (VVM) support provides proprietary, two-line display LCD speakerphone stations with visual messages and interactive buttons. This message and button functionality enhances the stations with visual messages and interactive buttons. This message and button functionality enhances the station's use with Comdial Versatile Voice Processing (VVP) voice mail equipment. To implement VVM support, the system programmer must enable it with class of service programming action.

NOTE: On the J0408, VVM requires the same serial data connection to the common equipment cabinet as does the Tracker Paging System, making the Tracker Paging System unavailable while VVM is operational.

The J0816 and J1632 use separate serial data connection ports for Tracker and VVM, enabling both to run simultaneously.

When enabled, VVM causes the speakerphone to display a **VMAIL** button that users press to call the voice mail system. After they press this button, the system prompts them to enter a password. (This password is one the programmer assigns to the stations.) Once users enter the password, the speakerphone's display shows the VVP's main menu. From there, users can select the operation they wish to pursue.

When there is a message waiting, the display shows the message quantity in place of the **VMAIL** button (for example, **5 MSG**). Users press the **MSG** button to play the stored messages. The system prompts the user to enter a password (if programmed to require one) before it plays the new messages.

Activating CFOS From Individual Stations

***NOTE:** This section is formatted like a typical user's guide so that, if you wish, you may cut it out and insert it in the user's guides you distribute to your customers.*

The Call Forward Outside System (CFOS) feature gives station users the ability to forward line calls to a remote location outside the system. CFOS remains in effect in the event of a loss of power or a system reset.

- **To activate the CFOS feature,**
 1. Press **ITCM *07**.
 2. Press the speed dial button programmed with the target number,
—OR—
Press a line button,
—OR—
Dial **0** for the Prime line or last used line,
—OR—
Dial **1-4** Line Group number.
 3. Dial desired digits **0-9** (max 16 digits)
 4. Press **HOLD** for Pause or press **TAP** for Flash.
 5. Press **SPEAKER** to end.

- **To deactivate CFOS feature,**
 1. Press **INTERCOM # 07**.



TECHNICAL ADVISORY BULLETIN

Date: September 1997

Issue: TAB002–DSU II

Software Enhancements For The Digital Telephone System

This bulletin discusses the following software enhancements and feature additions to the digital telephone system that are available with software release 4A and later:

- New *Impact SCS* Telephone support

When upgrading software, observe the following guidelines:

NOTE: It is always a good practice to save the data base for backup purposes before you up-grade the system software revision.

The following pages describe the *Impact SCS* telephone support. Note that TAB002–DSU II presents this information as separate pages that you can insert in your system manual (IMI66–132). If you do this, the information will be available for your future reference and use.

1.6.5 Impact Telephone New Model Support

Digital telephone systems support a group of newly designed *Impact* telephone models. The model numbers of these telephones are listed below.

8324S	— 24 Line Half-Duplex LCD Speakerphone
8324F	— 24 Line Full-Duplex LCD Speakerphone
8312S	— 12 Line Half-Duplex LCD Speakerphone
8212S	— 12 Line Half-Duplex Speakerphone
8212N	— Multiline Proprietary Telephone
8201N	— Single Line Proprietary Telephone
IB48X	— 48-Button DSS/BLF Console
IB24X	— 24-Button DSS/BLF Console
IMIST	— IST Module

Button Mapping The New Impact Telephone Models

On Model 8324F, 8324S, 8212S, and 8312S telephones, you can move the intercom button from its defaulted and marked location at the lower rightmost button position to any programmable button location. If you map a new location for the intercom button, be sure to clear the previous assigned location. If you delete the intercom button from a telephone, the system will restore it at the default location the next time that power turns off and back on at the telephone. Use the following button mapping program procedure to map the new intercom button location.

1. At the programming station, press the defaulted **INTERCOM** button and dial ***#746*** to enter the programming mode.
2. Dial **56**. “*BUTTON MAPPING*”
3. Dial **19**. “*ASSIGN ITCM* ”
4. Select button to be programmed
—Press **A1–A14, B1–B10**.
5. Select station ports (LED On = Selected)
—Station 10–57 = Dial **10–57** or dial **C10–C57**.
6. Dial ***** for further intercom button assignment, or dial ******* to return to the configuration mode.

*NOTE: To clear a button assignment while in the configuration mode, dial **5604**, press the button, dial #, select the station, and dial *******.*

7. End the programming session by pressing the **SPEAKER** button.

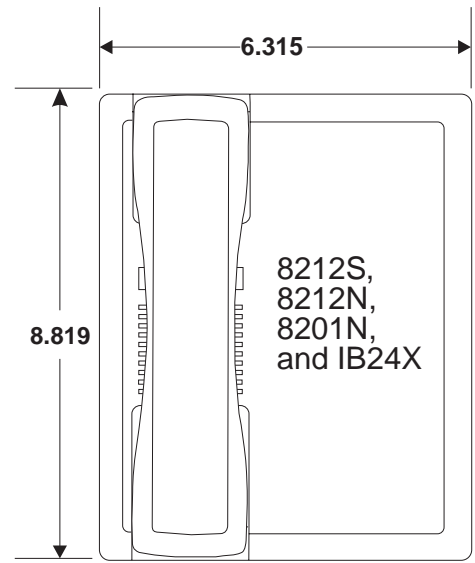
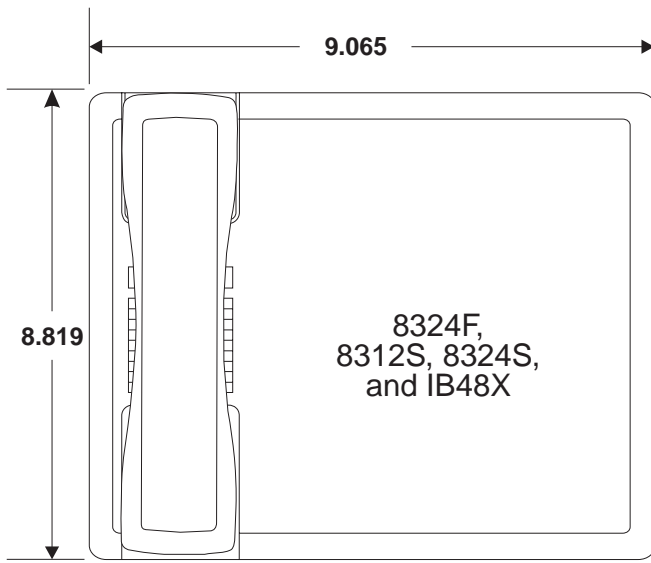

image_2.cdr

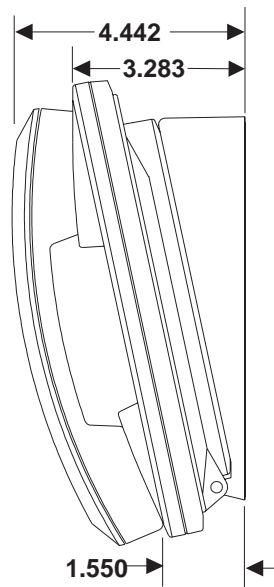

Viewing The New Impact Telephone Dimensions

Illustrating The New Impact Telephone Models

The following illustrations show the outline and dimensional views of the new *Impact* telephones.

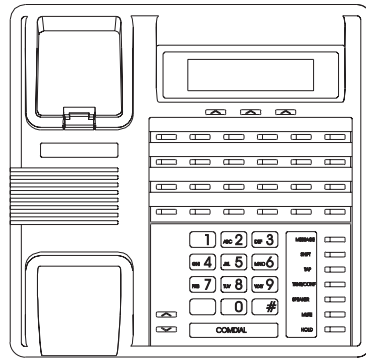

**8324F
8324S**

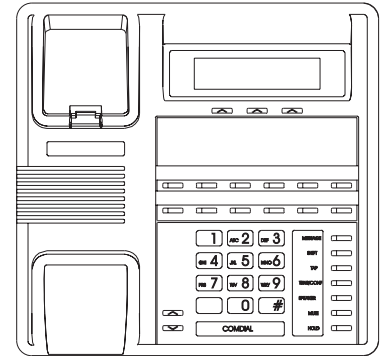

8312S

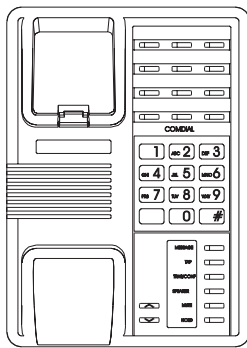

8212S

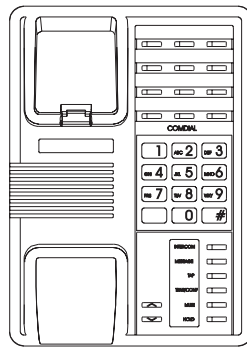

8212N

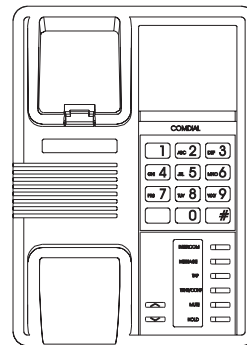

8201N

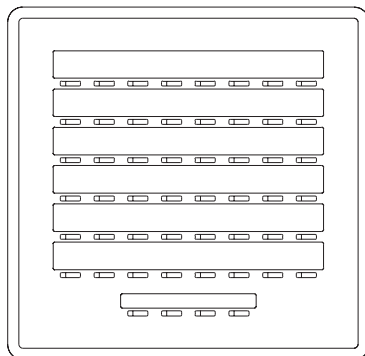

IB48X

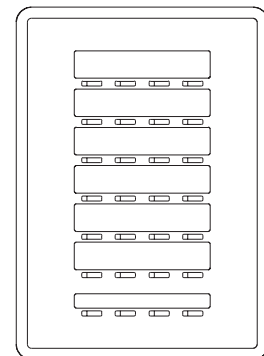

IB24X

image 1.c r

Viewing The New Impact Telephone Outlines

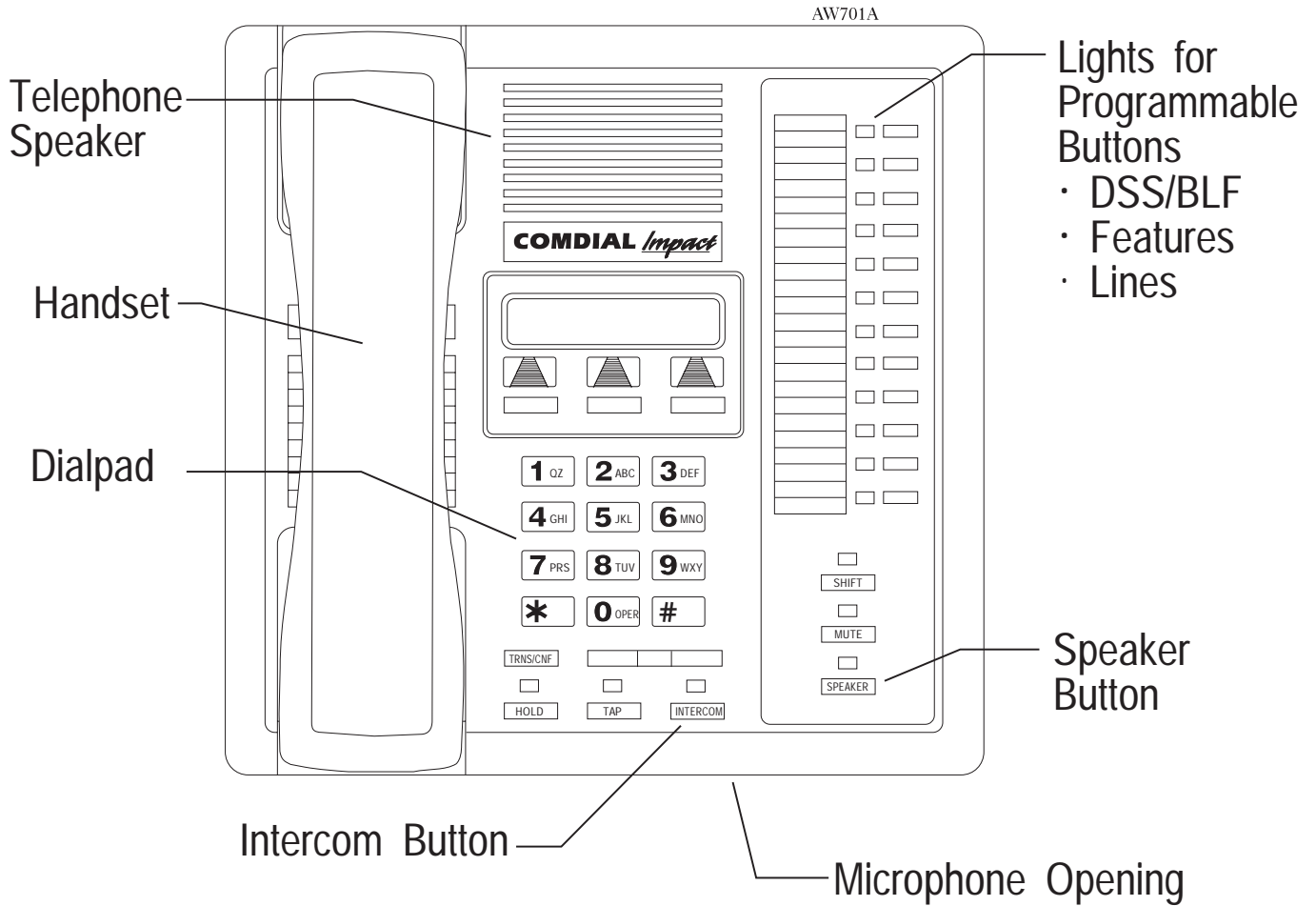

Typical Impact SCS Speakerphone Controls And Indicators

TECHNICAL ADVISORY BULLETIN

Date: May 1998

Issue: TAB003–DSU II

Software Release 5A For The Digital Telephone System

This TAB discusses DSU II software release 5A, which includes the following new features:

- Ringback on Transfer,
- Delay Ring in Night Mode,
- Quick Transfer,
- Secure Account Code Entry,
- Call Record Enhancement.

The operation and programming of these features is discussed in the next five sections of this document. The information is presented as separate pages that you can insert in your system manual (IMI66–132).

NOTE: Before you up-grade the system software, it is a good practice to save the database for backup purposes.

3.4.15 Ringback On Transfer

Description: With Ringback On Transfer enabled, when an outside call is transferred to another station, the system gives ringback to the outside caller instead of music on hold. This feature is disabled at default.

- To Program:**
1. Dial **17** for system features. *“SYSTEM FEATURES”*
 2. Dial **17** for ringback on transfer. *“RINGBACK XFER XXX”*
 3. Press **A1** to toggle between enabled and disabled (LED On = Enabled).
—OR—
Dial **1** to enable. *“RINGBACK XFER ON”*
Dial **2** to disable. *“RINGBACK XFR OFF”*
 4. Dial ***** for configuration mode.

To change setting, repeat procedure and make different selection.

Delay Ring In Night Mode

Description: This feature adds the option of programming delayed ringing in night mode (delayed ringing could previously only be assigned to day mode). This feature affects station ringing assignments as well as system PA port ringing. At default, this feature does not allow delayed ringing during night mode.

To Program: Ringing Assignment:

1. Dial **54** for station/line features *“STA/LINE CONFIG”*
2. Dial **3** for night direct ring. *“NITE DIRECT RING”*
—OR—
Dial **8** for night delay ring. *“NITE DELAY RING”*
3. Select line ports for delayed night ringing (LED On = Selected Ports).
—Line port 1–14 = Dial **01–14** or press **A1–A14**.
—Line port 15, 16 = Dial **15, 16** or press **B1, B2**.
—Line port 17–24 = Dial **17–24** or press **HOLD** then press **A1–A8**.
4. Dial **#** when all line ports are selected.
5. Select station ports (LED On = Feature Assigned)
—Station 10–57 = Dial **10–57** or press **C10–C57**.
6. Dial ***** when all station ports are selected.
—OR—
Dial ****** for next station/line feature.
—OR—
Dial ******* for configuration mode.

To change setting, repeat procedure and make different selection.

PA Port Ringing Type:

1. Dial **60** for PA Options. *“P.A. OPTIONS”*
2. Dial **3** for night direct ring. *“NITE DIRECT RING”*
—OR—
Dial **7** for night delay ring. *“NITE DELAY RING”*
3. Select line ports (LED On = Line selected):
—Line port 1–14 = Dial **01–14** or press **A1–A14**.
—Line port 15, 16 = Dial **15, 16** or press **B1, B2**.
—Line port 17–24 = Dial **17–24** or press **HOLD** then press **A1–A8**.
4. Dial ***** for next PA option.
—OR—
Dial ****** for configuration mode.

3.7.31 Quick Transfer

Description: The Quick Transfer feature allows users to transfer line calls without having to press the **TRANSFER/CONFERENCE** key. When this feature is enabled, users can transfer calls by pressing the appropriate DSS key (or **INTERCOM** + extension number) and then hanging up. This feature is disabled at default.

- To Program:**
1. Dial **53** for station features. *“STATION FEATURES”*
 2. Dial **43** for quick transfer. *“QUICK TRANSFER”*
 3. Select station ports (LED On = Selected):
—Station 10-57: Dial **10-57** or press **C10-C57**.
 4. Dial * for next station feature
—OR—
dial ** for configuration mode.

To change setting, repeat procedure and make different selection.

3.9.7 Secure Account Code Entry

Description: When system-wide account code entry is enabled, the system prompts users to enter an account code when they select an incoming or outgoing line. If the Secure Account Code entry feature is enabled, the digits will be displayed as “*” characters in the LCD during account code entry. At default, this feature is disabled.

The Secure Account Code entry status is shown with the toll restriction C.O.S. printout.

- To Program:**
1. Dial **75** for SMDA programming. *“SMDA PROGRAMMING”*
 2. Dial **18** for secure account code entry. *“SECURE ACC. XXX”*
 3. Press **A1** key to toggle between enable and disable (LED On = Enable).
—OR—
Dial **1** to Enable *“SECURE ACC. ON”*
Dial **2** to Disable *“SECURE ACC. OFF”*
 4. Dial ****** for configuration mode.

To change setting, repeat procedure and make different selection.

Call Recording

During a line call, the LCD works differently depending on whether or not you are using voice mail with serial integration:

- If you do not have serial voice mail, the LCD shows the **ARDL SAVE TIMER** options on line 2. The system replaces these options with a call timer after 60 seconds.
- If you do have serial voice mail, the system replaces the **SAVE** button with a **REC** button, and the LCD shows: **ARDL REC TIMER** on line 2. This remains on the LCD for the duration of the call. Pressing the **TIMER** button at any point during the call displays the call timer.

Whether or not you are using serial voice mail, if you have enabled call costing, the system replaces the **TIMER** button with a **COST** button.

TECHNICAL ADVISORY BULLETIN

Date: November 1998

Issue: TAB004–DSU II

Software Release 5B For The Digital Telephone System

This TAB discusses DSU II software release 5B, that includes the following new feature:

- Disconnect Notification

The disconnect notification feature allows the DSUII system to operate properly with CT Voice. By notifying the CT Voice system whenever the distant party disconnects, delays are prevented.

The operation and programming of this feature is discussed in the next section of this document. The information is presented as separate pages that you can insert in your system manual (IMI66–132).

NOTE: Before you up-grade the system software, it is a good practice to save the database for backup purposes.

This manual has been developed by Comdial Corporation (the "Company") and is intended for the use of its customers and service personnel. The information in this manual is subject to change without notice. While every effort has been made to eliminate errors, the Company disclaims liability for any difficulties arising from the interpretation of the information contained herein. The information contained herein does not purport to cover all details or variations in equipment or to provide for every possible contingency to be met in connection with installation, operation, or maintenance. Should further information be desired, or should particular problems arise which are not covered sufficiently for the purchaser's purposes, contact Comdial, Inside Sales Department, P.O. Box 7266, Charlottesville, Virginia 22906.

3.6.11 Disconnect Notification

Description: With the Disconnect Notification feature, the system sends a DTMF “A” digit to the IST station ports whenever the distant party (internal or external) hangs up. The system also sends a disconnect digit when an IST telephone signals a hookflash to retrieve a line from hold that has been dropped through abandon hold release. Installers must enable line disconnect supervision for this feature to function on outside calls. This feature is disabled at default. The purpose of this feature is to avoid delays that may occur on disconnects when the CT Voice application is being used.

- To Program:**
1. Press ITCM, dial *#746* “CONFIG MODE”
 2. Dial **53** for station features “STATION FEATURES”
 3. Dial **44** for disconnect notification ”DISCONNECT NOTIF”
 4. Select station ports (LED On = Feature Assigned):
Station 10 - 57: Dial **10 - 57**
—OR—
Press **C10 - C57**.
 5. Dial * for next station feature
—OR—
Dial ** for configuration mode.

4.4 Recording The Station Configurations

Use this sheet as an individual station record or as a record for a block of similarly programmed stations. You can make copies of this blank sheet as needed to meet the system capacity.

Feature	Choice	Default	Enter Station Port Numbers							
Access Denied	Lines 1–24	None								
All-Call and Zone Paging Receive	All/1–3	All								
Originate	All/1–3	All								
Audible Monitoring	None/Dir/Delay	None								
Automatic Hold	Yes/No	No								
Automatic Hold - Intercom	Yes/No	No								
Automatic Privacy Privacy Release	None/1–24	None								
Call Forward On Ring No-Answer	No/1–9 Rings	No								
Call Forward On Busy	Yes/No	No								
Call Origination Denied	No/1–24	No								
Central Message Desk	Yes/No	No								
Data Security Port	Yes/No	No								
Disconnect Notification	Yes/No	No								
Do Not Disturb Override	Yes/No	No								
Dual Console Feature	No/10–57	No								
Executive Override	Yes/No	No								
Flexible Ringing	Direct	1–24	All (Sta. 10, 17)							
	Delayed	1–24	None							
Night Transfer (of ringing)	1–24	All (Sta. 10, 17)								
Flexible Station Numbering	10–7999	Ext = Port								
Group Call Pickup	1–4	1								
Headset Interface	Yes/No	No								
Idle Line Preference	No/ 1–24	No								
Intercom Hunt Group	10–57	None								
Personal Ring Tones	1–6	1								
Prime	Line	1–24	None							
	Group	1–4	None							
	Intercom	Itcm.	None							
Message Waiting Originate	Yes/No	Yes								
Ring Line Preference	Yes/No	No								
SOHVA Disable	Yes/No	No								
SOHVA Groups	None/1–8	None								
Service Observing	Yes/No	No								
Station Disable	Yes/No	No								
Station To Station Port Reassignment	10/57	Sta = Port								
System Alarm Report	Yes/No	No								
Voice Announce Blocking	Yes/No	No								

Block Programming					
Model Station Port					
First Station Port					
Last Station Port					

Disconnect Notification

Use the disconnect notification feature to reduce delays resulting from disconnects. These delays occur when using the CT Voice application.

When you enable this feature, it causes the system to send a DTMF “A” digit to IST station ports whenever the distant party (internal or external) hangs up. The system also sends a disconnect digit when an IST telephone signals a hookflash to retrieve a line from hold that has been dropped through abandon hold release.

Installers must enable line disconnect supervision for this feature to function on outside calls. This feature is disabled at default.

During station class of service data printout, the disconnect notification status is included on the printout.